

# EUROPEAN JOURNAL OF STEM EDUCATION

Volume 4, Issue 1  
2019

**Editor-in-Chief**

**Hanno van Keulen**

Windesheim University of Applied Sciences (The Netherlands)

e-ISSN: 2468-4368

JOURNALS  
**lectito**

*This page intentionally left blank.*

## EDITORIAL BOARD



### Editor-in-Chief

**Hanno van Keulen**

Windesheim University of Applied Sciences (The Netherlands)  
[h.van.keulen@windesheimflevoland.nl](mailto:h.van.keulen@windesheimflevoland.nl)

### Editorial Board

**Amauri Bartoszeck**, Department of Physiology & Neuroscience and Emergent Science Education, University of Paraná (Brazil)

**Andreas Dress**, Faculty of Mathematics, University of Bielefeld (Germany)

**Antonio Quesada**, Department of Science Education, University of Jaén, (Spain)

**Azra Moeed**, Science Education, Faculty of Education, Victoria University of Wellington (New Zealand)

**Cassandra Wiener**, University of Sussex (UK)

**Cathy Bunting**, Faculty of Education, The University of Waikato, (New Zealand)

**Cristina Almeida Aguiar**, Department of Biology, Escola de Ciências, University of Minho (Portugal)

**Erin E. Peters-Burton**, Science Education and Educational Psychology, College of Education and Human Development, George Mason University (USA)

**Evangelia Mavrikaki**, Faculty of Primary Education, National and Kapodistrian University of Athens (Greece)

**Gilmor Keshet**, School of Education, The Hebrew University of Jerusalem (Israel)

**Ileana M. Greca**, Departamento de Didacticas Especificas, Universidad de Burgos, (Spain)

**Jogymol K. Alex**, Department of Mathematics and Science Education, Walter Sisulu University (South Africa)

**Jonas Hallström**, Linköping University (Sweden)

**Joseph Jabulane Dhlamini**, College of Education, University of South Africa (UNISA), (South Africa)

**Juliette Walma van der Molen**, Department of Teacher Development (ELAN) and Centre for Science Education and Talent Development, University of Twente (The Netherlands)

**Kieran McGeown**, St Mary's University College, Queen's University, Belfast (Northern Ireland)

**Laszlo Egyed**, The University of Kaposvar, (Hungary)

**Liz Lakin**, School of Social Sciences, University of Dundee (UK)

**Maartje Raijmakers**, Educational Sciences, Leiden University and Science Center NEMO Amsterdam (The Netherlands)

**Maria Eduarda Ferreira**, Polytechnic Institute of Guarda, (Portugal)

**Maria Evagorou**, Department of Education, University of Nicosia (Cyprus)

**Marc J. de Vries**, Science Education and Communication, Delft University of Technology (The Netherlands)

**Martin Bilek**, The University of Hradec Kralove, (Czech Republic)

**Mohd Salleh Abu**, Faculty of Education, Universiti Teknologi Malaysia, (Malaysia)

**Pavol Prokop**, Department of Biology, Faculty of Education, Trnava University, (Slovakia)

**Perry den Brok**, Chair of Education and Competence Studies, Wageningen University (The Netherlands)

**Remalyn Quinay Casem**, Don Mariano Marcos Memorial State University, (Philippines)

**Reuven Babai**, Department of Mathematics, Science and Technology Education, Tel Aviv University, (Israel)

**Rohaida Mohd. Saat**, Department of Mathematics and Science Education, University of Malaya (Malaysia)

**Ronald Keijzer**, University of Applied Sciences, iPabo, Amsterdam (The Netherlands)

**Scott R. Bartholomew**, Department of Technology Leadership & Innovation, Purdue University, West-Lafayette (USA)

*This page intentionally left blank.*

TABLE OF CONTENTS

Research Articles

- 1 **Influence of Teachers Preparedness on Performance of Pupils in Mathematics in Lower Primary Schools in Aberdares Region of Kenya**  
Loise Wangechi Kariuki, Johannes Njagi Njoka, Zachariah Kariuki Mbugua  
<https://doi.org/10.20897/ejsteme/3931>
- 2 **Developing a Module to Teach Thermodynamics in an Integrated Way to 16 Year Old Pupils**  
Leen Goovaerts, Mieke De Cock, Katrien Struyven, Wim Dehaene  
<https://doi.org/10.20897/ejsteme/3964>
- 3 **The Impact of Adding Written Discourse to Six Year Olds' Mathematics Explanations within a Problem-Based Learning Unit**  
Nicole V. Gearing, Lynn C. Hart  
<https://doi.org/10.20897/ejsteme/3952>
- 4 **Social Amenities and Academic Performance in Primary Schools in Gichugu Constituency, Kenya**  
Priscah Wanjiku Githaka, Michael W. Gachahi, John Mwaruvie  
<https://doi.org/10.20897/ejsteme/3948>
- 5 **Integrating Teachers to Teach an Interdisciplinary STEM-Focused Program about Sound, Waves and Communication Systems**  
Nayif Adil Awad, Esmael Salman, Moshe Barak  
<https://doi.org/10.20897/ejsteme/5756>
- 6 **A Concrete Proposal to Introduce Control Theory to 16 Year Old Pupils**  
Leen Goovaerts, Mieke De Cock, Katrien Struyven, Wim Dehaene  
<https://doi.org/10.20897/ejsteme/5757>
- 7 **Revisiting Second Graders' Robotics with an Understand/Use-Modify-Crete (U2MC) Strategy**  
Youngkyun Baek, Sasha Wang, Dazhi Yang, Yu-Hui Ching, Steve Swanson, Bhaskar Chittoori  
<https://doi.org/10.20897/ejsteme/5772>
- 8 **Revisiting Race and Gender Differences in STEM: Can Inclusive STEM High Schools Reduce Gaps?**  
Melanie LaForce, Huifang Zuo, Kaitlyn Ferris, Elizabeth Noble  
<https://doi.org/10.20897/ejsteme/5840>
- 9 **Student Teachers' Use of Data Feedback for Improving their Teaching Skills in Science and Technology in Primary Education**  
Peter L. Bom, Maaïke Koopman, Douwe Bijaard  
<https://doi.org/10.20897/ejsteme/6285>
- 10 **Recycling Plastics: Middle School Students Create Solutions During a Summer Camp**  
Ergun Akleman, Luciana Barroso, Mary M. Capraro, Terry Creasy, Kenneth Fleming, Weiling He, Hong Liang, Ashley M. Williams  
<https://doi.org/10.20897/ejsteme/6341>



<http://www.lectitopublishing.nl>



<https://www.facebook.com/LectitoJournals/>



<https://twitter.com/lectito1>



<https://www.linkedin.com/in/lectito-journals-9a675010b/>

## Influence of Teachers Preparedness on Performance of Pupils in Mathematics in Lower Primary Schools in Aberdares Region of Kenya

Loise Wangechi Kariuki <sup>1\*</sup>, Johannes Njagi Njoka <sup>1</sup>, Zachariah Kariuki Mbugua <sup>1</sup>

<sup>1</sup> Department of Psychology & Communication Technology, Karatina University, 1957 10101 Karatina, KENYA

\*Corresponding Author: [lwangecy@gmail.com](mailto:lwangecy@gmail.com)

**Citation:** Kariuki, L. W., Njoka, J. N. and Mbugua, Z. K. (2019). Influence of Teachers Preparedness on Performance of Pupils in Mathematics in Lower Primary Schools in Aberdares Region of Kenya. *European Journal of STEM Education*, 4(1), 01. <https://doi.org/10.20897/ejsteme/3931>

**Published:** April 29, 2019

### ABSTRACT

Performance in Mathematics among pupils in lower primary schools in Kenya is a problem that continues to be a concern to parents, teachers and stakeholders in education. Teacher related factors and in particular teacher preparedness has been cited as a major contributing factor to poor teaching methods which fundamentally translates to pupils' poor performance. The purpose of the study was to evaluate the influence of teacher preparedness on pupils' performance in Mathematics in lower primary schools in the Aberdares region of Kenya. The objectives of the study were to; evaluate the influence of teachers' preparation of lesson plans on pupils' performance in Mathematics in lower primary schools and assess the influence of teachers' preparation of schemes of work on pupils' performance in Mathematics in lower primary schools from the Aberdares region in Kenya. The following hypothesis were tested; Ho1: There is no statistically significant relationship between teachers' preparation of lesson plans and performance in Mathematics among pupils in lower primary schools, Ho2: There is no statistically significant relationship between teachers' preparation of schemes of work and pupils' performance in Mathematics in lower primary schools. The study adopted the descriptive survey research design. The study was guided by the Social Constructivism Theory (SCT) advanced by Vygotsky (1978). The target population for the study consisted of all the 385 teachers and 1320 pupils in the public primary schools in Aberdares region of Kenya. A sample of schools was selected using Gay's 10-20% sampling principle which yielded a sample size of 77 teachers and 264 pupils. Data for the study was collected using questionnaires administered to the respondents. The t-test statistic was computed to test the hypothesis which stated that there was no statistically significant relationship between teachers' preparation of lessons and pupils' performance in Mathematics. The t-test yielded a p-value = 0.027 which was less than the  $\alpha$ -value of 0.05 hence the hypothesis was rejected. It was concluded that there were differences in pupils' performance in Mathematics depending on teacher preparation of lesson. Regarding the preparation of schemes of work, the computed t- test statistic yielded a p-value = .039 which was less than the p-value of .05. Therefore the null hypothesis was accepted. It was concluded that the pupils Mathematics mean scores were relatively the same regardless of whether the teacher prepared schemes of work or not. It is recommended that there is need for teachers to institutionalize as a best practice the preparation of professional documents before commencement of teaching.

**Keywords:** teacher preparedness, pedagogy, professional documents, lesson plans, schemes of work

## INTRODUCTION

Stakeholders continue to be concerned with the performance of pupils in Mathematics especially in lower primary section of education in Kenya. Performance in Mathematics among pupils in lower primary schools in Kenya has been reported to be extremely wanting. Uwezo Kenya (2016) in their report entitled, “Are our children learning?” indicated only 3 out of 10 children in Class 3 could do Class 2 work. On average, 1 out of 10 children in Kenyan primary schools were completing Class 8 without having acquired the basic competencies expected of a child completing Class 2. The persistent poor performance of pupils in Mathematics requires for investigation into the underlying variables and in particular into curriculum delivery methodologies. In the 2018 KCPE results, the mean score in the region was 35%. Oketch, Mutisya, Ngware and Sagwe (2010) assert that the competence of learners’ in numeracy and literacy in early grades affects their mastery of other aspects of the curriculum. Studies by Mtitu (2014) and Gurney (2007) identified teacher preparedness as a crucial dimension that could help improve learner’s performance in Mathematics. According to Gurney (2007), teaching is effective when teachers deliver the right content and have enough learning materials on the teaching activity. Mtitu (2014) identified that learner centered methods require teachers to actively involve students in the teaching and learning process. This requires a teacher to have passion in sharing knowledge with students while armed with appropriate tools and competencies in content delivery. Rowan and Ball (2005) state that teacher training is an important prerequisite in preparation for teaching; it involves activities such as collection of materials required for the lesson, lesson planning and assessment during the lesson, adding that teacher preparation is central to the work of teaching and functioning of an education system. Hill, Rowan and Ball (2000) argue that teacher preparedness to teaching have been identified as amongst the most critical factors that contribute to teacher’s work performance, absenteeism, burnout, and turnover in addition to having a significant influence on learners academic achievement. Therefore teachers who prepare adequately for Mathematics lessons are able to effectively deliver the Mathematics concepts to learners effectively and in a style that promotes understanding and internalization of the taught content. In agreement to this view Wilson, Floden and Ferrini-Mundy (2012) notes that teachers’ professional preparedness also encompasses the relationship that teachers have established with the learners. If the teacher has strained connection with learners, then the lesson delivery will be poor due to the emotional distance between the teacher and learners. According to Wilson, Floden and Ferrini-Mundy (2012) teacher preparedness is even more broader and encompasses the quality of their relationships with learners, fellow teachers and other school employees, specifically, the extent to which they enjoy mutual support in managing classroom instruction and interpersonal relationships in the workplace. Consequently, teachers’ preparation for teaching would require assistance from colleagues and all other stakeholders in education. Therefore when there is strained relationship in the school, the teachers’ lesson preparation may be hindered.

Bass and Ball (2000) state that research on teaching in Mathematics suggests that many teachers do not possess the prerequisite content to implement high-quality instruction. The logic underlying Bass and Ball (2000) and Kilpatrick, Swafford and Findell (2001) was that teachers who possess strong mathematical knowledge at a greater depth and span are more likely to foster students’ ability to reason, conjecture and problem-solving. They are able to more accurately diagnose and address students’ mathematical (mis)conceptions and computational (dys) fluencies. Kilpatrick, Swafford and Findell (2001) argued that teachers must deepen their knowledge of the content, including proper sequencing and closure of the topics as well as the topics that precede and follow them. Rivkin, Hanushek and Kain (2005) was of the view that central to raising student achievement in Mathematics is improving the quality of Mathematics teaching. Students who receive high-quality instruction experience greater and more persistent achievement gains than their peers who receive lower-quality instruction. They hold that students who were taught by highly effective teachers achieved a gain of 1.5 grade equivalents during a single academic year, whereas students enrolled in classes taught by ineffective teachers gained only 0.5 grade equivalents in the same year. Moreover, the effects of high-quality instruction on the academic achievement of disadvantaged students are substantial enough to counteract the host of familial and social conditions often found to impede student achievement (Rivkin, Hanushek & Kain, 2005). To put it differently, teachers are critical determinants of student learning and educational progress and thus must be well trained to use effective teaching practices. The literature discussed clearly shows that teachers’ preparation affects the performance of learners in Mathematics subject and other subjects.

Hill, Ball and Schilling (2008) posited that knowledge about content delivery methods in Mathematics differs in important ways from content knowledge possessed by the professional in the same discipline. Ball, Lubienski and Mewborn (2001) report that mathematics teachers must be proficient in not only the content, but also how to deliver the same to the students. Moreover, teachers must understand how students reason and employ strategies for solving mathematical problems and how students apply or generalize problem-solving methods to various mathematical contexts. The use of language, construction of metaphors and scenarios appropriate to teaching mathematical concepts and understanding of the use of instructional resources in the practice of teaching.



Competency in the content coupled with the proper application of pedagogical skills constitute a knowledge base for effective teaching of mathematics. These understandings represent the specialized content knowledge and preparedness. Isiugo-Abanihe, Ifeoma and Tandi (2010) emphasized that the responsibility of checking the professional documents like teachers' schemes of work and lesson plans lies in the hands of the head teacher. Preparation and use of schemes of work by the teachers enhance sequential teaching and results to improved achievement. Isiugo-Abanihe, Ifeoma and Tandi (2010) indicated that the head teachers randomly checked the teachers' schemes of work only once a term. They argued that lack of regular and close monitoring could be a factor contributing to poor performance in national examinations particularly in Mathematics. The studies have shown that there is a general consensus that teacher professional preparation contributes to academic performance of their learners. It is therefore necessary that the school administration and the teachers ensure that they prepare in advance for teaching and learning to be effective. Studies demonstrate that teacher preparation plays an important role in ensuring that learners attain better learning outcomes in education. Researches reviewed attest to the fact that better prepared teachers tend to post good grades in national examinations.

### Statement of the Problem

The influence of teacher preparedness on performance of learners especially in Mathematics in lower primary schools is not clearly documented. Attainment of knowledge in numeracy by learners in lower primary school lays an important foundation for future learning particularly in Mathematics and Sciences (Makewa, Role, Too & Kiplagat, 2012). However, reports by the Kenya National Examinations Council (KNEC) reveal that pupils' performance in Mathematics continues to decline every year. Aberdares region in Kenya has continued to post poor performance in Mathematics among the lower primary school learners (SCEO, 2015). The sub-county education office has consistently indicated that pupils are not acquiring the desired levels of competence. However, although there may be several factors that hinder learning of Mathematics, there is limited literature on studies related to teacher preparedness which is a key factor to pupils' performance. This study sought to address this gap by evaluating the influence of teacher preparedness on learners' performance in mathematics.

### Purpose of the Study

The purpose of this study was to evaluate the influence of teacher preparedness on performance of pupils in Mathematics performance in lower primary schools in Aberdares region, of Kenya.

### Objectives

The study was guided by the following objectives, which were to;

- i. Evaluate the influence of teachers' preparation of lesson plans on pupils' performance in Mathematics in lower primary schools from the Aberdares region in Kenya.
- ii. Assess the influence of teachers' preparation of schemes of work on performance in Mathematics among pupils in lower primary schools in Aberdares region in Kenya.

### Hypotheses

The study tested the following hypotheses;

**Ho1:** There is no statistically significant relationship between teachers' preparation of lesson plans and performance in Mathematics among pupils in lower primary schools.

**Ho2:** There is no statistically significant relationship between teachers' preparation of schemes of work and performance in Mathematics among pupils in lower primary schools.

### Theoretical Framework

This study was guided by social constructivism theory (SCT) advanced by Vygotsky (1978). SCT holds that all cognitive functions originate in and must be explained as products of social interactions. The theory explains that learning is not simply the assimilation and accommodation of new knowledge by learners but a process by which learners are integrated into a knowledge community. The theory stresses that learning takes place within school environments where interaction of the learners, the learning environment and the teachers ensures that learning takes place. The theory is relevant to the study because it helped to holistically analyze the variables at play during the teaching and learning processes. Constructivism theory was instrumental in analyzing the mediational role of the teacher in integrating the subject matter, the learning environment and the learner through instructional preparedness in ensuring realization of the desired learning outcomes in the learning of Mathematics.

## METHODOLOGY

The study adopted the descriptive survey research design. This research design enabled evaluation of the variables by obtaining facts and opinions without their manipulation. This design was appropriate in relation to the variables in the study because it helped to describe the situation and report as it was without their manipulation. The target population for the study consisted of all the 385 teachers and 1320 pupils in the public primary schools in Aberdares region of Kenya.

A sample of schools was selected using the Gay 10-20% sampling principle which yielded a sample size of 77 teachers and 264 pupils (see [Table 1](#)). Data was analyzed using both the descriptive and inferential statistics.

**Table 1.** Sample size

Data Set	Population	Sample Size	Percentage
Teachers	385	77	20%
Lower Primary Pupils	1320	264	20%
<b>Totals</b>	<b>1760</b>	<b>352</b>	<b>40%</b>

## RESULTS AND DISCUSSION

The results and discussion are presented in accordance with the stated objectives and hypotheses that guided the study. These were;

- a) The first research objective sought to examine the influence of teachers' preparation of lesson plans on pupils performance in Mathematics in primary schools in Aberdares Region in Kenya. The study further tabulated the pupils mean scores in mathematics in relation to teachers' preparation of mathematics lessons plans. The results presented in [Table 2](#) revealed that 23(29.9%) of the teachers did not prepare lesson plans compared to 54(70.1%) who did. The findings further established that the overall mean scores of the learners' performance in Mathematics was 59.8 and a standard deviation of 6.8. This mean score indicates that students' had an average level of competence in Mathematics. The results further revealed that pupils whose teachers prepared lesson plans performed better ( $\bar{x} = 63.9$ ) with a standard deviation of 6.31. Those teachers who did not prepare lesson plans had ( $\bar{x} = 57.3$ ) and a standard deviation of 8.01. Results suggest that teachers' preparation of lesson plans was being reflected in higher scores in Mathematics among the pupils. The findings are consistent with Rowan and Ball (2005) which reported that teacher preparation of lessons is critical in the attainment of the appropriate competencies by learners. Rowan and Ball (2005) argue that teacher preparation and commitment to teaching have been identified as amongst the most critical factors in the success and future of education.

**Table 2.** Lesson plans and pupils' performance in Mathematics

Prepared Lesson Plans	Frequency	Mathematics Mean ( $\bar{x}$ )	Standard Deviation (s)
Yes	54(70.1%)	63.9	6.31
No	23(29.9%)	57.3	8.01
<b>Total</b>	<b>77(100%)</b>	<b>59.8</b>	<b>6.83</b>

It was hypothesized that there was no statistically significant relationship between teachers' preparation of lesson plans and pupils' performance in Mathematics in lower primary schools in Aberdares region in Kenya. To test the hypothesis, t-test statistic was computed. The computed t-test yielded a p-value = 0.027 which was less than the  $\alpha$ -value of 0.05 (see [Table 3](#)). The null hypothesis was rejected and it was concluded that there was statistically significant differences in pupils mean scores among pupils in schools where teachers prepared lesson plans compared to schools where teachers did not. Teachers' preparation of lesson plans had a positive impact on pupils' acquisition of Mathematical competence. The study agreed with the findings of Armstrong, Henson and Savage (2009) who opined that teachers who planned their lessons with consideration of learners' mental abilities in mind were likely to foster learning. Armstrong, et al. (2009) argued that while teaching, the teacher should treat the content to be taught by first identifying the desired results from learning of the content. ; Secondly, break the content into smaller components or sub- tasks that logically build towards the desired results and finally, adopt appropriate teaching approaches for each of the components together with specifying the lesson objectives in relation to the grades where the learning will take place. Hence, the teaching and learning process involves meticulous treatment and preparations to ensure attainment of desired learning outcomes by the learner.

**Table 3.** Results of t-test on teachers' preparation of lesson plans and pupils mean scores in Mathematics

	Levenes Test for Equality of variances		t-test for Equality of Means						
	f	sig	t	df	sig (2tailed)	mean difference	std error difference	95% confidence of the difference	
								lower	upper
<b>equal variances assumed</b>	.268	.609	-2.565	28	.027	-.58886	.22844	-1.0538	-.1179
<b>equal variances not assumed</b>			-2.473	11.680	.030	.23694	-11.1037	-1.1037	-.0680

- b) The second objective evaluated the influence of teacher of preparation of schemes of work on pupils' performance in Mathematics in lower primary schools in Aberdares Region in Kenya. The study tested the hypothesis that there was no statistically significant relationship between teachers' preparation of lesson plans and pupils' performance in Mathematics in lower primary schools. The findings presented in **Table 4** indicate that the p-value of .039 was less than the  $\alpha = .05$ . Therefore we accept the null hypothesis. The conclusion was that there was statistically significant difference in the mean scores. The performance in Mathematics was relatively similar regardless of whether the teacher prepared schemes of work or not.

The results were divergent with the findings of Kilpatrick, Swafford and Findel (2001) who had argued that teacher's preparation was statistically related to learner's academic performance in Mathematics. The findings in this current study could be attributed to teachers experience in teaching Mathematics. Demographic data showed that majority of the teachers who were over 80% had over 5 years of teaching Mathematics. This shows that teacher experience has an influence in the attainment of learners' competencies in a particular subject. However, more research is required in order to conclusively make an authoritative verdict.

**Table 4.** Results of t-test on teachers preparation of schemes of work and pupils' performance in Mathematics

	Levenes Test for Equality of variances		t-test for Equality of Means						
	f	sig	t	df	sig (2tailed)	mean difference	std error difference	95% confidence of the difference	
								lower	upper
<b>equal variances assumed</b>	6.056	.039	.972	8	.359	4.000	4.113	-5.486	13.486
<b>equal variances not assumed</b>			.972	4.023	.386	4.000	4.113	-7.389	15.389

## CONCLUSION

The findings of the study indicate that teacher preparedness as indicated by preparation of lesson plans had an influence on pupils' performance in Mathematics in lower primary school. Preparation of schemes of work had no influence on performance. There were statistically significant differences between pupils mean scores for schools where teachers prepared lesson plans and those who didn't. However, the study established that there was no statistically significant difference in the pupils' performance in relation to teachers' preparation of schemes of work.

## RECOMMENDATIONS

Arising from the findings of this study, we recommend the need for teachers in lower primary schools to always prepare for their lessons before commencement of teaching. The Ministry of Education should always emphasize that teachers must prepare prerequisite professional documents that are instrumental in enhancing learning outcomes among learners especially that of Mathematics in the lower primary segment of education. Teachers who fail to comply with this requirement should be severely censured.

## REFERENCES

- Akatekit, D. D. (2000). *An evaluation of teachers' methods in P310/3 (Novels)*. Dissertation submitted for the degree of Master of Education at Makerere University. Kampala
- Armstrong, D. G., Henson, K. T. and Savage, T. V. (2009). *Teaching today: An introduction to education* (8<sup>th</sup> ed.). Upper Saddle River, New Jersey, OH: Pearson.
- Ball, D. L. and Bass, H. (2000). Interweaving content and pedagogy in teaching and learning to teach: Knowing and using mathematics. In J. Boaler (Ed.), *Multiple perspectives on the teaching and learning of mathematics* (pp. 83–104). Westport, CT: Ablex.
- Gay, L. R. (2006). *Educational Research: Competencies for analysis and application* (5<sup>th</sup> ed.). Englewood Cliffs, NJ: Prentice-Hall.
- Gurney, P. (2007). Five Factors for Effective Teaching. *New Zealand Journal of Teachers' Work*, 4(2), 89-98.
- Hill, H. C., Ball, D. L. and Schilling, S. G. (2008). Unpacking pedagogical content knowledge: Conceptualizing and measuring teachers' topic-specific knowledge of students. *Journal for Research in Mathematics Education*, 39(4), 372–400.
- Hill, H. C., Rowan, B. and Ball, D. L. (2005). Effects of teachers' mathematical knowledge for teaching on student achievement. *American Educational Research Journal*, 42(2), 371-406. <https://doi.org/10.3102/00028312042002371>
- Isiugo-Abanihe, M., Ifeoma, L. and Tandi, I. (2010). Evaluation of the Methodology Aspect of Science Teacher Education Curriculum in Nigeria. *Pakistan Journal of Social Sciences*, 17(2), 170-176. Available at: <http://www.medwelljournals.com/fulltext/?doi=pjSsci.2010.170.170>
- Kilpatrick, J., Swafford, J. and Findell, B. (Eds.). (2001). *Adding it up: Helping children learn mathematics*. Washington DC: National Academies Press.
- Makewa, L. N., Role, E., Too, J. K. and Kiplagat, P. (2012). Teacher commitment and mathematics performance in primary schools: A meeting point!. *International Journal of Development and Sustainability*, 1(2), 286–304.
- Mtitu, E. A. (2014). *Learner-centred teaching in Tanzania: Geography teachers' perceptions and experiences*. Victoria University of Wellington.
- Oketch, M., Mutisya, M., Ngware, M. and Sagwe, J. (2010). Teacher math test scores: Classroom teaching practices and student achievement in Kenya. *Working paper, African Population and Health Research Center (APHRC), Shelter Afrique Center, Nairobi*.
- Rivkin, S. G., Hanushek, E. A. and Kain, J. F. (2005). Teachers, schools, and academic achievement. *Econometrica*, 73(2), 417–458. <https://doi.org/10.1111/j.1468-0262.2005.00584.x>
- Uwezo (2016). *Are Our Children Learning?* Uwezo Kenya Sixth Learning Assessment Report. Nairobi: Twaweza East Africa.
- Vygotsky, L. S. (1978). *Mind in Society: The Development of Higher Psychological Processes*. Cambridge, MA: Howard University Press.
- Wilson, S. M., Floden, R. E. and Ferrini-Mundy, J. (2012). Teacher preparation research: An insider's view from the outside. *Journal of Teacher Education*, 53(3), 190-204. <https://doi.org/10.1177/0022487102053003002>

## Developing a Module to Teach Thermodynamics in an Integrated Way to 16 Year Old Pupils

Leen Goovaerts <sup>1\*</sup>, Mieke De Cock <sup>2</sup>, Katrien Struyven <sup>3,4</sup>, Wim Dehaene <sup>1</sup>

<sup>1</sup> ESAT-MICAS, Faculty of Engineering Science, KU Leuven, BELGIUM

<sup>2</sup> Faculty of Science, Department of Physics and Astronomy, KU Leuven, BELGIUM

<sup>3</sup> Hasselt University, School for Educational Studies, BELGIUM

<sup>4</sup> Vrije Universiteit Brussel, Educational Sciences Department, BELGIUM

\*Corresponding Author: [leen.goovaerts@kuleuven.be](mailto:leen.goovaerts@kuleuven.be)

**Citation:** Goovaerts, L., De Cock, M., Struyven, K. and Dehaene, W. (2019). Developing a Module to Teach Thermodynamics in an Integrated Way to 16 Year Old Pupils. *European Journal of STEM Education*, 4(1), 02. <https://doi.org/10.20897/ejsteme/3964>

**Published:** April 29, 2019

### ABSTRACT

In order to motivate secondary school pupils for STEM studies and professions, a teaching approach with a focus on integration of STEM components is developed. This paper focuses on the integration of physics and mathematics into an engineering design problem in K10 education, namely building and heating a model of a passive house with a sun boiler. Specific attention is given to the core ideas of integrated STEM while developing this module. These applied ideas comprise problem-centered and cooperative learning, with explicit attention to research and design, as well as taking into account results from discipline specific educational research results.

**Keywords:** thermodynamics, secondary education, problem-based learning

### INTRODUCTION

The current industry in Flanders (Belgium), and in the rest of the Western world, has lack of scientists, technicians and engineers (Van den Berghe and De Martelaere, 2012; Eng, 2014; Act, 2012). The choice for these STEM (Science, Technology, Engineering and Mathematics)-professions is made early in the educational careers of pupils depending on their enthusiasm for and view on these professions. The lack of scientists, technicians and engineers has three reasons. Firstly, current secondary school curricula don't always succeed in showing the content of these jobs, because concepts of different fields are taught in separate courses, while STEM-professions typically rely on integration of concepts from different fields (Eng, 2014). Secondly, the separation of school subjects and the lack of integration between them, makes specific course topics less relevant for pupils (Mehalik et al., 2008). Thirdly, authentic problems are neglected because they require integration of different subjects. Due to this, pupils are not aware of the societal relevance of their course content (Pro, 2014; Sjøberg and Schreiner, 2010; Stuckey et al., 2013). Teaching STEM in an integrated way is put forward as a possible solution to these challenges. This integrated STEM, also named iSTEM, focuses on integration between the different components of STEM. In general, recent research has shown promising results on attitude, motivation and learning outcomes of integrating courses (James et al., 2000; Ross and Hogaboam-Gray, 1998; Lam et al., 2008; Becker and Park, 2011).

Although the number of studies on integrated STEM education is increasing, in depth research on the effect of it is still missing. Moreover, details about the developed learning materials and teaching method are often not described.

STEM@school is a research project in which a new teaching method for integrated STEM education in secondary school is developed and validated. This includes the design of learning materials that are centered around authentic problems in which the integration of the different S-T-E-M components is made explicit. The framework of this teaching and learning approach is described in Thibaut et al. (2018).

In this paper, one of the designed iSTEM projects in which the central challenge is to build a passive house, heated with a sun boiler, is presented. This iSTEM project is a translation of the iSTEM-framework of Thibaut et al. (2018) in a concrete learning module. First the STEM@school setting and framework is elaborated. Then, the design process itself is described, linking the concrete material to the underlying ideas. Finally, the learning module is described, with explicit attention to the motivation of the choices made and implementation of the discipline specific educational research results.

## **STEM@SCHOOL**

The described material in this paper is developed in the context of the STEM@school project. The main aim of the project is to develop and validate a learning environment for integrated STEM education in secondary school and as such contribute to the development of research based STEM education.

The project is a collaboration between academic researchers in Science, Engineering, Science education, and Educational sciences on the one hand and secondary school teachers and umbrella organizations on the other hand. This multidisciplinary collaboration ensures the research is relevant for real school practice and the engagement of policy makers increases chances for long term implementation of developed ideas.

The described project team has developed a new teaching approach, with a concrete translation into learning modules. Five central ideas are considered to be essential in the development of the learning materials (Thibaut et al., 2018): integration of different STEM disciplines, problem-centered and cooperative learning, with explicit attention to research and design, as well as the application of discipline specific educational research results. These underlying ideas are explained in detail below.

Since educators recognize the value of pupils understanding the connections and differences between different disciplines (Huntley, 1998; Wicklein and Schell, 1995), and research shows promising results on attitude, motivation and learning outcomes of integrating courses (James et al., 2000; Ross and Hogaboam-Gray, 1998; Lam et al., 2008; Becker and Park, 2011), integration between different disciplines plays a central role in the teaching approach of STEM@school. Nowadays, Christiansen and Rump (2008) indicate that pupils fail to see the connection between mathematics and physics, because physics is rarely mentioned in mathematics class.

A second key concept in the teaching method of STEM@school is the fact that learning should be problem-centered. This approach is adopted to show to pupils that a real problem can seldom be solved by applying ideas from only one discipline, but that a solution requires use and integration of ideas and techniques from different disciplines (Dym et al., 2005). Furthermore, research indicates pupils are more willing to learn when their knowledge is necessary to solve a real-world problem (Dym et al., 2005).

Thirdly, cooperative learning involves pupils working together on an assignment. This cooperation requires active participation of pupils (Isık and Tarım, 2009). Furthermore, dialogues between pupils during the collaboration take place in the zone of proximal development, which provides a unique learning environment for the pupils (Fosnot and Perry, 1996). Another reason to adopt cooperative learning in the new teaching strategy, is that cooperation is a basic competence for STEM professionals (Dym et al., 2005).

A fourth demand of the STEM@school teaching method, is the fact that pupils engage in doing research and design while solving the problem. Pupils need to be trained in doing all stages of the research and design cycle (Wallin et al., 2016; Mehalik et al., 2008; Dym et al., 2005). This full engagement is important, because when they are only involved in one aspect, pupils will miss the shortfalls of the used method, in the other steps. For example, when pupils are only engaged in data collection, they have no clue of the problems occurring in data analysis. While being actively involved in this process, pupils should realize a fixed path to a solution is a utopia (Banks and Barlex, 2014).

Last but not least, developers of learning material used in STEM@school have added an extra key concept to iSTEM while developing, compared to the framework of Thibaut et al. (2018). Developers need to take discipline specific educational research results into account. In discipline specific educational research, researchers study the teaching and learning of discipline specific ideas, concepts and methods. Ultimately, this results in teaching strategies that support the learning process. Results from this discipline specific educational research are taken into account in the learning module. In this paper, the decisions based on discipline specific educational research are made explicit and explained.

As shown above, literature proves these ideas, problem-centered and cooperative learning, with explicit attention to research and design, as well as taking into account discipline specific educational research results,

comprise promising learning outcomes, all by themselves. By combining these ideas, the assumption is that maximal learning gain occurs (Mehalik et al., 2008).

Based on the central ideas, different learning modules are developed and implemented in a new course named STEM, in secondary school. In this course, pupils invoke content covered in their other science and mathematics courses. The introduced challenge, which represents the problem, is a stepping stone to the compulsory scientific and mathematical topics. Pupils encounter the challenge in the STEM-course, get stuck and need to combine ideas and concepts that are discussed in different other courses. By applying this approach, pupils are shown the substantive relevance of the different course topics and of science, technology, engineering and mathematics (Ríordáin et al., 2016; Mehalik et al., 2008; Wicklein and Schell, 1995). Furthermore, pupils develop a sophisticated understanding of STEM studies and professions. This facilitates their decision making when choosing a study or profession (Kelley and Knowles, 2016).

STEM@school not only creates an additive course in secondary schools, moreover, a complete integrated STEM-curriculum (Goovaerts et al., 2016) is obtained, as explained below. In this newly developed course, namely the STEM-course, linking with the current science and mathematics courses is crucial (Veretennicoff and Vandewalle, 2015). To create this integrated STEM-curriculum, some requirements need to be fulfilled (Heil et al., 2013). A horizontal alignment of content over the different STEM courses is crucial. This alignment is necessary because two or more disciplines need to be addressed at the same time in order to talk about integrated STEM. When this content is taught just in time, pupils will see the relevance of the content (Ross and Hogaboam-Gray, 1998). On top of that, STEM@school encourages pupils to transfer concepts of one specific discipline to another. Therefore, the concepts need to be abstracted into models and applied in a new context or the other way around, in other words, by forward-reaching-high road transfer or backward-reaching high road transfer (Perkins and Salomon, 1988). Perkins and Salomon (1988) describe forward-reaching-high road transfer 'as one learns something and abstracts it in preparation for applications elsewhere.' On the contrary, when 'one finds oneself in a problem situation, abstracts key characteristics from the situation, and reaches backward into one's experience for matches' is defined as backward-reaching-high road transfer. So, specific attention in the learning modules for abstracting and model thinking, facilitates transfer.

## APPROACH TO THE DEVELOPMENT OF AN iSTEM LEARNING ENVIRONMENT

### Design Teams

Together with teachers, the development team of STEM@school began a brainstorm for developing a new integrated STEM module for the 4th year of Flemish secondary school. This collaboration is a conscious choice of the project team. First of all, teachers have everyday classroom experience with pupils. As a result, they are in the best place to estimate the level of competence of the pupils. In addition, secondary school teachers are familiar with the course content of the curriculum. The development team of the project, on the other hand, has innovative ideas about the teaching approach and course content. Supported by Flanders' educational umbrella organizations, this collaboration provides a broad support base for the newly developed teaching approach.

Some schools in Flanders volunteered for developing learning modules. Each of those schools has composed a team of several teachers, to develop a module in collaboration with researchers. This team is mostly a mixture of undergraduate and graduate teachers, specialized in different courses. This mixture of specialization is necessary because teachers aren't aware of the conceptions of neighboring courses. This awareness is necessary to make explicit connections or differences in meanings of concepts between scientific specialties (Christiansen and Rump, 2008). The mixture of undergraduate and graduate teachers implies other advantages, as described below. An undergraduate teacher is a teacher with a bachelor degree. In this education, future teachers are trained on course content described in the curriculum guidelines and teaching approaches. Furthermore, they are only allowed to teach in the first four years of secondary education. A graduate teacher holds a master degree in a specific discipline and followed a teacher training program afterwards. Sometimes, these teachers first gain industrial working experience before teaching. These teachers can teach from the 3rd until the 6th year of secondary education. A mixture of these types of teachers covers the course content of the whole secondary school and combines different views on teaching.

### Content Integration

In Flemish secondary education, detailed curriculum guidelines apply, and teachers are expected to implement them. This rigid structure makes it almost impossible to change the content of the courses, neither by the teacher, nor by the developers. Given the Flemish curricula for the 3rd and 4th year, an engineering or research project, integrating physics and mathematics, is the most obvious. This integration is limited to these courses due to several reasons. First of all, the link between mathematics and physics is more obvious than other sciences during the 3rd



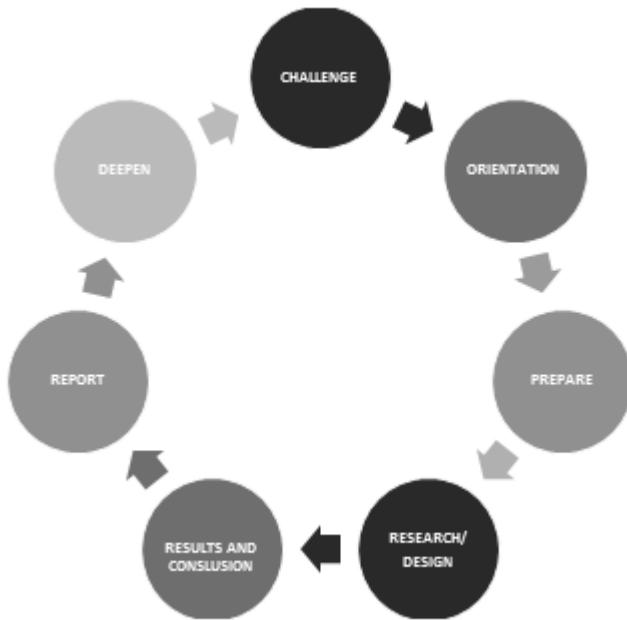

Figure 1. Legacy Cycle

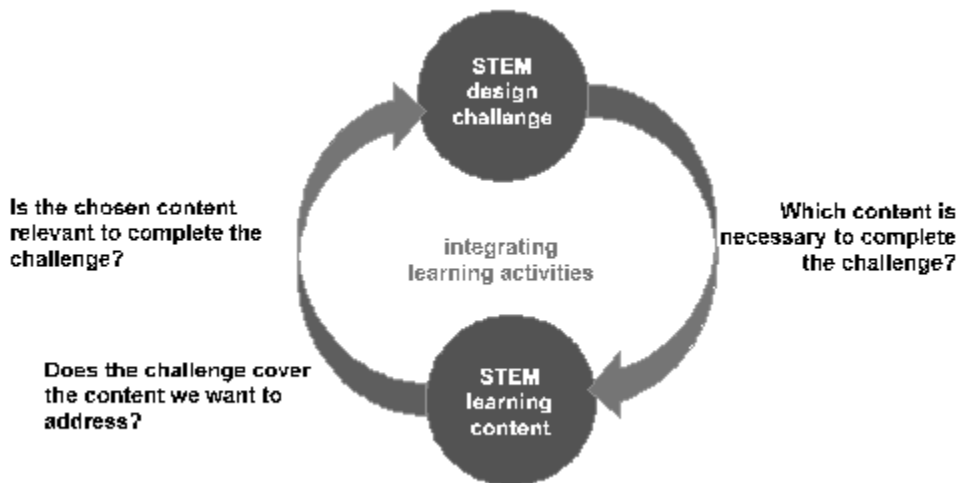

Figure 2. Iterative development process

and 4th year of Flemish secondary school. Secondly, the content of the other sciences in the 3rd and 4th year of Flemish secondary education is less suited to define a project integrating these subjects.

Besides the typical school's content knowledge, the procedural problem solving knowledge is very important for pupils to learn, because the engineering part mostly consists of procedural knowledge in order to solve a problem. In case of STEM@school, pupils should use a design or research cycle. The cycle used is the Legacy Cycle (Klein and Sherwood, 2005), presented in Figure 1. The developers design the modules to force pupils in an implicit way to use the legacy cycle. Pupils should use it in order to solve the engineering or research challenge.

The development process of the learning material is a compact design cycle, as presented in Figure 2. An iterative process needs to be done between the challenge and the learning topics. This iteration needs to assure that the selected content is relevant in completing the challenge. The concerned teachers attach great importance to this iteration, because they think pupils will lose their interest in the STEM-course from the moment that the provided content isn't relevant anymore to the challenge. However, the same teachers are willing to change the challenge in order to integrate some more course content.



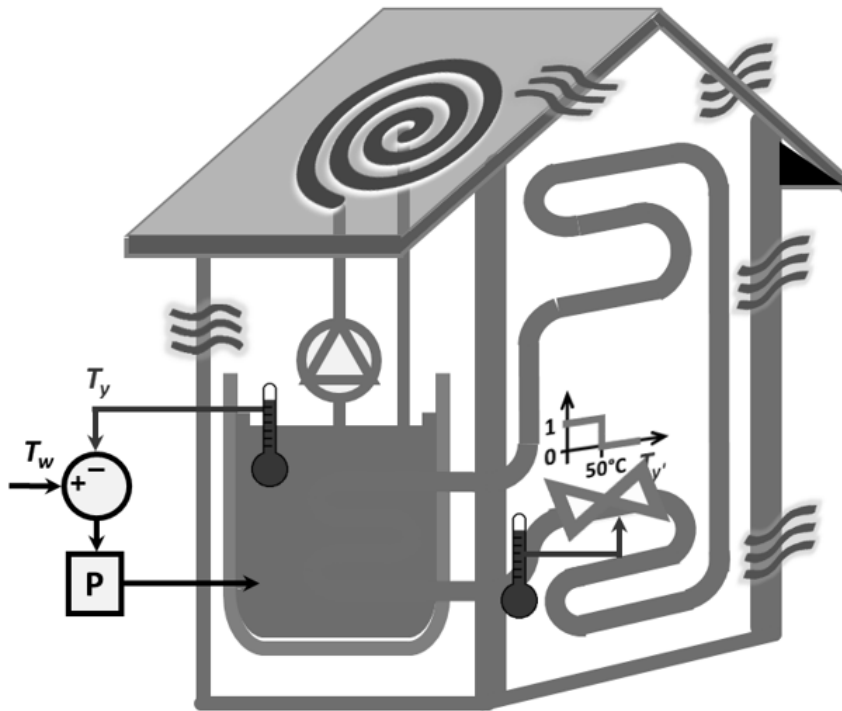

**Figure 3.** Schematic presentation of the challenge of the passive house

## PASSIVE HOUSE AS A CONTEXT

### Challenge

The physics curriculum for the 4th year of secondary education focuses on three main themes: work, energy and power; pressure and gas laws; and heat. In mathematics, topics related to both geometric and analytic description of the circle, quadratic equations and geometric sequences are dealt with. Taking these curriculum guidelines into account, a project relevant to students and relating to the mentioned content was selected. Finally the challenge was formulated as “Design and develop a model of a passive house with a sun boiler that heats the house and control the temperature in the house”. This STEM-design challenge is presented in **Figure 3**. In this figure a sun boiler is placed on top of the roof. Through a tank, this boiler will provide the hot water for the floor heating of the house. The waves through the walls represent the heat losses to the environment. The loop and graph in the figure illustrate the control system of the house. The description of the control system is beyond the scope of this paper, but is explained in another paper (Goovaerts et al., submitted). The present paper explains how science and mathematics are integrated to design and develop a passive house with a sun boiler.

The choice to formulate a STEM-design challenge about heat, is supported by Papadouris et al. (2008). They claim any teaching approach for energy has to be integrative, in order to expose students to all fundamental aspects of energy as a physical quantity.

### Content

A major argument for the choice of an iSTEM-design challenge on heat and thermodynamics, relates to the learning goals in the established, existing curriculum for the fourth year of physics. According to the prescribed curriculum goals, pupils need to learn about calorimetry. More specifically, they are trained to calculate the temperature rise or added amount of heat during an experiment with a calorimeter. Unfortunately, they don't need to study heat transport. However, every real world heat problem contains heat losses by heat transport, so this content is added to the STEM-course. While treating this concept, pupils learn how to calculate heat losses through the walls and windows of a house.

To relate to the mathematics curriculum, the analytic and geometric approach of the circle is used to build the roof. Pupils are forced to build a roof with a circular support. As a result of this decision, pupils need to formulate the equation of the circle and the tangent to the circle, since the roof is supported by the circle. The intersection

of the tangent and the circle is the juncture of the roof. This reveals the relevance of the equations of the circle. Other mathematics concepts are necessary while controlling the temperature. Geometric sequences can be used to predict the behavior of the system, since solving differential equations is not yet taught to the pupils. (Goovaerts et al., submitted)

## SET UP OF THE LEARNING MATERIALS

### Script

Once the challenge is formulated, it is split in several submodules. First of all, a sun boiler needs to be build. Secondly, the walls of the house need to be build and insulated. Thirdly, the roof with a circular support needs to be put upon the walls. Finally, the sun boiler needs to be connected with the floor heating of the house and the temperature should be actively controlled. This last part is beyond the scope of this paper, but is described in another paper (Goovaerts et al., submitted).

The first submodule is provided and contains the general storyline, referred to as the script. In this submodule a reference to the other submodules is made, when the content of this submodule is necessary in order to progress in the challenge. This approach results in learning materials of a Babylonian style, with more emphasis to useful models and systems instead of focusing on axioms (Christiansen and Rump, 2008). This Babylonian style focuses on the applicability of the learned knowledge, in contrast to the Euclidian style, in which the focus is on axioms and deductivity. The Babylonian style is only used in the STEM-course, where the developed learning modules are used, since the other courses retain their identity, meaning they are taught in a more classic way. The other submodules deal with the building of the sun boiler, the house and controlling the temperature in the house. All submodules contain references to relevant chapters in textbooks. The content of the regular courses is not redeveloped. Consequently, the changes in the regular courses are reduced to a minimum (He et al., 2016).

The script for this challenge contains references to six submodules, as listed below.

- (1) The challenge
- (2) Energy in a house
- (3) The sun boiler
- (4) The passive house
- (5) Heating the house with the sun boiler
- (6) The result

Each submodule is briefly described below, with special attention to the central ideas of STEM@school, namely integration, problem-centered and cooperative learning, research and design learning, and discipline specific educational research input.

### Summaries in the Script

Due to the use of submodules, the total knowledge is fragmented. Therefore, some summaries are embedded in the script to keep pupils on track and select the important issues and formulas. After such a summary, some specific questions about misconceptions are posed. These questions were validated by Yeo and Zadnik (2001) and are proven to be effective in revealing thermodynamic misconceptions by pupils. The teachers are advised to treat these questions in a peer instruction setting (Jasien and Oberem, 2002; Baser, 2006). Together with the concepts, the solutions to these questions are provided for the teacher, with extra explanation. Teachers are also taught, when detecting a misconception, a demonstration or experiment needs to be shown to the pupils and cause a conflict between the student's conception and the newly observed phenomena. Afterwards, a solution needs to be searched in order to solve the misconception (Trumper, 1997; Doménech et al., 2007; Baser, 2006).

### The Challenge

The challenge is described for the pupils in the following way: 'You should build a model of a passive house, heated by a sun boiler and underfloor heating. Being sparingly with energy has become a socially relevant topic. We need to make sure that houses are well insulated and use alternative energy sources.' The challenge presented here resembles a lot to the challenge posed by Schnittka et al. (2010), but in another, more applicable format.

### Energy in a House

In the first step to complete the challenge, pupils need to learn about heat. To make them familiar with the ideas and concepts, pupils study the heat consumption in their own house. After this study, they get more information on renewable energy and the typical problems about energy.

It is important to give pupils insight in the issue of 'shortage of energy'. Pupils should be taught that energy can't be lost, although this is what media write and people say. This results in a misconception by pupils. They

should learn that energy can be transferred (converted) into other, less useful forms of energy (Doménech et al., 2007; Kaper and Goedhart, 2002) and as such is lost for further use. This misconception is already treated in the first two years of secondary education, so pupils only need to be reminded for that.

### **The Sun Boiler**

After the exploration phase, it is time to work on the challenge itself. As the challenge describes, a sun boiler needs to be built. In this submodule and in parallel with the physics course, pupils learn about heat capacity and thermal equilibrium, which are crucial aspects in learning thermodynamics (Carlton, 2000; Arnold and Millar, 1996). These concepts are best explained by the kinematic molecular theory (Wiser and Amin, 2001; Carlton, 2000). When using these concepts in order to explain heat capacity, the transfer to upcoming concepts as latent heat, will be much easier.

An analogy is used to make pupils confident with the concept of thermal equilibrium. Arnold and Millar (1996) described an analogy with water flow. Pupils are demonstrated a glass of water with an inflow and an outflow. Next, they are asked how to adapt the flows in order to keep the water level constant, raise or decrease. The water level then becomes the equivalent of the thermal equilibrium, which makes clear that the net flow needs to be zero in order to be in balance.

Once the pupils master the concept of heat capacity, they can use this to select the best material to build a sun boiler. Therefore, pupils conduct some experiments. Giving enough freedom during the experiments, makes them feel more satisfied and important making the decisions. So more open-ended experiments are recommended. (Berg et al., 2003). This freedom can be practiced in different gradients. The most freedom is given when pupils are asked to design a set of experiments in order to choose the best materials to build a sun boiler. An intermediate form is to discuss with them which experiments need to be set up, but let them design the experiments themselves. The minimum amount of freedom that is still acceptable is given when the experiments with the different steps are given to the pupils, but the pupils are free to choose the amount of the concerned materials. In the latter, pupils are forced to think about the constants, parameters, dependent and independent variables. As a result, the experiments will not become a simple cooking book experiment. As mentioned before, the more freedom pupils get, the more ownership they gain of the experiment. Though, because of boundary conditions, it is not always possible to give so much freedom to the pupils. The amount of time devoted to the STEM-course is limited and since freedom asks a lot of extra time, freedom can be restricted. Another reason to limit the freedom of pupils, is that the materials available in the school are below par. In the module different stages of freedom are presented to the teachers.

The necessary experiments provide an ideal climate to force pupils to interpret graphs in a physical context. Research has demonstrated pupils feel unconfident and unable to do this, because they have troubles in making a connection between a graphical representation and the physical process it represents (Jasien and Oberem, 2002; Boohan et al., 2001). In this context for example, pupils need to measure the temperature over time of three equal reservoirs, only their colors differ. The pupils are asked to put these data into a graph and select the most appropriate color. Consequently, they have to use their mathematical knowledge about graphs and slopes in order to make a physical conclusion.

In a final stage, the efficiency of the sun boiler needs to be calculated. It's important to check how much power is necessary to reach a certain amount of heat in the water, especially in the current debates on alternative energy. Moreover, proving and improving efficiency is a daily goal of an engineer. Since pupils have to solve an engineering challenge, efficiency will always be a part of it. Besides the social relevance of efficiency, it is part of the curriculum goals, imposed by the government and therefore important to include in the project.

### **The Passive House**

Besides the sun boiler, a model of a passive house needs to be made. The first step is to build a house, the second step is to make the house as passive as possible. In order to build the house, pupils receive the dimensions of the rectangular house. These dimensions are important, because the scaling factor relative to a real house needs to be correct, otherwise it is impossible to heat the house with the floor heating. When pupils received the dimensions, they go to work to design the floor and the walls. To design the roof, they need extra mathematical knowledge. The roof is a triangle, supported by half a circle. Hence, pupils have to calculate the characteristics of the circle, such as the radius and the points of tangency with the roof. This calculations can be done using an analytical or geometric approach, depending on the knowledge of the pupils and the curriculum guidelines. This step needs to be done before building the house itself, because the different parts of the house are laser cut, so the design has to be correct from the beginning. It is important to integrate mathematical calculations in the design process, so pupils are aware that the design process has a scientific ground.

Next, the house needs to be insulated to obtain a passive house. To obtain a relevant insulation and the necessary calculations, knowledge about heat transport is required. Pupils are first given a brief introduction about

the different types of heat transport, such as conduction, convection and radiation. To make sure pupils can distinguish these types of heat transport, some everyday life situations are discussed. The presented examples are already researched and found useful for pupils of secondary school. For example, the thermos is designed in order to obstruct multiple forms of heat transport (Lewis and Linn, 2003).

The following lessons focus on heat conduction, because it is the most important form of heat transport when insulating houses. The concept of the heat conduction coefficient is explained and linked to the terms insulator and conductor. To clarify to pupils that a material will never be an ideal insulator or conductor, various materials are presented at a continuum (Lewis and Linn, 2003). Various conceptual questions are posed to the pupils, in order to eliminate misconceptions. A frequently appearing misconception is that two or more objects are at a different temperature, because they don't feel as equally hot, although they are in the same room. This idea typically leads to the misconception that metals are naturally colder than non-metals (Schnittka and Bell, 2011; Frederik et al., 1999; Carlton, 2000; Sözbilir, 2003; Lewis and Linn, 2003). Some examples are discussed during the course in order to clarify to pupils that a conductor always feels colder than an insulator although they are at the same temperature, because a conductor immediately conducts the heat of the body (Lewis and Linn, 2003). Another addressed misconception is that insulators keep cold out (Schnittka and Bell, 2011). Pupils should be aware of the fact that insulators obstruct the natural flow of heat, from the hot places to the cold places. This misconception is addressed by letting pupils think about the temperature inside the house during hot summer days in comparison with cold winter days.

In this phase, pupils are able to calculate the heat loss through the walls and windows of the house. The next step is to investigate whether the chosen insulation material will be good enough. The losses to the outside depend on the temperature of the inside. The temperature of the inside raises according to the heating time. At a certain point, the heat losses will be equal to the power to warm the house, consequently the equilibrium temperature is reached (Arnold and Millar, 1996). And this equilibrium temperature should be a lot higher than the desired temperature, because otherwise it is impossible to reach the desired temperature. This whole process of the equilibrium temperature can be explained with the same analogy used to explain thermal equilibrium (Arnold and Millar, 1996), mentioned before.

### **Heating the House**

Of course, it is important to assure that the house can be heated with the sun boiler and the temperature can be set. First pupils should learn how to control the temperature in the house. Therefore, some basic knowledge about control engineering is necessary. How this should be handled for pupils is described in another paper (Goovaerts et al., submitted). To make the control process easier, pupils can start by using a power resistor. In this case, the power put in the house is invariable, which is easier to calculate.

The end goal is to heat the house with the heated water of the sun boiler. To reach this goal, pupils should build a floor heating system in the house. With the length of the floor heating and the dimensions of the sun boiler, pupils can calculate if it's possible to reach the desired temperature and how long it takes for the house to heat up. Though, a few simplifications are necessary in order to facilitate pupils to make these calculations. The first assumption clarifies that the temperature of the water in the floor system is the same at all places in the system. The conducted heat only lowers the temperature when the used fluid leaves the tubes in the floor. Since the temperature in a realistic situation would vary over time and place, a tough integral and differential equation would need to be solved. Because this is far above the heads of 16-year old pupils, the mentioned simplification is necessary. Another assumption is that the temperature in the house stays at the begin temperature until enough heat is provided to reach the desired temperature. The transient response of the heating system itself is ignored.

### **The Result**

When all previous steps are completed, the sun boiler can be connected and the house should be heated with the sun boiler. Now, pupils need to reflect on the task. It is time to catalogue what went good, what went wrong, how the design can be adapted in order to improve the efficiency of the sun boiler or the heating of the house, . . . Pupils now finally see the whole solution of their initial challenge. Pupils feel proud to have completed the challenge.

Also a check with governmental rules about heat energy and heat losses in houses is done. As a conclusion, this learning module has covered all curriculum guidelines concerning heat. The experimental approach requires more time investment, but involves a deeper learning of the concepts, with less misconceptions.

## **IMPLEMENTATION OF THE LEARNING MODULE IN THE CLASSROOM**

The presented learning module is tested a first time in 30 schools in Flanders. Through meetings with the teachers and questionnaires, feedback is collected.

Teachers mentioned an increase in motivation for learning the concepts of heat and doing the experiments. According to the teachers, this is owing to the context in which pupils need to complete the experiments in order to complete the proposed challenge. Moreover, teachers claimed pupils have a better view on the concept of heat because of the conducted study in their own house.

Although most teachers don't study results of discipline specific educational research themselves, they reported they have worked explicitly on the presented misconceptions in the module.

Unfortunately, building the passive house as well as the sun boiler seemed to be too time consuming, so teachers needed to make choices. Some teachers decided to build the house this year and the sun boiler next year, or the other way around. Others opted to split the class and let half the class make the house and the other half the sun boiler.

## CONCLUSION

A new approach to teach concepts related to heat and heat transport in secondary school is described, which integrates physics and mathematics in an engineering design problem, taking into account results from discipline specific educational research. While solving this engineering design challenge, pupils become aware of the necessity of integrating science, mathematics and technology. Furthermore, every design team will follow its own path in solving the challenge, yet led by a research or design cycle. Thus, they feel free and in charge. Being a real world problem to solve, pupils are able to contact experts, link it to the news and compare their solution to the existing ones.

An advantage of this approach is that pupils immediately grasp the relevance of subject matter provided in separate STEM courses, which increases their motivation. Moreover, we expect pupils to gain a deeper level of understanding the content knowledge because of the relevance and specific attention to certain parts. This increased motivation, knowledge and awareness makes sure, pupils can make a more motivated choice regarding their future studies and profession.

## ACKNOWLEDGEMENTS

The work described in this paper is founded by Flemish government under the IWT-SBO project STEM@school.

Special thank you to Jolien De Meester for illustrating this engineering design challenge.

Thanks to my colleagues in this project, Stijn Ceuppens, Jolien De Meester and Lieve Thibaut, for the discussions about the content and teaching approach.

## CONFLICT OF INTEREST

On behalf of all authors, the corresponding author states that there is no conflict of interest.

## REFERENCES

- (2012). *Actieplan voor het stimuleren van loopbanen in wiskunde, exact wetenschappen en techniek*. Technical report, Vlaamse overheid. 14
- (2014). *Engineering UK 2014 The state of engineering*. Engineering UK.
- (2014). *Project STEM: Book of insights*. Mindshare.
- Arnold, M. and Millar, R. (1996). Learning the scientific story: A case study in the teaching and learning of elementary thermodynamics. *Science education*, 80(3), 249–281. [https://doi.org/10.1002/\(SICI\)1098-237X\(199606\)80:3<249::AID-SCE1>3.0.CO;2-E](https://doi.org/10.1002/(SICI)1098-237X(199606)80:3<249::AID-SCE1>3.0.CO;2-E)
- Banks, F. and Barlex, D. (2014). *Teaching STEM in the secondary school: Helping teachers meet the challenge*. Routledge. <https://doi.org/10.4324/9780203809921>
- Baser, M. (2006). Fostering conceptual change by cognitive conflict based instruction on students understanding of heat and temperature concepts. *Eurasia Journal of Mathematics, Science and Technology Education*, 2(2), 96–114. <https://doi.org/10.12973/ejmste/75458>
- Becker, K. and Park, K. (2011). Effects of integrative approaches among science, technology, engineering, and mathematics (stem) subjects on students' learning: A preliminary meta-analysis. *Journal of STEM Education: Innovations and Research*, 12(5/6), 23.

- Berg, C. A. R., Bergendahl, V. C. B., Lundberg, B. and Tibell, L. (2003). Benefiting from an open-ended experiment? A comparison of attitudes to, and outcomes of, an expository versus an open-inquiry version of the same experiment. *International Journal of Science Education*, 25(3), 351–372. <https://doi.org/10.1080/09500690210145738>
- Boohan, R., Stylianidou, F. and Ogborn, J. (2001). Teaching about energy and training for innovation. *Physics Teacher Education Beyond 2000*, 177–180.
- Carlton, K. (2000). Teaching about heat and temperature. *Physics Education*, 35(2), 101. <https://doi.org/10.1088/0031-9120/35/2/304>
- Christiansen, F. V. and Rump, C. (2008). Three conceptions of thermodynamics: Technical matrices in science and engineering. *Research in Science Education*, 38(5), 545–564. <https://doi.org/10.1007/s11165-007-9061-x>
- Doménech, J. L., Gil-Pérez, D., Gras-Martí, A., Guisasola, J., Martínez-Torregrosa, J., Salinas, J., Trumper, R., Valdés, P. and Vilches, A. (2007). Teaching of energy issues: A debate proposal for a global reorientation. *Science & Education*, 16(1), 43–64. <https://doi.org/10.1007/s11191-005-5036-3>
- Dym, C. L., Agogino, A. M., Eris, O., Frey, D. D. and Leifer, L. J. (2005). Engineering design thinking, teaching and learning. *Journal of Engineering Education*, 94(1), 103–120. <https://doi.org/10.1002/j.2168-9830.2005.tb00832.x>
- Fosnot, C. T. and Perry, R. S. (1996). Constructivism: A psychological theory of learning. *Constructivism: Theory, perspectives and practice*, 2, 8–33.
- Frederik, I., Der Valk, T. V., Leite, L. and Thorén, I. (1999). Pre-service physics teachers and conceptual difficulties on temperature and heat. *European Journal of Teacher Education*, 22(1), 61–74. <https://doi.org/10.1080/0261976990220105>
- Goovaerts, L., De Cock, M. and Dehaene, W. (2016). *Assessment of stem-design challenges: review and design*. Wrocław.
- Goovaerts, L., De Cock, M., Struyven, K. and Dehaene, W. A concrete proposal to introduce control theory to 16 year old pupils. Submitted.
- He, Q. P., Wang, J., Zhang, R., Johnson, D., Knight, A. and Polala, R. (2016). A modular approach to integrating biofuels education into chemical engineering curriculum: Part I—learning materials. *Chemical Engineering Education*, 50(2), 98–106.
- Heil, D., Pearson, G. and Burger, S. (2013). *Understanding integrated stem education: Report on a national study*. Atlanta. American Society for Engineering Education.
- Huntley, M. A. (1998). Design and implementation of a framework for defining integrated mathematics and science education. *School Science and Mathematics*, 98(6), 320–327. <https://doi.org/10.1111/j.1949-8594.1998.tb17427.x>
- Isik, D. and Tarm, K. (2009). The effects of the cooperative learning method supported by multiple intelligence theory on Turkish elementary students mathematics achievement. *Asia Pacific Education Review*, 10(4), 465. <https://doi.org/10.1007/s12564-009-9049-5>
- James, R. K., Lamb, C. E., Householder, D. L. and Bailey, M. A. (2000). Integrating science, mathematics and technology in middle school technology-rich environments: A study of implementation and change. *School Science and Mathematics*, 100(1), 27–35. <https://doi.org/10.1111/j.1949-8594.2000.tb17317.x>
- Jasien, P. G. and Oberem, G. E. (2002). Understanding of elementary concepts in heat and temperature among college students and k-12 teachers. *J. Chem. Educ.*, 79(7), 889. <https://doi.org/10.1021/ed079p889>
- Kaper, W. H. and Goedhart, M. J. (2002). ‘Forms of energy’, an intermediary language on the road to thermodynamics? Part I. *International Journal of Science Education*, 24(1), 81–95. <https://doi.org/10.1080/09500690110049114>
- Kelley, T. R. and Knowles, J. G. (2016). A conceptual framework for integrated stem education. *International Journal of STEM Education*, 3(1), 1–11. <https://doi.org/10.1186/s40594-016-0046-z>
- Klein, S. S. and Sherwood, R. D. (2005). Biomedical engineering and cognitive science as the basis for secondary science curriculum development: a three year study. *School Science and Mathematics*, 105(8), 384–401. <https://doi.org/10.1111/j.1949-8594.2005.tb18059.x>
- Lam, P., Doverspike, D., Zhao, J., Zhe, J. and Menzemer, C. (2008). An evaluation of a stem program for middle school students on learning disability related iep. *Journal of STEM Education: Innovations and Research*, 9(1/2), 21.
- Lewis, E. L. and Linn, M. C. (2003). Heat energy and temperature concepts of adolescents, adults and experts: Implications for curricular improvements. *Journal of Research in Science Teaching*, 40, S155–S175.
- Mehalik, M. M., Doppelt, Y. and Schuun, C. D. (2008). Middle-school science through design-based learning versus scripted inquiry: Better overall science concept learning and equity gap reduction. *Journal of Engineering Education*, 97(1), 71–85. <https://doi.org/10.1002/j.2168-9830.2008.tb00955.x>
- Papadouris, N., Constantinou, C. P. and Kyratsi, T. (2008). Students’ use of the energy model to account for changes in physical systems. *Journal of Research in science teaching*, 45(4), 444–469. <https://doi.org/10.1002/tea.20235>
- Perkins, D. N. and Salomon, G. (1988). Teaching for transfer. *Educational leadership*, 46(1), 22–32.



- Ríordáin, M. N., Johnston, J. and Walshe, G. (2016). Making mathematics and science integration happen: key aspects of practice. *International Journal of Mathematical Education in Science and Technology*, 47(2), 233–255. <https://doi.org/10.1080/0020739X.2015.1078001>
- Ross, J. A. and Hogaboam-Gray, A. (1998). Integrating mathematics, science and technology: effects on students. *International Journal of Science Education*, 20(9), 1119–1135. <https://doi.org/10.1080/0950069980200908>
- Schnittka, C. and Bell, R. (2011). Engineering design and conceptual change in science: Addressing thermal energy and heat transfer in eighth grade. *International Journal of Science Education*, 33(13), 1861–1887.
- Schnittka, C., Bell, R. and Richards, L. (2010). Save the penguins: Teaching the science of heat transfer through engineering design. *Science Scope*, 34 (3), 82–91. <https://doi.org/10.1080/09500693.2010.529177>
- Sjøberg, S. and Schreiner, C. (2010). *The rose project: An overview and key findings*. Oslo: University of Oslo, pages 1–31.
- Sözbilir, M. (2003). A review of selected literature on students' misconceptions of heat and temperature. *Bogaaziçi University Journal of Education*, 20(1), 25–41.
- Stuckey, M., Hofstein, A., Mamlok-Naaman, R. and Eilks, I. (2013). The meaning of relevance in science education and its implications for the science curriculum. *Studies in Science Education*, 49(1), 1–34. <https://doi.org/10.1080/03057267.2013.802463>
- Thibaut, L., Ceuppens, S., De Loof, H., De Meester, J., Goovaerts, L., Struyf, A., ..., others. (2018). Integrated STEM education: A systematic review of instructional practices in secondary education. *European Journal of STEM Education*. <https://doi.org/10.20897/ejsteme/85525>
- Trumper, R. (1997). Applying conceptual conflict strategies in the learning of the energy concept. *Research in Science & Technological Education*, 15(1), 5–18. <https://doi.org/10.1080/0263514970150101>
- Van den Berghe, W. and De Martelaere, D. (2012). *Kiezen voor stem. De keuze van jongeren voor technische en wetenschappelijke studies.*, VRWI studiereeks, Brussel, (25), 18–22.
- Veretennicoff, I. and Vandewalle, J. (2015). *De STEM-leerkracht*. Brussel: KVAB Press.
- Wallin, P., Adawi, T. and Gold, J. (2016). Linking teaching and research in an undergraduate course and exploring student learning experiences. *European Journal of Engineering Education*, 1–17.
- Wicklein, R. C. and Schell, J. W. (1995). *Case studies of multidisciplinary approaches to integrating mathematics, science, & technology education*.
- Wiser, M. and Amin, T. (2001). Is heat hot? Inducing conceptual change by integrating everyday and scientific perspectives on thermal phenomena. *Learning and Instruction*, 11(4), 331–355. [https://doi.org/10.1016/S0959-4752\(00\)00036-0](https://doi.org/10.1016/S0959-4752(00)00036-0)
- Yeo, S. and Zadnik, M. (2001). Introductory thermal concept evaluation: Assessing students' understanding. *The Physics Teacher*, 39(8), 496–504. <https://doi.org/10.1119/1.1424603>



<http://www.lectitopublishing.nl>



<https://www.facebook.com/LectitoJournals/>



<https://twitter.com/lectito1>



<https://www.linkedin.com/in/lectito-journals-9a675010b/>



## The Impact of Adding Written Discourse to Six Year Olds' Mathematics Explanations within a Problem-Based Learning Unit

Nicole V. Gearing <sup>1\*</sup>, Lynn C. Hart <sup>2</sup>

<sup>1</sup> *Utah Valley University*, Orem, Utah, USA

<sup>2</sup> *Georgia State University*, Atlanta, Georgia, USA

\*Corresponding Author: [nicole.gearing@uvu.edu](mailto:nicole.gearing@uvu.edu)

**Citation:** Gearing, N. V. and Hart, L. C. (2019). The Impact of Adding Written Discourse to Six Year Olds' Mathematics Explanations within a Problem-Based Learning Unit. *European Journal of STEM Education*, 4(1), 03. <https://doi.org/10.20897/ejsteme/3952>

**Published:** April 29, 2019

### ABSTRACT

Communicating their thinking in mathematics is challenging for young children. This research studied the change in six-year old students' oral and written solution explanations before and after six problem-based mathematics lessons that focused on developing conceptual understanding of adding or subtracting a 2-digit number and a multiple of ten. Participants were assigned to a comparison group or an intervention group based on the classroom in which they were assigned. All students completed a pre-and post-assessment. Both groups received the same, six problem-based lessons. To encourage growth in their communication skills, students in both groups were asked to talk about their strategies, while the intervention group was asked to both talk and write about their strategies during each lesson. Oral and written pre-and post-assessments were scored using a rubric adapted from the Project M3 curriculum (Gavin et al., 2006-2008) and interrater reliability was established. T-test analyses were conducted to determine if a significant difference exists between first-graders oral and written mathematical explanations within discourse modes (comparing pre/post writing or pre/post talking) and between discourse modes (comparing talking and writing) for the intervention and comparison groups. A significant difference between discourse modes was found on the pre-assessments but not the post-assessments, suggesting that increasing oral discourse decreased the gap between the children in both groups ability to talk and write about their thinking. A significant difference was found within discourse modes for the intervention group, but not the comparison group, suggesting that adding written discourse to problem-based lessons further increased the children in the intervention group's ability not only to write about their solutions, but also to talk about their thinking. In order to give a glimpse of the development of the first graders in the intervention group's oral and written mathematical explanations, the work of three focus students was selected to share. Through the use of problem-based instruction and cognitively demanding tasks along with the development of sociomathematical norms and discourse knowledge, the young children in this study were able to improve their verbal and written communications skills.

**Keywords:** sociomathematical norms, social constructivism, oral discourse, written discourse, problem-based lessons

### INTRODUCTION

Reform movements around the mathematics education of students in primary grades 1-5 (approximate ages 5 to 10 years) often focus on developing children's ability to communicate their mathematical reasoning when

problem solving. While this study focused on the United States Common Core State Standards for Mathematics (2014), this shift is evidenced in numerous country's curriculum reform documents including, Sweden (2011), Finland (2014), England (2014), the Netherlands (2016), and others (Pont, 2018). Each of these revisions suggest developing children's ability to communicate mathematical reasoning when solving problems. While we acknowledge that communication is an essential part of learning in mathematics, it is often difficult for *young children* to talk (Moyer, 2000) because they may not have had rich experiences in sharing their mathematical reasoning with others. While talk and writing are not the only forms of mathematical communication, there are several benefits of incorporating these skills during mathematics lessons. Talking makes student's ideas public and it gives students the opportunity to explain and justify their thinking, further deepening their conceptual understanding of mathematical concepts (NCTM, 2000). Writing about mathematical ideas creates a written record of a child's thought process (Lee, 2006) and provides every child with the opportunity to engage in explaining their thinking, rather than only the few called upon during a class discussion. Finally, talking and writing about mathematical thinking gives teachers a better understanding of what a child knows or the misconceptions a child may have about a concept.

When building communication skills in the mathematics classroom of *very young* students, writing is often not part of the conversation. However, in the U.S. the practice standards put forth by NCTM expect children to explain the reasoning used to solve problems. The CCSSM (2010) third Standard for Mathematical Practice (SMP) expects children, beginning in Kindergarten (age 5), to be able to construct viable arguments and critique the reasoning of others. In the explanation of the standard it says, 'students at all grades can listen or read the arguments of others, decide whether they make sense, and ask useful questions to clarify or improve the arguments' (Common Core State Standards Mathematics [CCSSM] 2010, p. 2). While the standard does not explicitly require children to write about their reasoning, it can be inferred that this is an expectation by asking students to read the arguments of others. This is similar to the Department for Education National Curriculum in England for Key Stages 1 (5-7 years) and 2 (7-11 years) that states that students should be able to "**reason mathematically** by following a line of enquiry, conjecturing relationships and generalizations, and developing an argument, justification or proof using mathematical language" (Department for Education, 2013, p. 3). Additionally, since the focus of mathematics for young children has often been computation, students frequently learn to compute without making sense of the procedures they use, leading to an inability to apply procedures to solve real world problems (National Research Council, 2000). Being able to reason mathematically and communicate mathematical thinking both orally and in writing about procedural and conceptual knowledge clearly have become vital skills for children to acquire as they move into the 21<sup>st</sup> century workforce (Boaler, 2016).

With changes in standards come changes in assessment. If standards are addressing the need to communicate mathematical thinking, this skill must be assessed. One way for teachers to assess understanding in their classrooms is through the use of oral discourse; however, this can be particularly difficult when teachers have twenty plus children in their class. Achievement tests frequently rely on multiple-choice items, making it challenging to assess a child's ability to construct a viable argument or critique the reasoning of others. As is evident, explaining one's thinking cannot reasonably be evaluated through use of many traditional assessments. As a result, constructed response items requiring written explanations are being added to some assessments such as the Partnership for Assessment of Readiness for College and Careers (PAARC) (2016) in the U.S., creating a need to develop students' ability to also explain their mathematical reasoning through writing.

## THEORETICAL PERSPECTIVES

### Social Constructivism

Smith and Stein (2015) make the following comment about U.S. schools:

The instructional practices used in the majority of our nation's classrooms will not prepare students for new demands. National studies have shown that American students are not routinely asked to engage in conceptual thinking or complex problem solving (Stigler and Hiebert, 1999) . . . It is unrealistic to expect students to learn to grapple with the unstructured, messy challenges of today's world if they are forced to sit silently in rows, complete basic skills worksheets, and engage in teacher-led discussions . . ." (p. 1)

Fortunately, methods for teaching and learning mathematics are changing, with a primary influence being the commonly accepted theoretical perspective of social constructivism, which suggests that learners must construct their own knowledge (Ernest, 2008). And, as suggested above, mathematical understanding and reasoning is not only constructed within an individual, it is also socially constructed, through conversations and discourse, a key component needed for intellectual growth (Tharp and Gallimore, 1991).

## Mathematical Discourse

The importance of developing spoken language in mathematics is recognized internationally. In England the Department for Education (2013) states in their Key Stage 1 curriculum, “The quality and variety of language that pupils hear and speak are key factors in developing their mathematical vocabulary and presenting a mathematical justification, argument or proof.” In the U.S. the NCTM (2015) points out that spoken language “gives students opportunities to share ideas and clarify understandings and construct convincing arguments regarding why and how things work . . .” (p. 29). Key features of mathematical discourse include special key words, unique visual mediators, distinctive routines, and generally endorsed narratives (Sfard, 2012). However, with young children, mathematical discourse is often limited to oral exchanges. There are some research-based benefits to including written discourse in instruction.

The most immediate benefit is the need to help children communicate their mathematical thinking through writing for the purpose of assessment. However, the benefits of writing in the mathematics classroom go beyond preparing for the test. The act of writing encourages children to reflect on the mathematics they have learned and actively engage in thinking about mathematical experiences (Burns, 2004). For example, Pugalee (2004) found that the process of writing helped high school students consolidate their thinking and develop metacognitive awareness. Bicer et al. (2013) found that for middle school students writing acted a mediator in the problem-solving process. The National Council for Teachers of Mathematics (2000) recognizes that writing helps students consolidate their thinking. Further, writings children create serve as a record of mathematical thought (Lee, 2006) that can demonstrate student growth and understanding. Unfortunately, limited research has been done involving oral or written discourse in very young children.

The use of oral and written discourse also promotes equity in the mathematics classroom. Engaging in mathematics through speaking creates a space where students begin to take ownership of what they are learning by sharing with their peers. When students share their solution strategies and reasoning, the gap between students who understand the concept and those who do not understand the concept is reduced (Boaler, 2016). Additionally, giving students the opportunity to participate in discourse provides the teacher insight as to which students have a solid understanding of a mathematical concept and which students have misconceptions (Yackel and Cobb, 1996). Understanding a student’s thought process helps the teacher evaluate what the child knows or does not know, in turn helping the teacher improve access and equity within the classroom (Yackel, 1995). Giving children the opportunity to write about their solution strategy affords the teacher the opportunity to understand the thinking of more students than the few who are able to orally share their solution strategies during a typical lesson.

## An Expanded View of Discourse

Communication, within the context of mathematics classrooms should not be limited to oral exchanges. This is supported in the U.S. by the NCTM (2015). They state, ‘mathematical discourse includes the purposeful exchange of ideas through classroom discussion, as well as through other forms of verbal, visual and written communication’ (p. 29). In the U.K. at Key Stages 1 and 2 they introduce the notion of students reading and spelling mathematical vocabulary, “at a level consistent with their increasing word reading and spelling knowledge.” Utilizing visual, written communication in young children’s classrooms creates a record of children’s mathematical thinking (Lee, 2006) that can be used to evaluate growth over time and provides another avenue for communication and is a valuable form of discourse in the classroom.

Casa and colleagues (2016) define writing mathematically as writings that “engage students in reasoning” (p. 3). They identify four types of mathematical writing including exploratory, informative/explanatory, argumentative, and mathematically creative. Because this study sought to help children develop their ability to explain their thinking, informative or explanatory writing was used. However, it is clear there are several ways to incorporate writing within the mathematics classroom.

Understanding how to write within a certain genre is referred to as *discourse knowledge* in literacy (Olinghouse and Graham, 2009). When young children begin to learn to write in a new genre or discipline such as mathematics, they must learn the expectations of that discipline. Several intervention studies have demonstrated that actually *teaching* discourse knowledge, what the expectations are for that discipline, can enhance writing performance (e.g., Fitzgerald and Danielham, 1987). Using specific mathematical vocabulary (using *add* instead of *put together*), distinguishing between strategies (counting by ones vs. counting by tens), or knowing how to demonstrate a proof (using concrete materials or drawing models) are all discipline specific or discourse knowledge needed for communication in mathematics. Since many young children are not exposed to writing about their mathematical reasoning, this discourse knowledge must be taught and developed. Casa (2015) suggests connecting children’s oral discourse to written discourse to build a foundation for this discourse knowledge. However, many children lack the ability to use oral language to talk about their thinking in meaningful ways. This is supported by the work of Mercer and colleagues (1999). In this study, Mercer and colleagues worked with teachers in a specialized program to help their 9-10 year old students develop awareness of language as they talk with peers through collaboration.

He found a noticeable shift in the children's language, confirming the importance of explicitly teaching children how to effectively use language. More recently, Mannion and Mercer (2016) worked with older children (grades 7-9) in a Learning to Learn (L2L) project that embedded 'exploratory talk' and 'reflective journals' as two components in a project aimed at developing children as learners across disciplines. Although L2L had several other components and enhanced subject attainment cannot be attributed solely to these two components, the model as a whole helped older students to speak, listen, and reason more effectively. More specifically to mathematics instruction, Williams and Casa (2015) encouraged first graders to discuss the symmetry of a leaf, putting their ideas in what they refer to as a "talk frame." The children were then asked to go back to their seats and write about whether or not a leaf was symmetrical. The researchers expected the students to copy the ideas discussed as a whole group, however, most children connected the ideas they heard while participating in a class discussion with their own thinking, demonstrating that, with support, very young children are able to explain their thinking in writing.

## THE STUDY

Given the importance of oral and written discourse for young children, a project was conducted in four grade 1 classrooms (6 year olds) in a Title 1 school (a school with a high number of children from low socioeconomic families) in a large metropolitan school district in the southern U.S. to look at the benefits of adding written discourse to oral discourse within lessons that took a conceptually based instructional approach. The purpose of the study was to explore first-grade children's ability to talk and write about their mathematical thinking within the context of problem-based lessons. All four first-grade classrooms at the school participated in a set of six problem-based lessons taught by the first author. Problem-based lessons require students to engage in higher cognitive demand tasks, allow for varied solution strategies, which often elicits more mathematical discourse (Stein et al., 2008). Each of the four classrooms were randomly assigned to a comparison group or an intervention group. Both groups of students (comparison and intervention) participated in problem-based lessons rich in oral discourse that focused on adding and subtracting two-digit numbers and multiples of ten. The intervention group also wrote about how they solved problems during each lesson. Pre/post written and oral mathematical explanations were collected at the beginning and completion of a six-lesson problem-based unit in the numbers and operations domain.

### Participants and Context

While all students in the classrooms participated in the problem-based lessons, pre and post assessments were only analyzed for students with parental consent ( $n = 50$ ). See [Table 1](#) for detailed participant demographics. The teachers of the students included four female teachers, three African-American and one Caucasian. The two comparison teachers were African American. One Intervention teacher was African American while the other was Caucasian.

**Table 1.** Participant Demographics

	Comparison Group	Intervention Group
Number of Participants	23	27
Male	7	13
Female	16	14
IEP	4	2
Struggling Math Learners	3	5
English Language Learners	2	7
Gifted	2	2

The school's mathematics curriculum was Eureka Math. Eureka Math is a widely utilized K-12 mathematics curriculum used in the U.S. It aligns with the Common Core State Standards and is free for use in schools (Great Minds, 2016). Each Eureka lesson contains the same lesson structure: fluency practice, application problem, concept development, and 10 minutes for student debrief. During the time of this study the first-grade teachers were asked to proceed through the Eureka Math Module lessons four days a week. Students participated in the problem-based lessons with the researcher the remaining day. The present study focused on base-ten addition and subtraction, the mathematics unit occurring on the other four days was a unit on Geometry. While the students were focusing on Geometry during the study, they had previously focused on base-ten addition and subtraction in the fourth Eureka unit. Topics in that unit, module 4, had included tens and ones, comparison of two-digit numbers, addition and subtraction of tens, addition of tens or ones to a two-digit number, varied problems within 20, addition of tens and ones to a two-digit number. Within that module, students were presented with the strategy of direct modeling counting on, single-digit sums, and add ones and ones or tens and tens.

## METHODS

### Data Collection

Prior to beginning data collection, the researcher observed a mathematics lesson in each classroom to develop a picture of a typical lesson and what, if any, sociomathematical norms had been developed. The researcher also conducted a 30-minute interview with each of the teachers, asking about how her students typically talk and write in mathematics class. Subsequently students in all four classes completed an oral and written pre-assessment. The written assessment consisted of presenting each class with an Add To: Result Unknown problem (CCSSM, 2010). Students were asked to solve the problem and then write a note to the teacher telling her how they solved the problem. The oral pre-assessment was done individually. Students were asked to solve a different Add To: Result Unknown problem. They were then asked to tell the researcher orally how they got the answer by answering the question, “Can you tell me how you got your answer?”. The problems for the pre and post assessments can be found in [Table 2](#). Each response was recorded and transcribed. The pre-assessment was followed by each class participating in a 6-lesson problem-based unit. At the completion of the unit, students participated in the same written and oral assessments with new problems.

**Table 2.** Assessment Problems

Assessment	Problem
Pre-Oral	Skylar had 32 balloons for her birthday. She blew up 30 more balloons. How many balloons does Skylar have now?
Pre-Written	Mrs. Smith had 28 pencils for the class. She found 30 more pencils. How many pencils does Mrs. Smith have now?
Post-Oral	Joe had 26 rocks in his collection. He went on a walk and found 40 more. How many rocks does Joe have now?
Post-Written	Eric had 36 cookies for a class party. He baked 40 more cookies. How many cookies does Eric have now?

### The Intervention

Although students in this study previously had lessons on how to add two-digit numbers, pre-assessment results indicated that most students were not able to explain how they solved problems with detail, often saying “I just knew” or “I added”. Therefore, an important emphasis in all the classrooms during the 6-lesson unit, was to cultivate highly developed sociomathematical norms, which refers specifically to the norms developed in the mathematics classroom. This was important since often children have a difficult time explaining their thinking because they are unsure what it means to explain (Levenson, 2013). Intentionally focusing on language norms was supported by Mercer et al. (1999) who found that explicitly teaching children how to use language to reason and when working collaboratively with peers showed an improvement in their oral communication.

Sociomathematical norms are “distinct from general classroom social norms in that they are specific to the mathematical aspects of students’ activity” (Yackel and Cobb, 1996, p. 458). During all the lessons, an effort was made to help the students develop a shared understanding of what a meaningful explanation constitutes (Yackel and Cobb, 1996). When shared understandings are established, learning occurs as children share how they solved problems and their peers make sense of their mathematical reasoning. Children also make judgments about the similarities and differences in the solution strategies shared and feel comfortable questioning and challenging the thinking of their peers (Yackel, 1995).

While sociomathematical norms usually refer to oral discourse within a mathematics classroom, these norms can also be established when children are sharing their explanations through written discourse. Therefore, the same conversations used to develop sociomathematical norms for talking about mathematical thinking were used to develop children’s written responses. In the classrooms of this study, developing norms included what it meant to *explain* how you solved a problem to peers and the class. As mentioned, student explanations at the beginning of the unit often were limited to “I just knew” or “I just added the two numbers together.” However, in a classroom where clear sociomathematical norms are developed, what counts as a sufficient explanation is clear to the group, and peers understand exactly what the student did to solve the problem.

To develop and encourage more specific explanations the researcher asked questions such as, “What did you do to add the two numbers together?” or “How did you add the two numbers together?” Through these conversations, the students began to include these ideas in their own explanations both with their peers and when they were selected to share with the class. For example, in the third lesson in the unit the students investigated the number of Pringles used to make a Pringle Ringle (stacking Pringle chips in a circular fashion) (Fletcher, 2016). The problem they solved was, *There are 78 Pringles in a stack. Some were used to make a Pringle Ringle. Now there are 20 left in the stack. How many Pringles are in the Pringle Ringle?* In one class the researcher asked Daniel to explain his strategy. He responded, “I drew 78 and then I crossed out 20 and then I counted the rest and I got 58.” Before assuming a particular method for drawing 78, the researcher asked, “How did you draw your 78 Pringles?” He responded, “I drew 78 ones.” The researcher proceeded to draw 78 Pringles on the board. As she drew the 78 Pringles some of the students were commenting, “Can’t you just make tens?” and “I can do that faster with some



tens and ones.” The researcher asked the students to hold on to their thoughts, reminding them that Daniel was sharing his strategy and he did not use tens and ones. While the researcher was encouraged that students saw a more efficient way of solving the problem, she reminded the students that Daniel was telling us exactly what *he did* to solve the problem. By reinforcing and honoring an explanation that mirrored exactly the strategy the student had used, other students began to understand what it meant to explain how they solved the problem and how to differentiate strategies. Once the researcher finished drawing and crossing out 20, she asked Daniel, “How did you know the answer was 58?” Daniel replied with a huge grin, “I counted by ones.” Clearly proud that his strategy had been honored, Daniel was able to explain that he drew all of the Pringles, crossed 20 out and counted the remaining. While more efficient strategies emerged in later discussions, focusing on unpacking exactly what the student had done was critical in developing the sociomathematical norms of the class and in modeling what it meant to show or explain your strategy. After conversations such as this, students began including how they counted in their oral and written explanations.

Interestingly, Daniel repeated his same, direct model, count by ones strategy the following week. In this lesson, the children were adding  $40 + 47$ . When the researcher asked him why he drew out  $40 + 40$  by ones, he responded, “I didn’t know how to draw what I did. I had my answer by the time I got to my seat.” The researcher asked him to explain how he knew the answer. He said, “I knew that  $40 + 40 = 80$  and 7 more equals 87, but I didn’t know what to write on my paper.” Daniel mentally used a more sophisticated solution strategy than counting all, however, he was unsure how to write his thinking on paper, likely because he was the first student to mention the use of an invented algorithm and had no previous experience to relate to. Therefore, the researcher/teacher selected him to share so that she might help Daniel and the other students in a similar predicament decide how to translate their mental math solutions to paper.

### Data Analysis

Pre and post student assessments were scored by two independent scorers who were trained using the rubric in Appendix A. The rubric was adapted from Gavin et al. (2006-2008), Rubric for Student Mathematician’s Journal, by the first and second authors. A student could receive a score of 0-3 on each assessment. Group mean scores were calculated for each of the 8 assessments, i.e. pre and post written and oral results for both the intervention and the comparison group. Quantitative results are shared next, followed by qualitative analysis of three focus children’s assessments.

## RESULTS

### Quantitative Rubric Results

In order to determine if there was a significant difference between all the children’s oral and written mathematical explanations before and after the problem-based lessons, paired-sample t-tests were conducted to determine differences in the children’s oral and written mathematical explanations before and after the problem-based lessons. Because more than one t-test was conducted using the same set of data, the Bonferroni Method was used to determine the alpha level to avoid a type I error, falsely finding significant results (Armstrong, 2014). Since eight t-tests were conducted (see [Table 3](#) and [4](#)), an alpha level of .006 was used to determine significance for each t-test. Effect size was also calculated and reported for each t-test using G\*Power 3.1 (Faul et al., 2009). Effect size is reported to communicate the size of the effect of results (Wright, 2003). Cohen (1988) interprets an effect size around .2 as small, .5 as moderate, and .8 as large. The greater the effect size, the more practical significance of the results.

### Comparing Within-Group Means between Discourse Modes

A paired-sample t-test was conducted to compare the mean oral and mean written scores of the comparison group and of the intervention group prior to the problem-based lessons (See [Table 3](#)). These results suggest that prior to the problem-based lessons, there was a significant difference within both group’s ability to explain their mathematical thinking using oral language versus their ability to explain their thinking using written language.

Paired-sample t-tests were again conducted to compare the within-group mean oral and written scores of the students in the comparison and the students in the intervention groups at the completion of the problem-based lessons (See [Table 3](#)). The post results showed no significant difference in the mean scores of students from both groups on the oral and written explanations assessment. However, there was less difference between the intervention group’s oral and written scores than the comparison groups oral and written scores. More simply, the gap between the written and oral results was reduced more in the intervention group.

**Table 3.** Results of t-test and Descriptive Statistics for Comparing between Discourse Modes (Pre/Post)

Group	Language Mode						Difference		
	Oral			Written			<i>df</i>	<i>t</i>	Cohen's <i>d</i>
	<i>M</i>	<i>SD</i>	<i>n</i>	<i>M</i>	<i>SD</i>	<i>n</i>			
Pre-Comparison	5.43	2.50	23	3.48	2.25	23	22	4.8914*	.60
Pre-Intervention	4.85	2.33	27	3.37	2.31	27	27	3.9507*	.46
Post Comparison	5.62	2.50	21	4.67	2.61	21	20	2.3271	.27
Post Intervention	6.36	1.87	25	6.04	2.14	26	24	0.8382	.11

\**p* < .006**Table 4.** Results of t-test and Descriptive Statistics for Oral and Written Explanation Scores

Group	Time						Difference		
	Pre			Post			<i>df</i>	<i>t</i>	Cohen's <i>d</i>
	<i>M</i>	<i>SD</i>	<i>n</i>	<i>M</i>	<i>SD</i>	<i>n</i>			
Oral Comparison	5.43	2.50	23	5.62	2.50	23	20	0.8667	.06
Oral Intervention	4.85	2.33	27	6.36	1.87	25	24	4.1167*	.50
Written Comparison	3.48	2.52	23	4.67	2.61	21	20	1.8199	.34
Written Intervention	3.37	2.31	27	6.04	2.14	26	25	5.2021*	.87

\**p* < .006

### Comparing within group means within Discourse Modes

Paired-sample t-tests were conducted to compare the mean oral explanation scores each group received before and after the problem-based lessons (See [Table 4](#)). These results suggest that adding writing to problem-based lessons may increase students' ability to explain their mathematical thinking orally.

Paired-sample t-tests were also conducted to compare the mean written explanation scores each group received before and after the problem-based lessons (See [Table 4](#)). Not surprisingly, these results suggest that adding writing to an instructional problem-based unit may increase student's ability to communicate their thinking in writing in a short 6-week period of time. Further, we found that simply engaging in problem-based lessons where oral discourse is used as a medium to explain mathematical thinking was not enough to produce more detailed written explanations among the children in the comparison group.

The results from these analyses indicated that when adding writing to problem-based instruction, children are better able to both talk and write about their mathematical thinking. However, these quantitative results provide a limited picture of the nature of the change seen in the children's ability to engage in written and oral discourse. Therefore, qualitative analyses of a purposefully selected focus children are shared and discussed here.

### Qualitative Focus Children Examples

Focus Child Pre-Assessment Results. In order to give a glimpse of the development of the first graders in the intervention group's oral and written mathematical explanations, the work of three focus students were selected to share. The students were selected to demonstrate a range of ability before the unit and growth at the completion of the unit.

#### Focus Student 1: Maria

Maria, an English as a Second Language Learner, was chosen as her responses on the pre-assessment were typical of her peers, that is, they were vague, did not demonstrate conceptual understanding, and lacked the use of formal and/or informal mathematical vocabulary. Like many of her peers in this context, Maria struggled with the mathematics content as well as with her ability to communicate her thinking orally or in writing prior to the problem-based unit.

Maria's pre-assessment oral explanation transcription is seen in [Figure 1](#). As is evident, her account lacks detail. While it suggests that she thinks that the two numbers should be added together by her use of the word 'plus', there is no description of how she reached her incorrect solution. She only shares that she just knew the answer because she was 'thinking in her head.' From both her representation and explanation, a teacher could not determine how Maria came to 42 as her solution.

Maria's pre-assessment written explanation is seen in [Figure 2](#). Like many of her peers, she shared less about her solution strategy when asked to write about it; but, similar to her oral explanation, her written explanation reveals her difficulty with the mathematical concept of adding tens and ones as well as her inability to communicate what she did to solve the problem. From her explanation, we are unable to determine how Maria came to a solution of 38. Note that Maria was asked to translate her invented spelling when necessary.

Skylar had 32 balloons for her birthday. She blew up 30 more balloons. How many balloons does Skylar have now?

Use numbers or pictures to find the solution to the story

$$32 + 30 = 42$$

Solution: \_\_\_\_\_

I was thinking in my head and I just knew it.  
Because 32 plus 30 equals 42.

Figure 1. Maria's Oral Pre-Assessment

Mrs. Smith had 28 pencils for the class. She found 30 more pencils. How many pencils does Mrs. Smith have now?

Use numbers or pictures to find the solution to the story

$$28 + 30 = 38$$

Solution: \_\_\_\_\_

Use words to explain how you found your solution:

I <sup>(got)</sup> goni be~~ca~~us I <sup>(knew)</sup> h~~ea~~o it.

Figure 2. Maria's Written Pre-Assessment

**Focus Student 2: Paris**

Paris is a gifted student. Her teacher explained that she is an excellent math student but like many of her peers, often has a difficult time explaining how she solved problems. This could be because she solves problems so



quickly that she is not metacognitively aware of their solution strategies, or because she is not sure what is expected of her when she is asked the question, “Can you tell me how you got your answer?”

On the oral pre-assessment (Figure 3), Paris interpreted the problem as subtraction rather than addition, however her math is consistent with her interpretation. When asked about why she subtracted, she explained the balloons blew up and when things blow up they are gone, so she subtracted. She also drew a thorough picture, demonstrating conceptual understanding, but when asked to explain her thinking, she simply replied, “a picture.”

Skylar had 32 balloons for her birthday. She blew up 30 more balloons. How many balloons does Skylar have now?

Use numbers or pictures to find the solution to the story

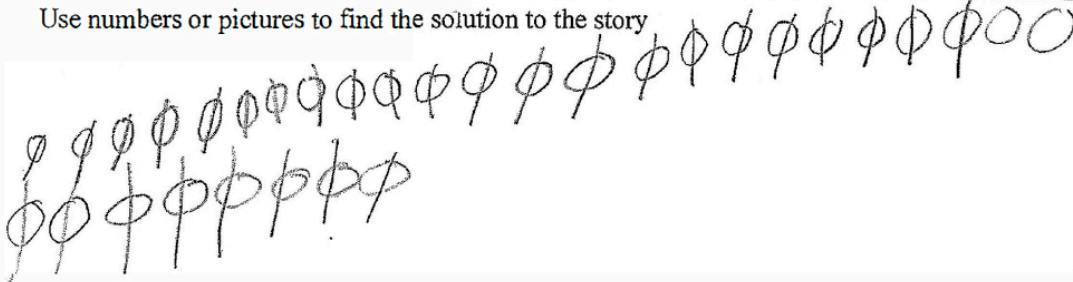

Solution:  $32 - 30 = 2$

A picture

Figure 3. Paris’ Oral Pre-Assessment

Paris’ written pre-assessment (Figure 4) had similar results to her oral response, simply stating, “I use blocks.” While it is clear from her visual representation that Paris has conceptual understanding of the mathematics, she was unable to explain what she did to solve the problem in writing.

Mrs. Smith had 28 pencils for the class. She found 30 more pencils. How many pencils does Mrs. Smith have now?

Use numbers or pictures to find the solution to the story



$28 + 30 = 58$

Solution:  $58$

Use words to explain how you found your solution:

I use blocks.

Figure 4. Paris’ Written Pre-Assessment

**Focus Student 3: Daniel**

Daniel was selected as the third focus student because while his oral response contained more detail than many of his peers, his written response does not explain how he solved the problem. Many students who were able to clearly talk about their solution strategy, were not able to do the same thing in writing. This suggests the importance of developing discourse knowledge within the mathematics classroom to help students understand what is expected in this genre of writing.

On the oral pre-assessment (Figure 5), Daniel clearly describes that 30 plus 30 is 60 and 2 more is 62. However, his response does not explain where 30 and 30 come from or why he added two more to 60. This was a common response among the children who were more clearly able to communicate verbally what they did to solve the problem.

Skylar had 32 balloons for her birthday. She blew up 30 more balloons.  
How many balloons does Skylar have now?

Use numbers or pictures to find the solution to the story

Solution: 62

I solved my answer because I counted three plus three and then I added two more and that equals sixty-two.

**Figure 5.** Daniel's Oral Pre-Assessment

Daniel's written pre-assessment (Figure 6) was very different from his oral pre-assessment. His response includes the number sentence used to solve the problem but does not explain how the solution was found. Further, Daniel's representation for this problem is very different than the representation he used on the oral pre-assessment. As described earlier, Daniel did not know how to explain his invented algorithms in writing.

**Focus Children Post-Assessment Results****Focus Child One: Maria**

Like her peers, Maria's oral explanation post-assessment (Figure 7) demonstrates improvement in her ability to explain her mathematical thinking. Although she has the incorrect solution written in her picture, she gives the correct solution at the end in her oral explanation and she is able to explain how she solved the problem, providing a teacher with insights into understandings and/or misunderstandings Maria may have.

Maria's words show that while she is mixing metaphors, that is, 'I was thinking 40 and 2 tens' rather than saying either 40 and 20 or 4 tens and 2 tens, she realizes those two quantities need to be combined. She goes on to say, 'and then I add.' At this point her choice of words is confusing but she says she needs to "take away the 6", suggesting that the six is not connected to her first step of combining the 40 and 2 tens. By taking the 6 away she can combine the 40 and 2 tens and 'you get 60'. She goes on to say that you then need to 'add the 6 back and you get 66'. Though her response is slightly difficult to follow, she clearly has some understanding of the tens and ones and how to combine them. Contrast this to her pre-assessment explanation, "I was thinking in my head and I just knew it. Because  $32 + 30 = 42$ ." which provides no insights into her thinking.

Mrs. Smith had 28 pencils for the class. She found 30 more pencils.  
How many pencils does Mrs. Smith have now?

Use numbers or pictures to find the solution to the story.

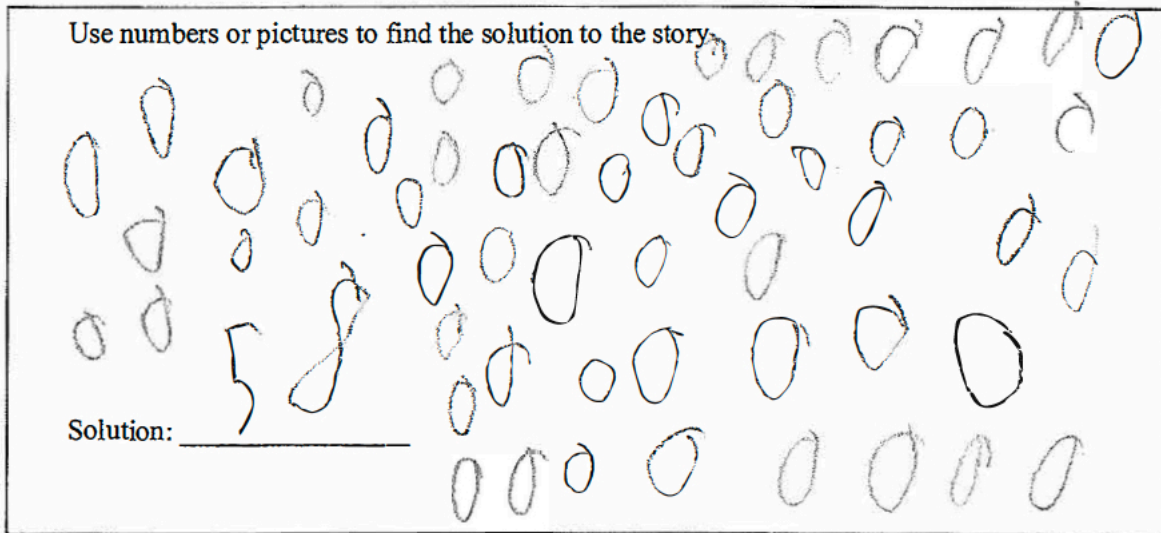

Solution: \_\_\_\_\_

Use words to explain how you found your solution:

It is 28 + 30 = 58

Figure 6. Daniel's Written Pre-Assessment

Joe had 26 rocks in his collection. He went on a walk and found 40 more. How many rocks does Joe have now?

Use numbers or pictures to find the solution to the story

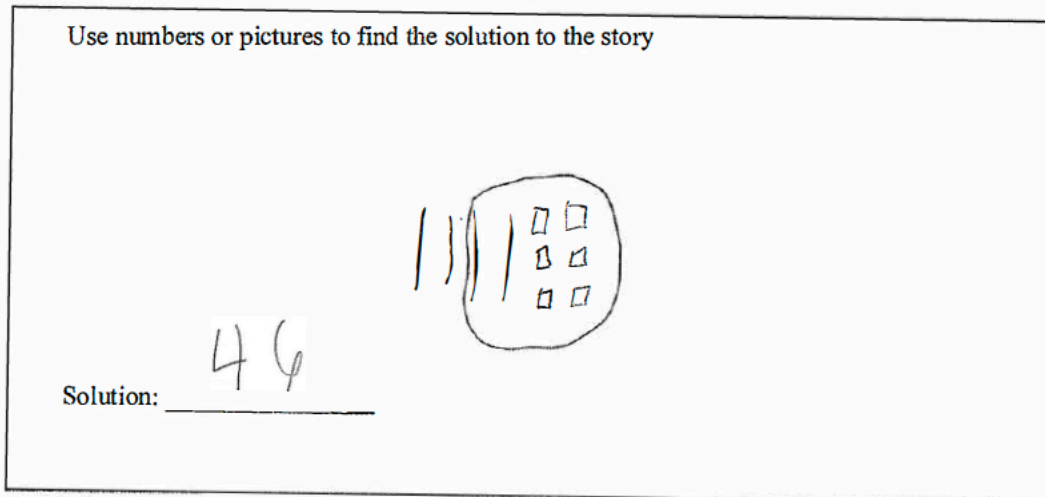

Solution: \_\_\_\_\_

I was thinking that 40 and 2 tens and then 6 ones and I add 2 more take away the 6 and you get 60 and then you add the 6 back and you get 66.

Figure 7. Maria's Post Oral Assessment

Her written response (Figure 8) demonstrates the beginning of a conceptual understanding of base ten and how combining tens and combining ones can be used in addition. Also, important to note that invented spelling often used by young children need not necessarily limit their ability to communicate their thinking.

Eric had 36 cookies for a class party. He baked 40 more cookies. How many cookies does Eric have now?

Use numbers or pictures to find the solution to the story

Solution: \_\_\_\_\_

Use words to explain how you found your solution:

I got 76 Bckys put 3 10  
 ten and put 6 1 ten and  
 put 4 10 to get ten put  
 all to get = 76.

Figure 8. Maria's Post Written Assessment

Joe had 26 rocks in his collection. He went on a walk and found 40 more. How many rocks does Joe have now?

Use numbers or pictures to find the solution to the story

Solution: \_\_\_\_\_

I did tens and ones. First I counted the tens and then I count the ones.

Figure 9. Paris' Post Oral Assessment



**Focus Child 2: Paris**

Paris' oral post-assessment (Figure 9) demonstrates a more detailed response, though still somewhat vague. Unlike the pre-assessment she includes the use of mathematical vocabulary such as tens, ones, and count. Through her representation, the reader can determine that she does have conceptual understanding of the mathematics, however, her oral explanation does not indicate how many tens and ones she counted.

Paris' written post-assessment [Figure 10] is much more descriptive than her pre-assessment. She demonstrates through her words an awareness of adding tens to tens and ones to ones, however, she confuses 40 tens for 4 tens. This was a common error noticed throughout the unit.

Eric had 36 cookies for a class party. He baked 40 more cookies.  
How many cookies does Eric have now?

Use numbers or pictures to find the solution to the story

Solution: \_\_\_\_\_  $36 + 40 = 76$

Use words to explain how you found your solution:  
 I started with 36 then I got 40  
 tens out then I counted 3 tens and  
 40 tens then I had 6 left and I counted  
 that then I got 76.  
 It was fun!

Figure 10. Paris' Post Written Assessment

**Focus Child 3: Daniel**

Though Daniel's pre-assessment included more detail than many of his peers, his post-assessment included even more information about how he solved the problem. On the pre-assessment he explains that he added 30 and 30 and then the 2 more. On the post-assessment, he explains that he knows  $2 + 4$  is 6 then  $20 + 40 = 60$ . His next sentence is a bit confusing, he says "then I put  $26 + 40$  equals 66." While he demonstrates an understanding of adding tens to tens, his statement about  $26 + 40$  equals 66 does not explain where he came up with the six ones in 66. Towards the end of the unit, many of the children began using invented algorithms to solve problems and were working towards explaining their strategies. Conversations with Daniel and others using similar strategies revealed that they were adding the tens together,  $20 + 40 = 60$ , so they knew that  $26 + 40 = 66$ . More time to develop sociomathematical norms for explaining invented algorithms would have likely helped him become clearer about his strategy.

Joe had 26 rocks in his collection. He went on a walk and found 40 more. How many rocks does Joe have now?

Use numbers or pictures to find the solution to the story

$$20 + 40 = 60$$

Solution: 66

What I did 2 plus 4 and then 40 plus 20 equals 60 then I put 26 plus 40 equals 66.

Figure 11. Daniel's Post Oral Assessment

Daniel's written post-assessment (Figure 12) also contains more detail than his pre-assessment. His response includes the use of number sentences rather than writing out the words. Because he is in first grade and beginning to explore writing about his thinking, number sentences were expected, therefore, his use of a plus sign and equal sign were considered as using mathematical vocabulary. While his response is more detailed, it contains some errors. He writes that he did  $30 + 4 = 70$ . Here he likely confused 4 tens with 40 while writing, a common error among the students throughout the unit. He then writes  $70 + 6 = 76$ . While his explanation explains exactly what he did to solve the problem, he does not use a linking verb to link the two number sentences for the reader.

Eric had 36 cookies for a class party. He baked 40 more cookies. How many cookies does Eric have now?

Use numbers or pictures to find the solution to the story

Solution: 76

Use words to explain how you found your solution:

$30 + 4 = 70$        $70 + 6 = 76$

30 I did  $3 + 4 = 7$  that

is the end.

Figure 12. Daniel's Post Written Assessment

## DISCUSSION AND LIMITATIONS

While children are not expected to write about their mathematical reasoning until the third grade in the U.S. (CCSSELA, 2010), the results of this study suggest a value of adding written discourse to problem-based mathematics instruction in young children's classrooms. The findings can be partially attributed to the development of sociomathematical norms in the classrooms. Focusing on sociomathematical norms, i.e., what is an acceptable, detailed, and understandable explanation of a strategy that was used, enhanced the children in this study's ability to express their thinking orally (Yackel and Cobb, 1996) and in writing. Interestingly, interviews with the teachers prior to the unit revealed that the teachers believed norms for explaining mathematical thinking orally had already been established within each classroom. For example, in the interview with Paris' teacher, she indicated that students were often encouraged to share their solution strategies with the class. When asked *how* children would talk about their solution strategies, she explained giving a rather sophisticated example, "They might say I knew that  $8 + 8 = 16$ , so I know  $8 + 7 = 15$ . Or if there were a 2-digit number plus a 2-digit number they might say well I know 25 has 2 tens and 13 has 1 ten so I knew it was going to have to be 30 something so I added the tens and I added the ones." However, during the unit none of the children in her class responded in this way when explaining how they solved a problem on the pre-assessment, suggesting a disconnect between the children's actual ability to explain their thinking and the teacher's expectations. Additionally, as seen in the student pre-assessment examples, students were at differing levels of development of communicating their thinking, suggesting that what qualified as a clear explanation was not universally developed by the children (Levenson et al., 2009). A few of the children, like Daniel, were explicit in their thinking on the oral pre-assessment explaining that 30 plus 30 equals 60 and plus 2 equals 62, while more typically, others like Paris stated simply they used "a picture." While Paris' response is generic, her written representation demonstrates that she understood the mathematics, she may not have understood exactly what was expected when she was asked, "Can you tell me how you got your answer?" A question such as that often leaves children struggling to comprehend what is expected when they are asked to explain how they found their solution. Therefore, during each lesson of the unit in this study, it was critical that the researcher had explicit conversations with the students about what was an acceptable explanation that could be understood by members of the class, including describing exactly what they did and the steps they took. The need for explicit instruction is consistent with earlier research by Mercer et al. (1999) who found that with 9-10 year olds the use of clear and precise discussions regarding talking with peers about their ideas helped children monitor their thinking and communicate it verbally.

It was also central in the lessons in this study to focus on developing the discourse knowledge specific to the mathematics classroom (McClain and Cobb, 2001). There needed to be intentional attention on the language and vocabulary of mathematics, such as using *add* instead of *put together*, to bring further clarity to the written and oral explanations. As demonstrated in Maria's work, at the beginning of the unit most of the children wrote explanations such as, *because I knew in my head, I counted, or I drew a picture*. By the end of the unit their explanations were more developed, more clearly describing the steps actually taken to find the solution, even when if it were not correct. This development in written explanations can be attributed, at least in part, to the development of discourse knowledge, which is consistent with Fitzgerald and Danielham (1987) who claimed that explicit instruction in the expectations of a genre can enhance children's writing. Williams and Casa (2015) asked children to talk about their thinking and then encouraged them to write down what they talked about, demonstrating a link between talking and writing about mathematical thinking. The importance of connecting oral discourse to written discourse became clear in this study when Daniel explained that he had solved the problem in his head before he got to his seat, but he was not sure how to write what he did. Sharing what he did through talk helped him begin to understand how to write down his thinking in both a representation and sentences. Interestingly, once the children began to understand the expectation for writing about their solution strategy, they started to write what they did before telling their peer as it appeared to solidify their thinking before trying to talk about it, perhaps demonstrating that writing about their strategy was increasing their metacognitive awareness (Pugalee, 2004).

Developing sociomathematical norms and discourse knowledge helped the children in this study more clearly communicate their thinking with their peers. Over the time period of the unit the children began providing added details in their accounts of their solution strategies and they began to learn from each other, over time producing more sophisticated solution strategies such as the use of invented algorithms.

As with Daniel, public conversations between the researcher and individual students also increased the teacher/researcher's awareness of a child's misunderstanding and/or his or her inability to merely communicate ideas. The insights gained by the teacher that are revealed in listening to oral discourse and reading written discourse are invaluable. In this study, oral and written explanations made public the conceptual understanding the students were developing in using base-ten to solve problems, providing valuable knowledge for planning future instruction. Although not documented in this study but noted informally, it appeared that adding written discourse in the two intervention classrooms also impacted not only clarity in communication, but development of conceptual

understanding as well, an area worthy of further study. If so, this would be consistent with the findings of Cohen et al. (2015), who found that having second-grade children respond to “deep thinking questions” in writing helped develop their conceptual understanding.

Attending to acceptable norms and mathematical language within the lessons gave the students an opportunity to focus their attention on translating their *thinking* into words (both orally and in writing) without undue concern about the correctness of the mathematics. Once discourse skills developed, the students were then able to attend to the mathematics and their conceptual understanding of adding and subtracting two-digit numbers improved. This is perhaps because students were acquiring the language they needed to share their thinking with a partner. They were then freed up to concentrate on the mathematics and on the ideas of their peers, allowing them to consider other ways to solve the problem.

The process of writing requires the writer to consolidate his or her thinking, helping to clarify knowledge (Neil, 1996). It is important to note then that only focusing on oral discourse and norms for sharing solution strategies did not appear to be enough to significantly improve the comparison groups oral responses. The addition of written explanations appears to have enhanced the intervention group’s ability to both talk and write about their solution strategies. In the current study, it appears that writing about how they solved the problem helped the children solidify their strategy for adding two-digit numbers, suggesting the value of the writing process itself.

As with all research, this study has several limitations. This study only looked at the change in student explanations from one school’s first-grade classrooms. Therefore, the sample size is small and not randomized. Further, results from different schools could vary based on the instructional practices of the teachers.

Interviews from the four teachers revealed that while they all use the same curriculum, their use of the curriculum varied, leaving the students with differing exposure to the first-grade standards. While every effort was made to teach the same lesson to each of the four classrooms, due to the nature of problem-based instruction, that was not entirely possible.

Also, it is difficult to elicit oral and written discourse without the use of problem-based mathematics instruction that encourages student participation. Future studies need to look at this pedagogical style within other mathematical strands and environments.

As the student, Sharon, in Levenson (2013) asked, “What does it mean to explain?” Many young children are unsure about what is expected when someone asks them to explain how they got their answer. It is important that teachers develop norms for what explaining entails, for sharing solution strategies within their classrooms, and for developing the language of mathematics. Through the use of cognitively demanding tasks which motivate a need to explain and explicit conversations about what it means to explain, the children in this study were more able to clearly share how they solved problems, a valuable first step in developing mathematical competency.

## REFERENCES

- Armstrong, R. A. (2014). When to use the Bonferroni correction. *The Journal of the College of Optometrists*, 34, 502-508. <https://doi.org/10.1111/opo.12131>
- Bicer, A., Capraro, R. M. and Capraro, M. M. (2013). Integrating writing into mathematics classroom to increase students’ problem solving skills. *International Online Journal of Educational Sciences*, 5(2), 361-369.
- Boaler, J. (2016). *Mathematical mindsets: Unleashing students’ potential through creative math, inspiring messages and innovative teaching*. San Francisco, CA: Jossey-Bass.
- Burns, M. (1995). *Writing in math class*. Sausalito, CA: Math Solutions Publications.
- Casa, T. M. (2015). The right time to start writing. *Teaching Children Mathematics*, 22(5), 269-271. <https://doi.org/10.5951/teachmath.22.5.0269>
- Casa, T. M., Firmender, J. M., Cahill, J., Cardetti, F., Choppin, J. M., Cohen, J., ... and Zawodniak, R. (2016). *Types of and purposes for elementary mathematical writing: Task force recommendations*. Available at: <http://mathwriting.education.uconn.edu>
- Cohen, J. (1988). *Statistical power analysis for the behavior sciences* (2nd ed.). Hillsdale, NJ: Erlbaum.
- Cohen, J. A., Casa, T. M., Miller, H. C. and Firmender, J. M. (2015). Characteristics of Second Graders’ Mathematical Writing. *School Science and Mathematics*, 115(7), 344-355. <https://doi.org/10.1111/ssm.12138>
- Department for Education. (2013). *The National Curriculum in England: Key Stages 1 and 2 framework document*. Available at: <https://www.gov.uk/government/publications/national-curriculum-in-england-primary-curriculum> (Accessed 14 June 2018).
- Faul, F., Erdfelder, E., Buchner, A. and Lang, A.-G. (2009). Statistical power analyses using G\*Power 3.1: Tests for correlation and regression analyses. *Behavior Research Methods*, 41, 1149-1160. <https://doi.org/10.3758/BRM.41.4.1149>
- Fitzgerald, J. and Danielham, L. (1987). Teaching children about revision in writing. *Cognition and Instruction*, 4, 3-24. [https://doi.org/10.1207/s1532690xci0401\\_1](https://doi.org/10.1207/s1532690xci0401_1)



- Fletcher, G. (2016). Pringle ringle. 3-Act Lessons. Available at: <https://gfletchy.com/the-pringle-ringle/>
- Gavin, M. K., Chapin, S. H., Daily, J. and Sheffield, L. J. (2006-2008). *Student Mathematician's Journal: Guides for Teaching and Assessing*. Project M3 series. Dubuque, IA: Kendall Hunt.
- Lee, C. (2006). *Language for Learning Mathematics: Assessment for Learning in Practice: Assessment for Learning in Practice*. McGraw-Hill Education (UK).
- Levenson, E. (2013). Exploring one student's explanations at different ages: The case of Sharon. *Educational Studies in Mathematics*, 83, 181-203. <https://doi.org/10.1007/s10649-012-9447-1>
- Levenson, E., Tirosh, D. and Tsamir, P. (2009). Students' perceived sociomathematical norms: The missing paradigm. *The Journal of Mathematical Behavior*, 28, 171-187. <https://doi.org/10.1016/j.jmathb.2009.09.001>
- Mannion, J. and Mercer, N. (2016). Learning to learn: Improving attainment, closing the gap at Key Stage 3. *The Curriculum Journal*, 27(2), 246-271. <https://doi.org/10.1080/09585176.2015.1137778>
- McClain, K. and Cobb, P. (2001). An analysis of development of sociomathematical norms in one first-grade classroom. *Journal for Research in Mathematics Education*, 236-266. <https://doi.org/10.2307/749827>
- Moyer, P. S. (2000). Communicating mathematically: Children's literature as a natural connection. *The Reading Teacher*, 54(3), 246-255.
- National Council of Teachers of Mathematics (NCTM). (2015). *Principles to action: Ensuring mathematical success for all*. Reston, VA: NCTM.
- National Council of Teachers of Mathematics (Ed.). (2000). *Principles and standards for school mathematics* (Vol. 1). Reston: VA, NCTM.
- National Governors Association Center for Best Practices, Council of Chief State School Officers (NGA Center and CCSSO) (CCSSM). (2010). *Common core state standards for mathematics*. Washington, D. C.: NGA Center and CCSSO.
- National Research Council (NRC). (2001). Adding it up: Helping children learn mathematics. J. Kilpatrick, J. Swafford and B. Findell (Eds.). *Mathematics Learning Study Committee, Center for Education, Division of Behavioral and Social Sciences and Education*. Washington, DC: National Academy Press.
- Olinghouse, N. G. and Graham, S. (2009). The relationship between the discourse knowledge and the writing performance of elementary-grade students. *Journal of Educational Psychology*, 101(1), 37-50. <https://doi.org/10.1037/a0013462>
- Partnership for Assessment of Readiness for College and Careers (PARCC). (2016). *PARCC high level blueprints-mathematics. Math Test Specification Documents*. Available at: <http://parconline.org/assessments/test-design/mathematics/math-test-specifications-documents>
- Pont, B. (2018). Curriculum reform: An education change perspective. Dublin, IR: *Policy Advice and Implementation Division Directorate for Education and Skills OECD*.
- Pugalee, D. K. (2004). A comparison of verbal and written descriptions of students' problem solving processes. *Educational Studies in Mathematics*, 55(1-3), 27-47. <https://doi.org/10.1023/B:EDUC.0000017666.11367.c7>
- Sfard, A. (2012). Introduction: Developing mathematical discourse-some insights from communicational research. *International Journal of Educational research*, 51, 1-9. <https://doi.org/10.1016/j.ijer.2011.12.013>
- Smith, M. S. and Stein, M. K. (2015). *Five practices for orchestrating productive mathematics discussions*. Reston, VA: NCTM.
- Stein, M. K., Engle, R. A., Smith, M. S. and Hughes, E. K. (2008). Orchestrating productive mathematical discussions: Five practices for helping teachers move beyond show and tell. *Mathematical Thinking and Learning*, 10(4), 313-340. <https://doi.org/10.1080/10986060802229675>
- Stigler, J. W. and Hiebert, J. (1999). *The teaching gap: Best ideas from the World's teachers for improving education in the classroom*. New York: The Free Press.
- Wright, D. B. (2003). Making friends with your data: Improving how statistics are conducted and reported. *British Journal of Educational Psychology*, 73, 123-136. <https://doi.org/10.1348/000709903762869950>
- Yackel, E. and Cobb, P. (1996). Sociomathematical norms, argumentation, and autonomy in mathematics. *Journal for Research in Mathematics Education*, 458-477. <https://doi.org/10.2307/749877>
- Yackel, E. (1995). Children's talk in inquiry mathematics class rooms. In: Cobb, P.; Bauersfeld, H. (Eds.): *The emergence of mathematical meaning: Interaction in classroom cultures*.

APPENDIX A

Rubric for Mathematical Explanations

Indicator	0	1	2	3
<b>Mathematical Concepts (Base-Ten)</b>	Student does not provide a written or oral explanation. Child did not have access to the problem.	Oral or written explanation demonstrates that the student has access to the problem, but has a lack of procedural and conceptual understanding of base-ten concepts. - does not refer to base-ten - counts all by ones - refers to tens and ones but does not elaborate	Oral or written explanation demonstrates partial or inconsistent understanding of base-ten addition and subtraction. - only refers to one quantity or the result in tens and ones - exhibits counting by tens error, e.g., 46, 56, 76 - adding digits	Oral or written explanation demonstrates a consistent conceptual understanding of base-ten concepts - Counts by tens - Decomposes numbers into tens and ones to solve the problem - Uses an invented algorithm
<b>Mathematical Communication</b>	Student does not provide an oral or written response or the response is unintelligible.	Oral or written explanation only states the tools used to find a solution, but does not refer to how the tools were used. - Refers to using tens and ones without telling how they were used - Does not indicate awareness of operation (added, put together etc.) - Refers to use of numbers, number sentences, pictures, circles without elaborating	Oral or written explanation states partially developed solutions, reasoning is incomplete. - Refers to the total quantity without explaining how it was obtained - Refers to the two quantities in the problem but does not tell how an answer was found. - Refers to one quantity and the solution - Refers to counting by tens strategy but does not elaborate	Oral or written explanation states adequately developed solution. The explanation clearly describes the steps taken to find the solution. - may not be mathematically accurate, but the explanation is clear, developed - explains how quantities were added (counted, added, put together, writes a number sentence)
<b>Mathematical Vocabulary</b>	Student does not use a mathematical vocabulary term.	Student uses one mathematical vocabulary term.	Student uses 2 mathematical vocabulary terms.	Student uses three or more mathematical vocabulary terms.
Terms: (in written, symbol, or numeral form) tens, ones, add, subtract, counted, equals, together, apart, take away, more, solved, number sentence, made				

Adapted from Gavin et al., 2006-2008, Rubric for Student Mathematicians Journal

## Social Amenities and Academic Performance in Primary Schools in Gichugu Constituency, Kenya

Priscah Wanjiku Githaka <sup>1</sup>, Michael W. Gachahi <sup>1\*</sup>, John Mwaruvie <sup>1</sup>

<sup>1</sup> School of Education and Social Sciences, Karatina University, KENYA

\*Corresponding Author: [mgachahi10@gmail.com](mailto:mgachahi10@gmail.com)

**Citation:** Githaka, P. W., Gachahi, M. W. and Mwaruvie, J. (2019). Social Amenities and Academic Performance in Primary Schools in Gichugu Constituency, Kenya. *European Journal of STEM Education*, 4(1), 04. <https://doi.org/10.20897/ejsteme/3948>

**Published:** April 29, 2019

### ABSTRACT

Social amenities in primary schools play an important role in the provision of quality education. Social amenities include play materials and sanitation facilities. This study aimed at examining the impact of social amenities on academic performance in primary schools in Gichugu Constituency, Kenya. The objectives of this study were to assess the status of social amenities, to establish how sanitation amenities influence pupils' performance and lastly, to evaluate challenges facing provision of social amenities in primary schools in Gichugu Constituency, Kenya. This study was guided by Social Constructionist Theory. The study adopted the descriptive survey research design. The target population consisted of 75 primary school head teachers. Kathuri and Pal's Table for Sample Size Determination was used to arrive at a sample size of 63 school head teachers who were randomly selected from the target population. A questionnaire and an observation guide were used to collect data from the respondents. Data was analyzed using descriptive statistics with the aid of Statistical Package for Social Sciences (SPSS Version 20). The study established that in majority of the primary schools, pupils had access to clean and safe drinking water though pupils in some schools used water from nearby rivers and stream. The study also found out that majority of the schools had adequate sanitation amenities. However, the study established that sanitation facilities did not cater for learners with physical disabilities. The study established that social amenities influenced learners' academic performance in primary schools. Further, the study established that financial challenges affected provision and maintenance of social amenities in primary schools in the study region. The study recommended that the Ministry of Education and other education stakeholders should facilitate the provision and maintenance of social amenities in primary schools in Kenya in order to improve pupils' academic performance.

**Keywords:** social amenities, sanitation, academic performance, play materials

### INTRODUCTION

One of the Millennium Development Goals calls on countries to reduce the proportion of people without access to basic sanitation by half (Guy and Haller, 2007). Williams et al. (2008) noted that eradication of open defecation, improved hand washing practices as well as ensuring that liquid and solid wastes are properly managed would not only help in ensuring proper sanitation practices but also save an estimated 1.9 billion school days that could be lost due to diarrhea illness and other water and sanitation-related diseases. It is important to note that schools are important and stimulating learning environments for children that have the potential to significantly alter the behaviour patterns of students leading to improved sanitation practices.

Social play amenities also include play materials which allow social development of children within the school and at home. Social play materials play an integral part in allowing children develop communication, persistence and other social skills necessary for development of language, motor skills as well as intellectual growth (Edwards, 2006). In a study conducted in American schools on the role of athletics and academic performance, Gorman (2010) studied how provision of play amenities influences growth and development of intellectual capacity of children. Gorman noted that there are children whose motivation in play influenced their intellectual development. Lack of these materials reduces their level of motivation and eventually results in poor intellectual development. This study disputed earlier findings of McMillen (1991) who had argued that athletics eligibility did not have any positive relationship with academic performance. The study also disputed Beem (2006) who noted that pressure to produce winning teams gave rise to lower academic performance among the top performers in schools. However, Gorman (2010) noted under school sponsorship programmes, the participants were more inclined to post positive academic achievements to be sustained in the schools. The current study excludes school sponsorships based on one's play prowess and therefore will be different from that of Gorman (2010). Gorman's study was based on senior school learners who were also highly involved in athletics and therefore the findings involved learners who were at advanced stages in their formative years unlike the current study that is exclusively on primary school children.

Owoeye and Yara (2011) conducted a study in Ekiti State, Nigeria to determine how social amenities in school contribute to academic performance of learners in schools. Using descriptive survey design of the ex-post factor type, the study determined that school social amenities whether health, sanitation, play amenities and academic oriented amenities all have an effect on academic performance. The study therefore argued that provision of academic and social amenities was paramount if the community were to have higher expectations in academics. The findings in this study corroborated the findings of Owoeye and Yara (2011) who argued that social amenities affected children's cognitive development and therefore directly influenced their academic performance. Nigeria is a relatively rich African country due to oil presence and therefore the status of the social amenities in these schools and the level of incomes of the parents among other factors could have influenced the results of the studies. Though Kenya is a developing country, the status of her primary schools may not match that of the Nigerian schools.

Gabbad and Elawad (2014) carried out a study covering around 500 primary schools in Sudan. This study found out that there was a significant relationship between access to potable water and intestinal parasite infection among primary school children. The study noted that the distribution of these infections was mainly associated with poor personal hygiene, environmental sanitation and limited access to clean water among pupils in primary schools in Elengaz region. In this study, Gabbad and Elawad concluded that the spread of intestinal parasitic infections in a population is generally associated with water supply and sanitation besides other factors. This study argued that diseases affected the grades that children achieved in their examinations and to a large extent affected their education progression.

Redhouse (2004) carried out a study in Tanzanian schools to determine the rate of access to safe drinking water. In this study, a sample of public schools was selected and was intended to determine how many school children had access to safe drinking water at a distance of 15 minutes away from the school. This study concluded that less than 12% of the public primary schools had access to safe drinking water. The study noted that lack of safe piped water contributed to prevalence of diseases associated with unsafe water such as typhoid and cholera. The study noted that such sicknesses contributed to lower academic achievement among children due to absenteeism and slow cognitive development due to illnesses. Kirinyaga is served by rivers emanating from Mt Kenya and thus the level of impurities and pollution in these rivers is low.

Milkie and Warner (2011) argued that schools should ensure that they have ample play amenities, access to play tools and teachers should be encouraged to participate in play activities together with learners. The authors argued that schools that lacked play amenities were unsuitable for learning particularly to early age learners. In order for learners to develop motor skills which are applied later in life, schools should provide a variety of amenities such as horizontal trunks, ropes and other play items that provide learners with a variety of play amenities which broaden their play scope. Lawrence (2011) argued that innovation in schools can increase involvement of learners during play. He found out that movement increases children's physical and cognitive abilities. It is through activities such as role play, seat changing, coordinated dances among others assist learners to get basic skills such as timing, coordination and concentration. These skills are very useful in the development of language and problem solving skills which can ultimately lead to improved academic performance.

In Kenya, Eshuchi (2013) carried out a survey of various campaigns in schools to improve the hygiene standards such as the *WASH Campaigns*. Eshuchi noted that the government and non-government stakeholders in Kenya have initiated hygiene promotion campaigns in public primary schools across the country. He noted that this includes curriculum developed by the Ministry of Public Health and Sanitation (MoPHS), the Ministry of Education (MoE), the Kenya Institute of Curriculum Development (KICD) together with other stakeholders

sensitizing the public on hygiene and sanitation. Dettol Hand Washing campaign is one of the strategies used to sensitize children on the need to wash hands. Mbula (2014) carried out a survey of sanitation amenities in schools in Machakos County, Kenya. Mbula noted that improved sanitation amenities are not limited to provision of latrines and water but also to the fact that these amenities should be well ventilated and should have slab floors. Mbula established a relationship between good social amenities and improvement in school attendance as well as overall performance of pupils in examinations.

## **STATEMENT OF THE PROBLEM**

Availability and maintenance of social amenities in learning institutions cannot be ignored. Public primary schools in Kenya face financial challenges which affect provision, maintenance and expansion of social amenities to cater for the increasing number of pupils occasioned by the introduction of free primary education in Kenya in 2003. It is therefore important that a study should be undertaken to assess the status of social amenities in primary schools in Kenya. Secondly, studies on the impact of social amenities on academic performance have not been exhaustive. Most of the studies in this area have been carried out in more developed countries whose conditions may not match the Kenyan context. The current study sought to establish the impact of social amenities on academic performance in primary schools in Gichugu Constituency, Kenya.

## **OBJECTIVES OF THE STUDY**

The following were the specific objectives of the study:

- i. To assess the status of social amenities in primary schools in Gichugu Constituency, Kenya.
- ii. To establish how sanitation amenities influence pupils' performance in primary schools in Gichugu Constituency, Kenya.
- iii. To evaluate challenges facing provision of social amenities in primary schools in Gichugu Constituency, Kenya.

## **THEORETICAL FRAMEWORK**

The study was guided by the Social Constructionist Theory as explained by Sahlin (2006). This theory posits that knowledge acquisition involves the following facets; language used, the surrounding community, social interaction and other cognitive functions which influence learners' intellectual development. This study is of the view that learners' knowledge acquisition is influenced by social engagements and that social amenities play a major role in the intellectual development of children. The provision of social amenities in schools assists learners in the development of social and intellectual skills which ultimately promote development of life skills which enable learners to cope with challenges in life. Social play materials provide learners with tools to exercise and develop their social skills. Social skills ensure learners are capable of interacting with other learners, the community and the society at large. Social processes therefore play a pivotal role in the development of intellectual thought and thus provision of social amenities could influence learners' academic performance.

## **RESEARCH DESIGN**

This study adopted the descriptive survey research design. According to Mugenda and Mugenda (2003), descriptive survey research design enables researchers to get information about a phenomenon under study from selected respondents. The target population was 75 primary school head teachers from Gichugu Constituency, Kenya. Kathuri and Pal's Table for Sample Size Determination was used to arrive at 63 head teachers who were randomly selected from the study region. The data collection instruments used in this study were questionnaires for headteachers and an observation guide. The headteachers' questionnaires contained open ended and closed ended questions which were directed towards collecting data on social amenities and academic performance in primary schools in Gichugu Constituency, Kenya.

## **FINDINGS**

The study sought to establish the status of social amenities in primary schools in Gichugu Constituency, Kenya. Information on status of social amenities in primary schools in this region was sought from the headteachers.

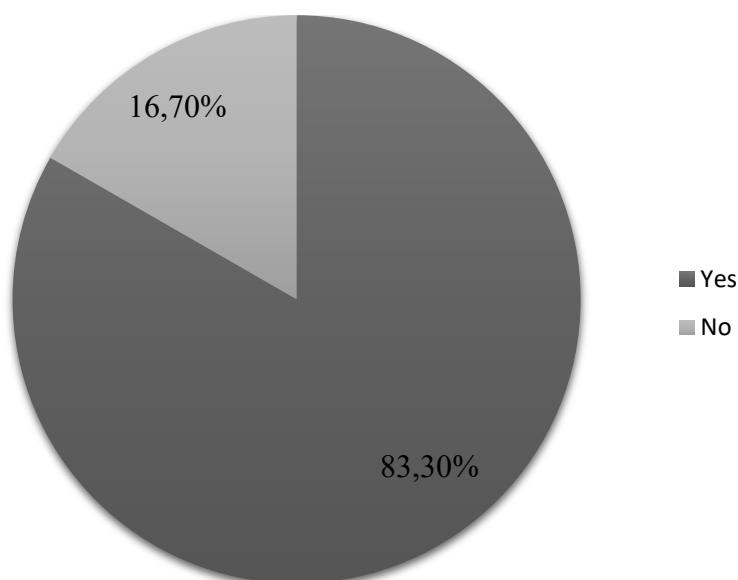

**Figure 1.** Status of Social Amenities in Primary Schools

**Table 1.** Adequacy of Sanitation Amenities

Average School Population	Ratio of Pupils to Toilets	Average Mean Grade (2014 KCPE)
200 – 250	1:25	240
	1:16	290
	1:13	327
300 – 500	1:50	180
	1:33	220
	1:25	250
500 – 800	1:14	325
	1:27	274
	1:20	315
	1:13	378

Headteachers were asked to indicate the status of various social amenities in their schools. **Figure 1** summarizes the status of social amenities in primary schools in the region with reference to water.

With reference to water, **Figure 1** shows that majority of the head teachers (83.3%) noted that their schools had access to clean safe drinking water. However, a considerable number of schools lacked safe clean drinking water (16.7%). It was observed that in the 16.7% schools without safe drinking water, learners depended on water from streams surrounding the school as shown in Appendix 1 which shows learners fetching water from a stream. The water from streams is not treated and may expose learners to health hazards such as disease causing pathogens. The findings of this study agree with the findings of Mbula (2014) who found out that majority of the primary schools in Kenya had access to safe and clean drinking water partly due to the efforts of Non-Governmental Organizations that had undertaken WASH campaigns in rural areas of the country. However, the findings of this study contradict Obure (2009) who noted that public school pupils in Bondo District did not have access to safe drinking water and depended on river and dam water which they fetched on their way to school.

The respondents were asked to indicate if their schools had adequate sanitation amenities for their learners. The results are as summarized in **Table 1**.

Data in **Table 1** show that majority of schools had inadequate sanitation amenities and this negatively affected their performance. There was evidence of an increased number of learner enrolment in schools with more sanitation facilities in the region due to better performance. However, the study observed that learners with physical disabilities shared the same sanitation facilities with others, thus learners with disabilities had difficulties using these facilities. The study also noted that in some schools, boys and girls shared the sanitation facilities. As shown in **Table 1** above, schools with a favourable student sanitation ratio posted better results. The study concluded that schools with more sanitation facilities had better results in the KCPE. The study agrees with Maphoso and Mahlo (2014) who established that learners in schools that had the best health, sanitation and other social amenities posted better results in the examinations compared to learners in schools that had poor, worn out or no social amenities. This could be explained by cases of learner absenteeism, poor health among other resultant features associated to poor social amenities.

**Table 2.** Social Amenities and Language, Motor and Intellectual Growth

Responses	Frequency	Percent
Strongly Agree	45	75.0%
Agree	15	25.0%
Do not Know	0	0.0%
Disagree	0	0.0%
Strongly Disagree	0	0.0%
<b>Total</b>	<b>60</b>	<b>100.0%</b>

**Table 3.** Diversity of Social Play Amenities and Children's Performance

Responses	Frequency	Percent
Strongly Agree	36	60.0%
Agree	24	40.0%
Do not know	0	0.0%
Disagree	0	0.0%
Strongly Disagree	0	0.0%
<b>Total</b>	<b>60</b>	<b>100.0%</b>

**Table 4.** Academic Performance in Sampled Schools

Year	2014	2013	2012
Average KCPE Marks Schools with piped water	Over 300	Over 280	302-315
Average KCPE Marks Schools without piped water	240-280	250-280	236-280

**Table 5.** Poor Sanitation Amenities and School Absenteeism

Responses	Frequency	Percent
Strongly Agree	32	53.3%
Agree	26	43.3%
Disagree	2	3.4%
Strongly Disagree	0	0.0%
<b>Total</b>	<b>60</b>	<b>100.0%</b>

## PLAY AMENITIES AND ACADEMIC PERFORMANCE

The study sought to find out the influence of play amenities on academic performance in the region. **Table 2** shows the results.

Data in **Table 2** above shows that majority (100%) of the school administrators agreed that play materials influenced learners' language development, psychomotor and intellectual growth. Play materials were observed to allow for development of persistence and other social skills necessary for the development of language, motor skills as well as intellectual growth. The researcher noted that swings, see-saws, football pitch and balls, merry-go-round, slides among others were common in most schools. The study established that all the social play materials play an integral part in allowing children to develop communication, persistence and other social skills.

The respondents were asked if provision of diverse social play amenities influenced the children's motivation and interaction and the responses are summarized in **Table 3**.

Data showed that all (100.0%) of the head teachers agreed that provision of diverse social play amenities influenced children's academic performance. The participants agreed that providing diverse social play materials motivates learners by providing a way for children to relax and indulge with others. The study noted that diversity of social play amenities influence children's academic performance.

The study sought to establish the relationship between sanitation amenities and academic performance of learners.

Data in **Table 4** above shows that the average performance of the schools with piped water in the area under study was over 300 marks compared to schools without piped water which had average marks of 240-280. The study therefore showed that schools with piped water had higher test scores compared to those without water. The findings corroborate Owoeye and Yara (2011) who noted that social amenities affected children's cognitive development and therefore directly influenced their academic performance. The respondents were asked if sanitation amenities affected enrollment and the responses are summarized in **Table 5**.

Data in **Table 5** showed that 96.6% of the head teachers agreed with the statement that poor sanitation amenities contributed to high incidences of absenteeism in schools. The data also showed that 3.4% of the head teachers disagreed with the statement. The study finds that poor sanitation amenities lead to an increase in the rate of absenteeism in schools. The findings concur with Gabbad and Elawad (2014) who noted that poor sanitation



**Table 6.** Financial Constraints in provision of Social Amenities

Responses	Frequency	Percent
Strongly Agree	47	78.3 %
Agree	13	21.7%
Do not know	0	
Disagree	0	0.0 %
Strongly Disagree	0	0.0%
<b>Total</b>	<b>60</b>	<b>100.0%</b>

in schools led to high cases of diseases among the learners resulting in higher rates of school absenteeism. This absenteeism led to low academic performance since learners miss valuable learning time.

## CHALLENGES FACED BY PRIMARY SCHOOLS IN PROVISION OF SOCIAL AMENITIES

The study sought to assess the challenges faced by primary schools in provision of social amenities to learners. The respondents were asked if financial constraints were a challenge in provision of social amenities in their schools and their responses are summarized in **Table 6**. The study showed that all (100.0%) of the head teachers agreed that financial constraints were a challenge in the provision of social amenities in public primary schools.

## CONCLUSIONS

The study concluded that social amenities play a pivotal role in development of communication, intellectual and physical growth among learners in primary schools. The study further noted that lack of essential social amenities such as access to clean, safe drinking water and lack of adequate sanitation led to increased incidences of absenteeism due to disease attacks. This high absenteeism led to low academic performance among learners. Schools with inadequate sanitation amenities also experienced lower enrollment rates compared to schools with adequate sanitation amenities.

## RECOMMENDATIONS

In line with the conclusions, the study made the following recommendations.

- i. The school administration should construct more sanitation amenities in their schools to correspond with the high population of children and also cater for learners with physical disabilities.
- ii. The Ministry of Education should develop a new construction requirement for early childhood learners' social amenities to ensure that the facilities are appropriate for children aged three to nine years in early childhood and lower primary schools.
- iii. Other social amenities such as electricity should be distributed to all buildings in primary schools to make them accessible to all learners.
- iv. The Ministry of Education and other education stakeholders should emphasize the role of social amenities in primary schools in order to improve the learners' motivation and overall academic performance.
- v. The school administration should ensure they provide diverse social amenities to cater for all learners and to encourage their cognitive and motor development. This could be achieved through maximum utilization of the school compound to cater for diverse disciplines and materials.

The Ministry of Education, Constituency Development Fund and the local community should ensure that all schools had access to piped water to reduce occurrence of diseases such as typhoid, cholera and other highly contagious diseases which affect learners' access to education through high absenteeism rates.

## REFERENCES

- Edwards, N. (2006). School Amenities and Student Achievement: Student Perspectives on the Connection between the Urban Learning Environment and Student Motivation and Performance. *Unpublished Masters Thesis. Ohio State University.*
- Eshuchi, R. (2013). Promoting Hand-washing with Soap Behaviour in Kenyan Schools: Learning from Puppetry Trials among Primary School Children in Kenya. *Unpublished Master's Thesis. Queensland University of Technology.*



- Gabbad, A. and Elawad, M. (2014). Environmental Sanitation Factors Associated with Intestinal Parasitic Infections in Primary School Children in Elengaz, Khartoum, Sudan. *Journal of Environmental Science*, 8(1), 119-121. <https://doi.org/10.9790/2402-0815119121>
- Gorman, D. A. (2010). The Effect of Athletic Participation on Academic Achievement for High School Seniors in Eastern Tennessee. *Unpublished Doctorate Thesis. Tennessee University.*
- Guy, H. and Haller, L. (2004). Evaluation of the costs and benefits of water and sanitation improvements of the global level. *WHO, Geneva.*
- Kathuri, J. N. and Pals, D. A. (1983). *Introduction to Educational Research*. Egerton University: Educational Media Center.
- Lawrence, B. M. (2011). Dramatic Play and Social/Emotional Development. *Unpublished Masters Thesis. Concordia University Portland.*
- Maphoso, L. and Mahlo, D. (2014). Basic Amenities and Academic Achievement: A Comparative Study between Boarding and Non-boarding Schools. *International Journal of Education and Science*, 6(2), 309-315. <https://doi.org/10.1080/09751122.2014.11890142>
- McMillen, T. (1991). Reversing the Imbalance of Athletics and Academics. *The Elementary School Journal*, 91(5), 489-90. <https://doi.org/10.1086/461671>
- Mbula, S., Mulwa, A. and Kyalo, D. (2014). Access to Improved Sanitation: Implication for Sustainable Implementation of Hygiene Practices Secondary Schools in Machakos County, Kenya. *European Scientific Journal*, 10(1), 151-168.
- Milkie, M. A. and Warner, C. H. (2011). Classroom Learning Environments and the Mental Health of First Grade Children. *Journal of Health and Social Behavior*, 52(1), 14-22. <https://doi.org/10.1177/0022146510394952>
- Mugenda, O. M. and Mugenda, A. O. (2003). *Research Methods: Qualitative and Quantitative Approaches*. Nairobi- Kenya: Africa Centre for Technology Studies (ACTS) Press.
- Obure, A. (2009). *Scaling School WASH in Rural Kenya: An Assessment of Kenya Education Sector Support Program*. Geneva.
- Owoeye, J. and Yara, P. (2011). School Amenities and Academic Achievement of Secondary School Agricultural Science in Ekiti State, Nigeria. *Asian Social Science*, 7(7), 64-66. <https://doi.org/10.5539/ass.v7n7p64>
- Redhouse, D. (2004). *Getting to boiling point: Turning up the heat on Water and Sanitation*. National Water Sector Assessments. Water Aid.

## APPENDIX I

School Children Fetching Water from a Nearby Stream





<http://www.lectitopublishing.nl>



<https://www.facebook.com/LectitoJournals/>



<https://twitter.com/lectito1>



<https://www.linkedin.com/in/lectito-journals-9a675010b/>

## Integrating Teachers to Teach an Interdisciplinary STEM-Focused Program about Sound, Waves and Communication Systems

Nayif Adil Awad <sup>1,2\*</sup>, Esmael Salman <sup>3</sup>, Moshe Barak <sup>1</sup>

<sup>1</sup> Ben Gurion University, ISRAEL

<sup>2</sup> Sakbnin Academic College, ISRAEL

<sup>3</sup> The Arab Academic College - Haifa, ISRAEL

\*Corresponding Author: [awad\\_nayif@yahoo.com](mailto:awad_nayif@yahoo.com)

**Citation:** Awad, N. A., Salman, E. and Barak, M. (2019). Integrating Teachers to Teach an Interdisciplinary STEM-Focused Program about Sound, Waves and Communication Systems. *European Journal of STEM Education*, 4(1), 05. <https://doi.org/10.20897/ejsteme/5756>

**Published:** April 29, 2019

### ABSTRACT

The insufficiency of teachers who teach integrative science, technology, engineering and mathematics (STEM) courses is a major challenge facing science education today. Many teachers lack adequate expertise to combine disciplines and choose effective instructional approaches. This study examines how and to what extent teachers might succeed in teaching an innovative STEM program about a sound, waves and communication systems course in an information and communication technology-based environment. This research adopted a qualitative method to understand better the experience of three teachers who taught the course for the first time. Data collection tools included documenting mentoring meetings, observing in the classrooms and interviewing the teachers. The data were transcribed and analyzed using the content analysis method. The findings show that the teachers had only partial knowledge and, initially, even misconceptions about sound. However, their technological pedagogic content knowledge improved significantly due to the researcher's gradual but continual guidance. Four major factors contributed to the teachers' professional development: (a) dealing with innovative contents, (b) using different (advanced) teaching methods, (c) pre-designing the instructional course materials and (d) offering the researcher-mentor's developmental supervision.

**Keywords:** STEM, sound wave, teachers' guidance

### INTRODUCTION

A recent challenge for educational systems worldwide relates to preparing teachers for science, technology, engineering and mathematics (STEM) education. Numerous studies have shown that many science teachers have limited STEM knowledge and do not eagerly embrace the idea of teaching STEM content (Kim et al., 2015; Nadelson et al., 2013; Skamp and Mueller, 2001; Yates and Chandler, 2001). In addition, it is well known from the educational literature that teachers are often inclined to teach what they had learned and in the way they had been taught (Deemer, 2004; Etkina et al., 2017; Llinares and Krainer, 2006). Consequently, fostering teachers' professional development has become an essential objective in preparing STEM teachers to increase student awareness and understanding about science and technology (Augustine, 2005; National Science Foundation, 2007; van Driel et al., 2012). However, the literature on training teachers – particularly prospective teachers – for STEM education is limited. Moreover, only a few studies (Shernoff et al., 2017) have examined teachers' mentoring processes and the way those processes affect teacher professional development. The present study addresses these

issues through the development, implementation and evaluation of a STEM-focused program about sound, waves and communication systems (SWCS) in a junior high school. It explores the effectiveness of training teachers to teach these innovative contents using the STEM approach and to examine the extent to which the guidance process may affect their professional development. We sought to identify factors that contribute to or hinder changes in teachers' knowledge, perceptions and practices.

The aim of this study was to examine and highlight the successes and problems novice teachers might encounter when teaching new STEM programs. Specifically, the study sought to answer the research questions:

1. What challenges do teachers face when teaching the SWCS program?
2. Which program factors affect teachers' professional development?

## LITERATURE REVIEW

### STEM Education

Education in STEM is widely recognized as national priority (Honey et al., 2014) and recent global challenges demand an interdisciplinary knowledge. Therefore, it has become imperative to combine these subjects, allowing students to connect contents and investigate issues deeply.

In K–12 settings, technology and engineering could serve a connector to engage students in integrative STEM with inquiry, problem solving and creativity. To affect such a change in schools, serious efforts are being made to transform from traditional learning approaches to STEM-focused strategies such as project-based learning. However, STEM implementation still faces several challenges, such as designing and investigating the effects of an explicit, integrated STEM program (Becker and Park, 2011) and providing teachers and educators with appropriate content knowledge in more than one (discrete) subject among the STEM subjects.

### Essential Knowledge to Teach Science

Teachers play a central role in the success or failure of introducing new curricula. A program's success depends largely on teachers' knowledge, skills and experiences. Shulman (1986, 1987) identified seven knowledge bases needed for effective teaching. In this section, we focus on the three most important knowledge types:

- *Content knowledge* (CK): knowledge about the subject matter to be learned or taught.
- *Pedagogical knowledge* (PK): knowledge of the processes and practices or methods of teaching, including about classroom management, assessment, lesson plan development and student learning.
- *Pedagogical content knowledge* (PCK): knowledge about pedagogy that applies to teaching specific content. Pedagogical content knowledge differs among various content areas because it blends both content and pedagogy with the goal of developing better teaching practices in the specific content areas.

This study aims to shed light on the development (or delay) processes related to these knowledge types.

### Technological Pedagogical Content Knowledge for STEM Education

In a world constantly evolving with an explosion of information and communication technologies (ICT), new technologies offer science education quick and flexible access to information, resources and experts (Williams et al., 2017). Mishra and Koehler (2006) suggested the term *technological pedagogical content knowledge* (TPCK) to describe knowledge essential to support intelligent uses of technology in teaching and learning, for example, to promote a student's ability to analyze and interpret data and acquire understanding of scientific concepts and spatial intelligence (Dani and Koenig, 2008; Koehler et al., 2007, 2013; Wu and Huang, 2007). However, many programs treat technology as an "add-on," isolated from the subject matter, without taking into account content–pedagogical considerations. Hence, they fail to yield a significant educational change (Angeli and Valanides, 2009).

A growing body of evidence suggests that supporting teachers with long-term professional development aimed at improving science instruction through technological support could create positive teacher and student outcomes (e.g., Bell et al., 2013). For example, Blanchard et al. (2016) reported encouraging effects of a 3-year, technology-enhanced professional development program on the beliefs and practices of 20 teachers. The teachers engaged in sustained inquiry-based experiences and used technology such as handheld probe-ware (e.g., pH, conductivity and heart rate), graphing calculators, interactive whiteboards and data analysis software in the context of the subject matter. Similarly, Longhurst et al. (2016) described a 2-year professional development program in which teachers learned four instructional modules focused on integrating inquiry-based science instruction using technologies such as Google Docs, photo- and video-editing, 3D virtual-simulation programs and educational gaming.

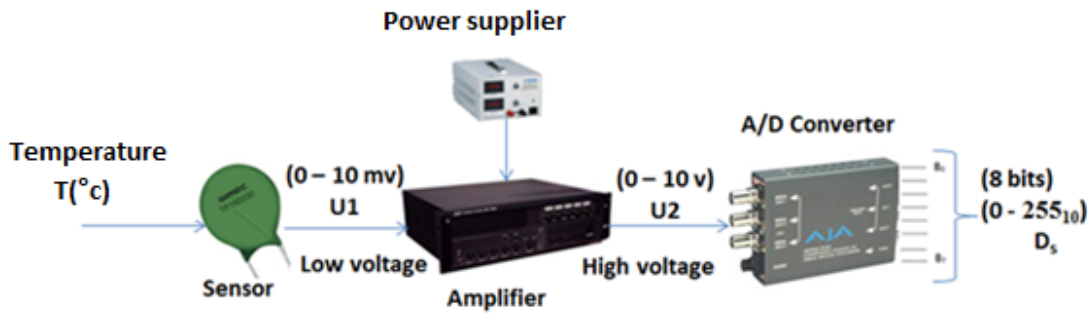

**Figure 1.** Sampling and analog-to-digital conversion process

### Essential Factors Affecting Professional Development

Many researchers (e.g., Desimone, 2009; Eylon and Bagno, 2006; Timperley et al., 2008; van Driel et al., 2012; Vescio et al., 2008) claimed that teacher professional development programs could assist in preparing qualified teachers when these programs are long-term, comprehensive and

- treat teachers as active learners who experience significant learning processes by themselves;
- focus on classroom practice and involve teachers in instructional processes directly related to students' learning about specific content; and
- engage teachers in collaborative learning (e.g., professional learning communities and collegial interactions) where they can conduct powerful conversation and reflective dialog about curriculum and instruction.

To bring about real change in teachers' perceptions and practices, teachers should receive continuous support and pursue ongoing, life-long professional learning (Kind, 2009).

It has been widely agreed that the mentoring approach should be adapted to the teacher's needs and professional development. Based on Glickman and Carranza's (1990) work on approaches to support professional development through personalized supervision, Barak et al. (1997) described developmental supervision as comprising three stages:

1. "Show me" (directive supervision) first,
2. "Let us think together" (collaborative supervision), and then
3. "Listen to me" (nondirective supervision)

Similarly, Yerushalmi and Eylon (2013) used the *customization workshop* as a professional development framework to bring curricular innovations into classrooms and foster expert pedagogical problem solving. The researchers referred to three mentoring approaches: minimal guidance, maximal guidance ("spoon-fed") and cognitive apprenticeship.

## SOUND, WAVES AND COMMUNICATION SYSTEMS COURSE

### Course Content

The SWCS course was designed to provide junior high school students with the scientific concepts of transverse wave, longitude wave, period, frequency, wavelength, amplitude, sound velocity and sound propagation on different materials or states of matter. The relevant technological concepts and ideas focused on sound systems, microphones, speakers, amplifiers, analog-to-digital conversion and digital sound. **Figure 1** describes the major phases of converting analog sound to digital sound. In addition, the students investigated advanced subjects related to sound waves through project-based learning about the Bluetooth protocol and the human ear and noise. Notably, the scientific and technological subjects were taught in an integrated fashion without formally distinguishing between science and technology.

### Instructional Methods

The course was run in two rounds over three successive years. In the pilot (first round) study, the instruction consisted mainly of the teacher's theoretical presentations (20–30 minutes) and students' self-learning with simulation (45–60 minutes). In the main (second round) study, we added significant changes to the instructional methods: Besides the use of simulation and ICT, sufficient time was allocated for class discussions, practical experiments (significantly expanded in scope and diversity) and project-based learning, which were re-organized,



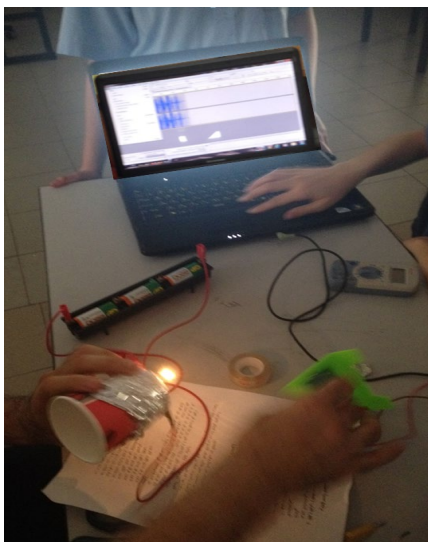

**Figure 2.** Recording and analyzing a sound wave by Audacity software

followed carefully by teachers and evaluated systematically. **Figure 2** depicts the students' work in constructing a light-based microphone. They recorded and analyzed a sound wave using Audacity® software.

### Teachers' Guidance Process

During the pilot study, the researcher met weekly with each of three teachers individually for about 1.5 hours (total of 20 hours). The most important functions of these meetings were providing the teachers with instructional materials and discussing scientific concepts such as wave, wavelength, frequency, current and voltage to ensure they comprehended the concepts well.

- During the main study, the researcher met with the same three teachers who had participated in the pilot study approximately once every 2 weeks (total of 10 hours). The meetings included:
- teacher's reflections on the last lesson, including the instruction strengths, weaknesses, difficulties and challenges;
- researcher-supported feedback according to the classroom observations;
- discussions about SWCS main concepts; and
- dialog about pedagogical matters, such as instructional methods and practices that the teachers should adopt.

## METHODOLOGY

### Participants

Three teachers, to whom we have given the pseudonyms Teacher 1, Teacher 2 and Teacher 3, participated in the current study. The teachers expressed high motivation to join the SWCS program and apply it in their schools, hoping such an experience will help them prepare for the coming reform in science education. The teachers met with the researcher regularly throughout the research, learned the course contents deeply and then taught it to middle (junior high) school students.

**Teacher 1** was 23 years old and had studied electronics in high school. After completing a Bachelor of Science (BSc) degree in the medical lab field, he worked as a laboratory assistant in a regional medical lab and as a part-time teacher in a regional out-of-school enrichment center. He started his teaching work before completing his teaching-certificate studies, which was acceptable according to the enrichment center requirements. Teacher 1 used to teach a course in biology. His participation in this research was the first time that he taught the SWCS course.

**Teacher 2** was 28 years old. He completed a Bachelor of Science (BSc) degree in physics and astronomy and taught physics for grades 7 through 10 at a comprehensive high school. Even though he lacked a teaching certificate, he had been recruited because of a lack in physics teachers in the region. Teacher 2 joined the SWCS course in his second year as a science teacher.

**Teacher 3** was 56 years old and had completed a Master (MA) degree in physics. He had more than 20 years' experience teaching high school physics. Having served as the physics teaching coordinator at school, he prepared students for the 5-study unit (the highest level) physics matriculation exam. In recent years, Teacher 3 became interested in teaching physics to younger ages and taught an elementary school course he prepared about "the

magic of gases.” Despite Teacher 3’s rich teaching experience, he has no prior knowledge in either teaching integrative STEM or applying modern pedagogical strategies.

The researcher served as mentor for the three teachers alongside to his main responsibility of conducting the research. In addition, the researcher supported the teacher’s instruction in the class when needed.

### Data Collection and Analysis

Data about the teachers’ integration in teaching the new SWCS course were collected in both the pilot and main studies. Data collection methods consisted of

- documenting mentor meetings with each teacher and taking notes about special events, behaviors or statements that emerged;
- observing the teachers’ instruction in the school and writing notes about their class work, including the extent to which they had mastered the content knowledge and used the instructional methods. Such observations were especially important to note whether the students only partially understood the contents under discussion or developed alternative ideas. The mentor attended more than 85% of the course sessions in the pilot phase and nearly half of the sessions in the main study; and
- interviewing the teachers at the end of the course. A final interview of 30–40 minutes was conducted with each teacher.

Qualitative data analysis was performed using the content analysis method, which can be conducted either inductively or deductively (Elo et al., 2014). These two content analysis processes involve three main stages: preparation, organization and reporting results. The preparation stage consists of collecting suitable data for analyzing content, finding meanings in the data and selecting the analysis units. In inductive content analysis, the organization stage includes open coding, category creation, and abstraction (Creswell and Plano, 2007; Elo and Kyngäs, 2008). In deductive content analysis, the organization stage involves developing a category matrix and examining or encoding all the data for correspondence with or demonstration of the identified categories (Polit and Beck, 2012).

In the current study, the qualitative findings, which were collected through class observations, mentor’s documentations and interviews, were all analyzed using inductive content analysis that included preparation of data, recording and transcription of the interviews; re-reading the data; finding meaning in the data; and selecting meaningful content units. The data organization included open coding, creating main categories and subcategories, and reporting the results. Four main categories emerged as prominent in the data analysis: (a) course content, (b) pedagogical strategies, (c) technology and ICT use and (d) apprenticeship and mentoring. We then further divided each category into three or four subcategories.

## FINDINGS

### Challenges Teachers Faced when Teaching the SWCS Program

#### *Initial difficulty with subject matter*

During classroom observations in the pilot study, the researcher noticed that Teacher 1 and Teacher 2 (the two novice teachers) presented only partial explanations for, or inaccurate analogies to, the SWCS concepts. For example, Teacher 1 used analogies of tides and heartbeats to explain compression and rarefaction processes that occur when a wave propagates. Teacher 2 explained a particle’s vibration in a sound wave as analogous to vibration in a swing spring or pendulum. These sorts of incorrect explanations or analogies may have led to student misconceptions. Moreover, in the middle of the course, both teachers provided incomplete answers when students asked complex questions, such as how sound travels through a telephone or mobile phone. Even Teacher 3, the experienced teacher, encountered difficulty providing simple explanations about concepts such as voltage, electrical current and energy. All three teachers had limited knowledge about technological electronic components such as resistors, diodes, transistors and their functions in an electric circuit – subjects that are usually little addressed in physics classes.

In the guidance meetings, the mentor provided the teachers with the missing knowledge and discussed with them how to explain complex concepts. Nevertheless, when in the final (pilot study) interviews the teachers were asked about difficulties they encountered in teaching the course, all three described difficulty learning new contents and imparting “unripe” knowledge to students in a short time. Teacher 3 explained:

The moment you acquire new content; you need sufficient time before you can be ready to convey it to your students.



### ***Difficulty adopting a new pedagogical approach***

- Neither Teacher 1 nor Teacher 2 had teaching certificates, and both had limited knowledge about teaching strategies. Their lessons focused mainly on providing theoretical explanations. Teacher 3 also tended to teach in a traditional way. Although theoretical instruction was dominant in all cases, the teachers' motives seemed to vary. For example, whereas their lack of pedagogical knowledge might have played a role in the cases of Teacher 1 and Teacher 2, the regular instruction habit, and lack of motivation to change might have influenced Teacher 3's difficulty adopting a new approach.
- In the pilot study, the researcher guided the teachers to integrate class presentations with students' use of technological tools, such as simulations and instructional websites. In practice, Teacher 3 spent most of the class lesson time on theoretical presentations, and Teacher 1 and Teacher 2 devoted most of the time to students' work with computers. To summarize, we can say that despite the difference between Teacher 3 and the other teachers (Teachers 1 and Teacher 2) regarding the extent they emphasized theory and ICT components, all of them applied the lesson plans exactly as prepared by the researchers without initiating substantial changes.
- In the main study, the researcher together with the teachers designed the instructional method. They thought together about the lesson plans, paying more attention to include four elements:
  - A short (15-minute) teacher presentation
  - Class discussions
  - Use of ICT tools
  - Laboratory experiments

In addition, they designed the instruction to gradually integrate project-based learning into the course. Although the teachers still encountered several difficulties (e.g., in explaining scientific concepts regarding a physical phenomenon, choosing suitable software or carrying out lab demonstrations), their teaching and their students' learning in the class improved significantly in comparison with the pilot study, as expressed in the middle exam results in each round. In this phase, Teacher 3 managed to develop as an independent teacher showing an extent of creative initiative. On the other hand, only Teacher 2 developed as an independent teacher, whereas Teacher 1 did not show serious development. More details are described later.

### **Program Factors that Affect Teacher Professional Development**

All three teachers expressed initial interest in joining the SWCS course as a stage in their professional development. For example, when asked at the initial meeting why he was interested in teaching the SWCS course, Teacher 1 commented:

I think it is an opportunity to learn from a veteran professional teacher [points to the researcher]... My feeling is that this course brings different methods of work and that teachers who join it will receive support and encouragement.

In the first interview, Teacher 2 explained:

It was my first year teaching physics. ... I believe that taking the SWCS course will help me learn more about teaching physics in school.

Teacher 3 discussed his desire to participate in teaching the SWCS course to focus on introducing changes in physics teaching to spark student curiosity about physics and encourage them to choose physics in high school:

I want to know more about new ways and approaches for teaching physics. ... This could help me convince good students to major in physics in high school. ... The fact that the course is offered under the supervision of a research university encouraged me a great deal.

### ***Acquiring pedagogical content knowledge***

Findings from classroom observations and teacher interviews showed that the teachers in this study acquired PCK by iterative processes of using pre-instructional materials, attending guidance meetings and teaching the course in the classroom. In the following section, we describe how the mentor's developmental supervision improved the teachers' knowledge and practices.

**Mentor explanations and demonstrations: The "show me" phase.** In the pilot study, the mentor devoted a significant part of the guidance meetings to teaching the teachers about the SWCS subjects. He adapted his instruction to each teacher's knowledge level and needs. For example, the teachers' knowledge about analog waves varied. Teacher 1 was familiar with physics concepts only technically: He pointed out the wavelength and period

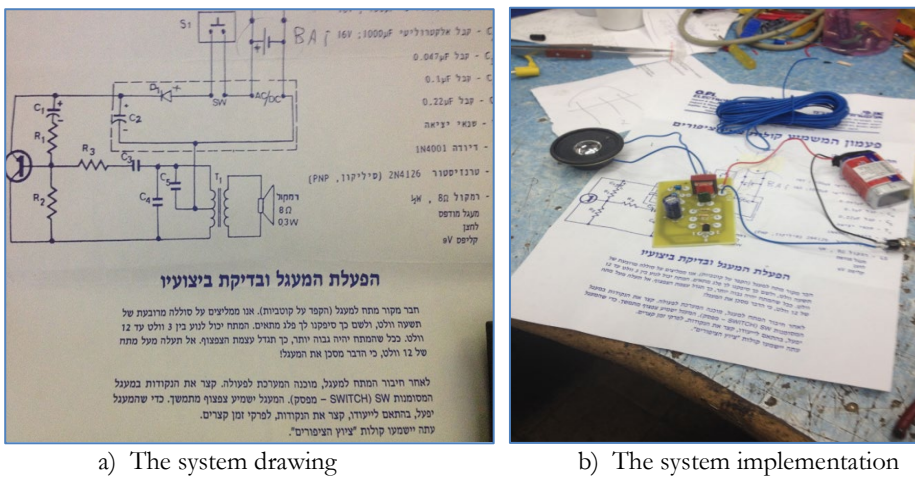

a) The system drawing

b) The system implementation

Figure 3. The electronic tweet bell

time on a graph but did not fully comprehend their meanings. The mentor used the pre-instructional materials to explain the concepts in detail. Teacher 2, who had taught tenth grade students about waves for 1 year, had partial knowledge about differences between sound and light waves or, more generally, between mechanical and electromagnetic waves. The mentor discussed with Teacher 2 how he should treat these subjects in school. Teacher 2 also had difficulty finding appropriate experiments and demonstrations and doubted his self-efficacy to carry out experiments in class. Over the course of the guidance meetings, the mentor showed him some simple experiments and explained them gradually. For example, the mentor presented the differences in covering an alarm clock and mobile phone with foil – although the alarm clock still produced a sound (at lower volume), the mobile phone showed no connection. Conversely, Teacher 3 was very familiar with the instructional materials about analog waves and was more interested in listening to the mentor's explanations. Teacher 3 commented about his satisfaction with the mentor's emphasis on promoting an “understanding” approach to teaching physics to younger children.

All three teachers asked the mentor for detailed explanations about technological subjects, such as sound amplification system, sampling, analog-to-digital conversion and digital sound. The mentor explained these subjects several times, gave examples and guided the teachers to combine their theoretical explanations with their students' use of the simulation. In addition, the mentor worked with the teachers to build an electronic tweet bell while explaining to them about the electronic circuit and the components that comprised it (Figure 3).

The classroom observations revealed that all three teachers relied on the pre-instructional materials (i.e., teacher presentations and student class activities) during their class teaching. Furthermore, in trying to imitate the mentor's explanations accurately, especially Teacher 1 and Teacher 2 (novice teachers) paid little attention to the students' understanding. However, at the end of the pilot study, the teachers expressed their satisfaction with the pre-instructional materials:

It was a good idea to prepare these presentations and activities for us; without them, I might have been lost. ... In this way, I at least have a clear direction or framework. (Teacher 1)

Having the course materials ready gave me a lot of confidence. ... It is much easier than constructing everything by yourself. (Teacher 2)

The prepared contents were very important...I used them although I have the knowledge. ... I cannot imagine how you can carry out research without determining the contents in advance; otherwise, every teacher would focus on different aspects. (Teacher 3)

To summarize, in the pilot study the mentor adopted the ‘direct or “show me”’ approach to guiding the teachers in order to bridge gaps in the teachers' subject matter knowledge.

**Mentor and teacher discussions: The “let us think together” phase.** At the beginning of the main study, the mentor considered the teachers as partners or colleagues and helped them develop gradually. In the guidance meetings, they dealt with the SWCS contents and placed special emphasis on promoting teaching strategies, especially hands-on experiments and use of ICT tools. The teachers proposed new ideas for experiments and activities and discussed them with the mentor. In addition, the mentor engaged the teachers in assessing students' understanding and examining their work. He encouraged the teachers to discuss their students' difficulties and together they thought about ways to overcome them. For example,

- Many of Teacher 1's students were not familiar with how wire parameters, such as tension, type and thickness, affect wave progress. The mentor and Teacher 1 sought a suitable simulation, and the teacher presented it to the students.
- Many of Teacher 2's students were unable to sort out sound velocity in air, helium and nitrogen. The mentor and Teacher 2 performed an experiment in the classroom and measured sound velocity in the different gases.

In coordination with the mentor, all three teachers tried to implement the instructional model (described earlier) in their classes. Teacher 1 and Teacher 2 even used a timer to ensure that they did not exceed each activity's time limit. They adjusted their lesson plans according to insights derived from the model's implementation and shared their impressions with the mentor.

Findings from the classroom observations indicated that Teacher 1 and Teacher 2 started to move freely among the students in the class, helping them and asking questions to examine their understanding. They also became more confident to carry out real laboratory experiments on their own, conduct class discussions and insist on clear and accurate scientific explanations from their students.

In the interviews, the mentor asked the teachers whether they perceived any change in the level or manner of guidance from the pilot to the main study. All three teachers mentioned a significant change:

In the pilot study, I felt like a student who is learning new content, while now in the main study, I am learning more about the dynamic work in the class. ... We managed to make a better connection between the guidance meetings and teaching in the class. I think that the mentor's attendance in the class contributed to this. (Teacher 1)

I felt freer and more confident in this phase...After my exposure to the course contents in the pilot study, I was ready to improve myself and improve my instruction. ... I contributed more to the discussions in the guidance meetings and worked in collaboration with the mentor. (Teacher 2)

**Teachers as independent instructors: The "listen to me" phase.** In the middle of the main study, the mentor began to encourage the teachers to engage in more self-work and take responsibility for teaching in the class. Two of the three teachers developed new content, suggested creative experiments not included in the original course and tried them out with their students. For example, Teacher 2 prepared a detailed presentation rich with ICT tools about electronics components that students used to construct the tweet bell. He also proposed a new experiment for sampling room temperature using the MultiLab program to demonstrate the essence of the sampling operation to the students. Teacher 3 suggested constructing a light-based microphone (in which sound causes changes in light received by a solar cell) alongside the carbon and magnetic microphones and used the Audacity® program to show the electric signals. The teachers commented on their motivations behind their actions:

It was very important to me that students not only construct the tweet bell, but also understand how the electric circuit works, as well as the contribution of each component. (Teacher 2)

We always think about carbon and magnetic microphone. I thought it would be interesting to try out an innovative idea – the light-based microphone.... I feel confident enough to take this risk with my students. I was not afraid to face failure. (Teacher 3)

After approximately 9 weeks, Teacher 2 and Teacher 3 showed a high level of confidence to change lessons plans and adapt them to the students' needs. For example, when Teacher 2 discovered that some students were still unable to distinguish between concepts such as pressure and intensity or mass and weight, he immediately presented simple demonstrations to clarify the concepts. Teacher 2 and Teacher 3 also provided simplified but accurate explanations to unexpected questions the students raised regarding complex concepts such as electrical fields, magnetic fields, AC and DC currents and sampling resolution. Nevertheless, Teacher 1 still relied heavily on the basic materials the mentor had prepared, investing little effort to develop the course. Researcher-mentor discussions did not help because Teacher 1 was more committed to his work in the medical lab than to teaching.

Towards the end of the course, the mentor discussed with the teachers the factors that contributed or hindered their professional development. All three mentioned that the atmosphere of safety and support and the personal relationship with the mentor based on mutual respect contributed to the tutoring process success. Teacher 1 recommended devoting more hours to this curriculum in the future and rewarding teachers financially for participating in the program.

### *Attaining technological pedagogical content knowledge*

At the beginning of the current study, novice Teachers 1 and 2 thought the use of ICT tools meant merely entering an Internet website or viewing a YouTube video. The veteran teacher, Teacher 3, expressed reservations about the use of ICT tools and exhibited a somewhat negative attitude. However, the SWCS course included the use of simulations and animations to explain complicated concepts such as wave, sampling and resolution. In addition, the Audacity® software was used to manipulate sound, including recording, editing and analysis; the MultiLab data analysis program used to collect, investigate and present data in tables and graphs (e.g., it was used in the experiment presented in [Figure 2](#)); Google Sites for building new websites (e.g., to present the final project); and discussions forums to argue the course subjects after class.

The mentor guided the teacher on how to use the tools technically and use their potential to make learning about sound and waves meaningful. In addition, the mentor guided the teachers individually according to their needs and questions. For example, Teacher 2 expressed interest in using videos, and the mentor showed him how to convert static videos to dynamic, interactive videos using the Edu-Tube and Zaption websites. Teacher 3 was interested in summarizing his lessons by engaging the students in learning games, and the mentor guided him in building one in the form of “The Race to the Million.”

To conclude, the mentor’s contribution was crucial for integrating the use of ICT tools into the SWCS course. Without the mentor’s help, the teachers might have continued their traditional teaching without integrating ICT tools. Instead, given the examples the mentor prepared and the talks he held with the teachers, they recognized the potential of educational technology and began using it.

## DISCUSSION AND CONCLUSION

In this paper, we examined the guidance provided to help teachers teach a new STEM curriculum about sound waves and communication systems, and explored factors that might stimulate or hinder the process. The participants comprised three teachers, two of whom were novice teachers and one a veteran teacher with more than 20 years’ experience in teaching physics. None had taught the SWCS course before the study.

In the literature review, we focused on two central aspects relevant to the current study. The first was teachers’ knowledge about subject matter and their mastery in instructional strategies, based on the concepts Shulman (1987) coined as PCK –pedagogical content knowledge. Recently, the term PCK was extended to TPCK to reflect technological pedagogical content knowledge (Kohen and Kramarski, 2012). The second referred to the literature about mentoring teachers (Borko et al., 2010; Pegg et al., 2010; van Driel et al., 2012; Yerushalmi and Eylon, 2013), focusing on the notion of *developmental supervision*. This term expresses the idea of customizing the guidance approach to teachers’ needs and professional development (Barak et al., 1997; Glickman and Carranza, 1990; Greene, 1992; Yerushalmi and Eylon, 2013).

Regarding the teachers’ content knowledge at the outset of the study, the findings show that although the more experienced teacher was familiar with the subject of waves and sound, such as analog waves and amplification, he tended not to provide detailed explanations of scientific concepts such as wavelength and resonance or characterization of amplification. The two novice teachers had only partial knowledge and even a few misconceptions about sound phenomena. Moreover, all three teachers lacked knowledge about technological subjects, such as sampling, analog-to-digital conversion and digital sound.

Further, from the pedagogical aspect, all three teachers mainly used traditional teaching methods and lacked adequate practical pedagogical knowledge on how to teach using a combination of theory, lab experiments, ICT tools and project-based learning in a STEM-focused program such the SWCS course. Four factors affected the teachers’ professional development in these aspects throughout the course:

- Innovative content. The SWCS course dealt with imparting new authentic topics related to sound and waves – a well-known subject from the physics field – in a new approach that combines the STEM subjects.
- Advanced instructional methods. The SWCS course imparted to teachers rich methods for science instruction that constitute state-of-the-art approaches in teaching and learning, for example, integrating theoretical teaching, lab experiments, use of ICT tools, simulation and project-based learning.
- Instruction design. The mentor prepared the initial instructional materials (e.g., theoretical presentations, lab experiments and class activities) for both the teachers and the students. These teaching and learning resources contributed to effective guidance and facilitated teaching the course in the classroom. Towards the end of the course, two teachers developed professionally and prepared new learning materials independently.
- Intensive guidance. The mentor supported the teachers throughout the course in guidance meetings and by attending the course sessions in the class. The mentor customized this guidance according to the teachers’ development level and needs. He moved smoothly through a developmental supervision between the “show me,”

“let us think together,” and “listen to me” approaches. Thus, the mentor observed the lessons, discussed each teacher’s practices with them, listened to their reflections and provided constructive feedback.

Notably, all four components were essential to encourage teachers to initially teach and then continue the SWCS course. If any one component were missing, presumably the teachers would not have been ready to teach the course and would have spent considerable time preparing the course and getting the mentor’s guidance.

Developing teachers’ TPCK was critical for the program’s successful implementation in the field. Nevertheless, it is worth noting that the mentor’s personal guidance constituted only a partial answer to dealing with the issue of preparing STEM teachers. There remains a serious need to integrate science teachers into long-term programs that support them as they collaboratively develop their professional knowledge in groups (Borko et al., 2010). Levy (2017) suggested an example of how to address physics teaching challenges within the framework of professional learning communities. Deep discussion and exposure to the SWCS program in regional professional communities – based on the active experiences of teachers who act as learners, classroom teachers and leaders of physics teachers – could contribute meaningfully to endeavors that promote integrating teachers to teach STEM-focused programs. Therefore, to promote interdisciplinary instruction among teachers, we propose organizing professional training with specific STEM-oriented programs that emphasize aspects of contents, pedagogies and technology together, and simultaneously enable teachers to implement the principles taught with pupils in schools. In addition, we recommended establishing professional communities that combine both novice and veteran teachers in each area.

## LIMITATIONS AND RECOMMENDATIONS

Three teachers participated in this study, of whom only one was qualified and experienced. The other two had a weaker background in teaching physics. The findings indicated common and different needs they had during training. However, meaningful training has the potential of contributing significantly to both. In light of the large shortage of teachers for STEM teaching, which is considered a relatively new approach, it is reasonable to assume that educational systems in different countries will invest resources to train STEM teachers of both types. This study should be extended to a larger population in order to examine the integration processes of teachers of both types. We recommend conducting future research with a larger sample of participants from more diverse populations (e.g., including both male and female teachers from different countries and cultures).

## REFERENCES

- Angeli, C. and Valanides, N. (2009). Epistemological and methodological issues for the conceptualization, development, and assessment of ICT-TPCK: Advances in technological pedagogical content knowledge (TPCK). *Computers and Education*, 52(1), 154–168. <https://doi.org/10.1016/j.compedu.2008.07.006>
- Augustine, N. R. (2005). *Rising Above the Gathering Storm: Energizing and Employing America for a Brighter Economic Future*. Washington, DC: National Academy Press.
- Barak, M., Pearlman-Avni, S. and Glanz, J. (1997). Using developmental supervision to improve science and technology instruction in Israel. *Journal of Curriculum and Supervision*, 12(4), 367–382.
- Becker, K. H. and Park, K. (2011). Integrative approaches among science, technology, engineering and mathematics (STEM) subjects on students’ learning: A meta-analysis. *Journal of STEM Education: Innovations and Research*, 12(5/6), 23–37.
- Bell, R. L., Maeng, J. L. and Binns, I. C. (2013). Learning in context: Technology integration in a teacher preparation program informed by situated learning theory. *Journal of Research in Science Teaching*, 50(3), 348–379. <https://doi.org/10.1002/tea.21075>
- Blanchard, M. R., LePrevost, C. E., Tolin, A. D. and Gutierrez, K. S. (2016). Investigating technology-enhanced teacher professional development in rural, high poverty middle schools. *Educational Researcher*, 45(3), 207–220. <https://doi.org/10.3102%2F0013189X16644602>
- Borko, H., Jacobs, J. and Koellner, K. (2010). Contemporary approaches to teacher professional development, in E. Baker, B. McGaw and P. Peterson (eds), *International Encyclopedia of Education* (pp. 548–555). Oxford: Elsevier.
- Creswell, J. W. and Plano, C. V. L. (2007). *Designing and Conducting Mixed Methods Research*. Thousand Oaks, CA: SAGE.
- Dani, D. and Koenig, K. M. (2008). Technology and reform-based science education. *Theory into Practice*, 4(3), 204–211. <https://doi.org/10.1080/00405840802153825>
- Deemer, S. (2004). Classroom goal orientation in high school classrooms: Revealing links between teacher beliefs and classroom environments. *Educational Researcher*, 46(1), 73–90. <https://doi.org/10.1080/0013188042000178836>



- Desimone, L. M. (2009). Improving impact studies of teachers' professional development: toward better conceptualizations and measures. *Educational Researcher*, 38(3), 181–199. <https://doi.org/10.3102%2F0013189X08331140>
- Elo, S., Kääriäinen, M., Kanste, O., Pölkki, T., Utriainen, K. and Kyngäs, H. (2014). Qualitative content analysis: A focus on trustworthiness. *SAGE Open*, 4, 1–10. <https://doi.org/10.1177/2158244014522633>
- Elo, S. and Kyngäs, H. (2008). The qualitative content analysis process. *Journal of Advanced Nursing*, 62, 107–115. <https://doi.org/10.1111/j.1365-2648.2007.04569.x>
- Etkina, E., Gregorcic, B. and Vokos, S. (2017). Organizing physics teacher professional education around productive habit development: A way to meet reform challenges. *Physical Review Physics Education Research*, 13(1), 010107. <https://doi.org/10.1103/PhysRevPhysEducRes.13.010107>
- Eylon, B. S. and Bagno, E. (2006). Research-design model for professional development of teachers: Designing lessons with physics education research. *Physical Review Special Topics-Physics Education Research*, 2(2), 020106. <https://doi.org/10.1103/PhysRevSTPER.2.020106>
- Glickman, I. and Carranza, F. A. (1990). *Glickman's Clinical Periodontology*. Philadelphia: Saunders.
- Greene, M. L. (1992). Teacher supervision as professional development: Does it work? *Journal of Curriculum and Supervision*, 7(2), 131–148.
- Honey, M., Pearson, G. and Schweingruber, A. (2014). *STEM Integration in K-12 Education: Status, Prospects, and an Agenda for Research*. Washington: National Academies Press.
- Kim, C., Kim, D., Yuan, J., Hill, R. B., Doshi, P. and Thai, C. N. (2015). Robotics to promote elementary education pre-service teachers' STEM engagement, learning, and teaching. *Computers & Education*, 91, 14–31. <https://doi.org/10.1016/j.compedu.2015.08.005>
- Kind, V. (2009). Pedagogical content knowledge in science education: Perspectives and potential for progress. *Studies in Science Education*, 45(2), 169–204. <https://doi.org/10.1080/03057260903142285>
- Koehler, M. J., Mishra, P. and Cain, W. (2013). What is technological pedagogical content knowledge (TPACK)? *Journal of Education*, 193(3), 13–19. <https://doi.org/1177%2F002205741319300303>
- Koehler, M. J., Mishra, P. and Yahya, K. (2007). Tracing the development of teacher knowledge in a design seminar: Integrating content, pedagogy, and technology. *Computers & Education*, 49(3), 740–762. <https://doi.org/10.1016/j.compedu.2005.11.012>
- Kohen, Z. and Kramarski, B. (2012). Developing a TPACK-SRL assessment scheme for conceptually advancing technology in education. *Studies in Educational Evaluation*, 38(1), 1–8. <https://doi.org/10.1016/j.stueduc.2012.03.001>
- Levy, S. (2017). *Professional Development of Leading Physics Teachers in Professional Learning Community* (Doctoral dissertation). Weizmann Institute of Science, Israel.
- Llinares, S. and Krainer, K. (2006). Mathematics (student) teachers and teacher educators as learners, in A. Gutierrez and P. Boero (eds), *Handbook of Research on the Psychology of Mathematics Education (pp. 1-18)*, Rotterdam: Sense.
- Longhurst, M. L., Coster, D. C., Wolf, P. G., Duffy, A. M., Lee, H. and Campbell, T. (2016). Multi-year professional development grounded in educative curriculum focused on integrating technology with reformed science teaching principles. *School Science and Mathematics*, 116(8), 430–441. <https://doi.org/10.1111/ssm.12197>
- Mishra, P. and Koehler, M. J. (2006). Technological pedagogical content knowledge: A new framework for teacher knowledge. *Teachers College Record*, 108, 1017–1054. <https://doi.org/10.1111/j.1467-9620.2006.00684.x>
- Nadelson, L., Callahan, J., Pyke, P., Hay, A., Dance, M. and Pfiester, J. (2013). Teacher STEM perception and preparation: Inquiry-based STEM professional development for elementary teachers. *Journal of Educational Research*, 106, 157–168. <https://doi.org/10.1080/00220671.2012.667014>
- National Science Foundation. (2007). *A National Action Plan for Addressing the Critical Needs of the U.S. Science, Technology, Engineering, and Mathematics Education System*. Available at: [http://www.nsf.gov/nsb/edu\\_com/draft\\_stem\\_report.pdf](http://www.nsf.gov/nsb/edu_com/draft_stem_report.pdf). (Accessed 20 November 2017).
- Pegg, J. M., Schmoock, H. I. and Gummer, E. S. (2010). Scientists and science educators mentoring secondary science teachers. *School Science and Mathematics*, 10(2), 98–109. <https://doi.org/10.1111/j.1949-8594.2009.00013.x>
- Polit D. F. and Beck C. T. (2012). *Nursing Research: Principles and Methods*. Philadelphia, PA: Lippincott Williams and Wilkins.
- Shernoff, D., Sinha, S., Bressler, D. and Ginsburg, L. (2017). Assessing teacher education and professional development needs for the implementation of integrated approaches to STEM education. *International Journal of STEM Education*, 4(13), 1–16.
- Shulman, L. S. (1986). Those who understand: Knowledge growth in teaching. *Educational Researcher*, 15(2), 4–14. <https://doi.org/10.3102%2F0013189X015002004>

- Shulman, L. S. (1987). Knowledge and teaching: Foundations of the new reform. *Harvard Educational Review*, 57(1), 1–22. <https://doi.org/10.17763/haer.57.1.j463w79r56455411>
- Skamp, K. and Mueller, A. (2001). Student teachers' conceptions about effective elementary science teaching: A longitudinal study. *International Journal of Science Education*, 23(4), 331–351. <https://doi.org/10.1080/09500690119248>
- Timperley, H., Wilson, A., Barrar, H. and Fung, I. (2008). *Teacher Professional Learning and Development*. Wellington, New Zealand: Ministry of Education.
- van Driel, J. H., Meirink, J. A., van Veen, K. and Zwart, R. C. (2012). Current trends and missing links in studies on teacher professional development in science education: A review of design features and quality of research. *Studies in Science Education*, 48(2), 129–160. <https://doi.org/10.1080/03057267.2012.738020>
- Vescio, V., Ross, D. and Adams, A. (2008). A review of research on the impact of professional learning communities on teaching practice and student learning. *Teaching and Teacher Education*, 24(1), 80–91. <https://doi.org/10.1016/j.tate.2007.01.004>
- Williams, P. J., Nguyen, N. and Mangan, J. (2017). Using technology to support science inquiry learning. *Journal of Technology and Science Education*, 7(1), 26–57. <https://doi.org/10.3926/jotse.234>
- Wu, H. and Huang, Y. (2007). Ninth-grade student engagement in teacher-centred and student-centred technology-enhanced learning environments. *Science Education*, 91, 727–749. <https://doi.org/10.1002/sce.20216>
- Yates, G. C. R. and Chandler, M. (2001). Where have all the skeptics gone? Patterns of new age beliefs and anti-scientific attitudes in preservice elementary teachers. *Research in Science Education*, 30(4), 377–387. <https://doi.org/10.1007/BF02461557>
- Yerushalmi, E. and Eylon, B. S. (2013). Supporting teachers who introduce curricular innovations into their classrooms: A problem-solving perspective. *Physical Review Special Topics: Physics Education Research*, 9(1), 010121. <https://doi.org/10.1103/PhysRevSTPER.9.010121>



## A Concrete Proposal to Introduce Control Theory to 16 Year Old Pupils

Leen Goovaerts <sup>1\*</sup>, Mieke De Cock <sup>2</sup>, Katrien Struyven <sup>3,4</sup>, Wim Dehaene <sup>1</sup>

<sup>1</sup> ESAT-MICAS, Faculty of Engineering Science, KU Leuven, Kasteelpark Arenberg 10, 3001 Leuven, BELGIUM

<sup>2</sup> Faculty of Science, Department of Physics and Astronomy, KU Leuven, Celestijnenlaan 200c – bus 2406, 3001 Leuven, BELGIUM

<sup>3</sup> Hasselt University, School for Educational Studies, BELGIUM

<sup>4</sup> Vrije Universiteit Brussel, Educational Sciences Department, BELGIUM

\*Corresponding Author: [leen.goovaerts@kuleuven.be](mailto:leen.goovaerts@kuleuven.be)

**Citation:** Goovaerts, L., De Cock, M., Struyven K. and Dehaene, W. (2019). A Concrete Proposal to Introduce Control Theory to 16 Year Old Pupils. *European Journal of STEM Education*, 4(1), 06. <https://doi.org/10.20897/ejsteme/5757>

**Published:** April 29, 2019

### ABSTRACT

High level, abstract engineering thinking and design is a subject that is hardly addressed in current curricula for secondary education. This is contradictory to the increasing need for more in depth STEM education in secondary schools dictated by the evolution of our society towards an ever more STEM based information society. In this paper an approach is presented to introduce 16 year old Belgian pupils to some of the most important, basic concepts of control theory. Control theory is here exemplary for more general engineering science. The problem used to introduce control theory is that of heating system design in houses.

**Keywords:** STEM education, control engineering, integration

### INTRODUCTION

Bringing more engineering into secondary school, can provide pupils with a better view of the actual meaning of engineering in general. Arising from these better views, pupils will be able to make a more conscious choice regarding their further education (Kelley and Knowles, 2016). Professional and real life engineering is based on scientific grounds. As a consequence, engineering is often perceived as too difficult and too complex for secondary school pupils. Despite of new integrative STEM activities in secondary schools, there is an absence of engineering science in classic secondary education curricula, since only a few have already been successful in applying true engineering. Many initiatives reduce engineering to problem solving or design (Apedoe et al., 2008; Capraro et al., 2013; Daugherty, 2009; Klein and Sherwood, 2005; Lam et al., 2008; Petrosino, 2004). Notwithstanding these aspects are inseparable connected with engineering, they do not cover the engineering science.

We define engineering as a science which integrates science, technology and mathematics, and links concepts of these courses. On top of that, engineering should also focus on the procedural knowledge of problem solving, not by explaining it, but by doing it. This definition is in line with the definitions of engineering of CEAB and ABET, although they additionally mention social and ethical responsibilities, which did not get attention in the definition of engineering in this paper. For instance, the criteria for accrediting engineering programs based on program outcomes and assessment for ABET mention not only the ability to apply knowledge of mathematics, science and engineering, but also the ability to design experiments, systems, components and processes; analysing and interpreting data; identify, formulate and solve engineering problems; use techniques, skills, and modern engineering tools necessary for engineering practice; along with ethical and social reflections and responsibilities (Lattuca et al., 2006). Very similar is the framework about engineering of CEAB (Engineers Canada, 2017). They

also mention applying engineering knowledge, methods, techniques, tools, equipment and technology; as well as social and ethical responsibilities.

The absence in current secondary education of the concepts mentioned above is contradictory to the needs of the modern ‘information society’ where STEM in general and engineering in particular play an even more important role.

The challenge addressed in this paper is to bring some of those, so called complex, engineering topics to a level suitable for secondary school pupils. To accomplish this, the problems addressed need to be broken down to the essential core. In this stripping process, the educational designer must make sure that his underlying goals are obtained. The main underlying goal of bringing engineering to secondary education is to show that engineering is a science on its own, based on other fundamental sciences and calculations. As a science it comes with its own set of rules which need to be applied. The rules of engineering science may show how science and mathematics need to be applied and integrated in an engineering context. When pupils are shown the use of science and mathematics in engineering, and are taught the rules of engineering science, the problems are usually perceived as less complex. Moreover, pupils are able to see the logic steps during the problem solving process.

By integrating science and mathematics into engineering education in secondary school, pupils become aware that engineering is much more than just tinkering. Professional engineering ‘tinkering’ needs to be supported by science concepts and mathematical models.

The challenge to bring engineering to secondary education that is described here, is part of a broader research project. The STEM@school project (Thibaut et al., 2018) aims to develop and validate a learning environment for integrated STEM (Science, Technology, Engineering, Mathematics) education in secondary school and as such contribute to the development of research based STEM education. In order to meet this goal, a framework consisting of five key principles is constructed. These principles have been proven successful in previous studies and frameworks, as indicated below. By combining these ideas, the assumption is that maximal learning gain occurs (Mehalik et al., 2008). The key principles are: integration of different STEM disciplines (Becker and Park, 2011; Capraro et al., 2013; Christiansen and Rump, 2008; Huntley, 1998; James et al., 2000; Lam et al., 2008; Moore and Smith, 2014; Riordáin et al., 2016; Ross and Hogaboam-Gray, 1998; Wicklein and Schell, 1995), problem-centered (Dym et al., 2005) and cooperative learning (Dym et al., 2005; Fosnot and Perry, 1996; Isık and Tarım, 2009), with explicit attention to research and design (Banks and Barlex, 2014; Dym et al., 2005; Mehalik et al., 2008; Wallin et al., 2016), as well as the application of discipline specific educational research results. More information on the project can be found on its website ([www.stematschool.be](http://www.stematschool.be)).

STEM@school encourages pupils to transfer concepts of one specific discipline to another. Therefore, the concepts need to be abstracted into models and applied in a new context or the other way around, in other words, by forward-reaching-high road transfer or backward-reaching high road transfer (Perkins and Salomon, 1988). Perkins and Salomon (1988) describe forward-reaching-high road transfer ‘as one learns something and abstracts it in preparation for applications elsewhere.’ On the contrary, when ‘one finds oneself in a problem situation, abstracts key characteristics from the situation, and reaches backward into one’s experience for matches’ is defined as backward-reaching-high road transfer. So, specific attention in the learning modules for abstracting and model thinking, facilitates transfer, this is why model-thinking, described further in this paper, is crucial for an integrated STEM curriculum.

Control theory, as described below, is a classic part of engineering science (De Laet et al., 2013). In the STEM@school project, an effort was made to make control theory tractable for 16 years old pupils, so it can be introduced in the curriculum of the fourth year of Flemish secondary education (K10). Since control theory needs the knowledge of physics and mathematics, the content knowledge as well as the procedural knowledge, this is a perfect example of integrated STEM education. How this was done, is the subject of this paper. More precisely, the following research questions are addressed:

1. How can you design learning materials on control engineering for 16 year old pupils?
2. How can you teach control engineering to 16 year old pupils?
3. How was the developed learning module implemented in the classroom in Flemish secondary education?

The paper is structured as follows. First, the concept of engineering thinking is explained. Then, the challenge is presented. The following section describes the modelling-based approach of teaching, with the content and engineering topics. The fourth chapter includes the reaction the teachers following an in-service training about control engineering and the reaction of a teacher on the implementation of the developed module. In the last paragraph, a discussion is initiated.

## ENGINEERING THINKING

To stimulate the engineering thinking process in the pupils’ mind, it is important to start from an engineering problem pupils consider a challenge (Burgess, 2004). This challenge needs to be solved by the use of science,

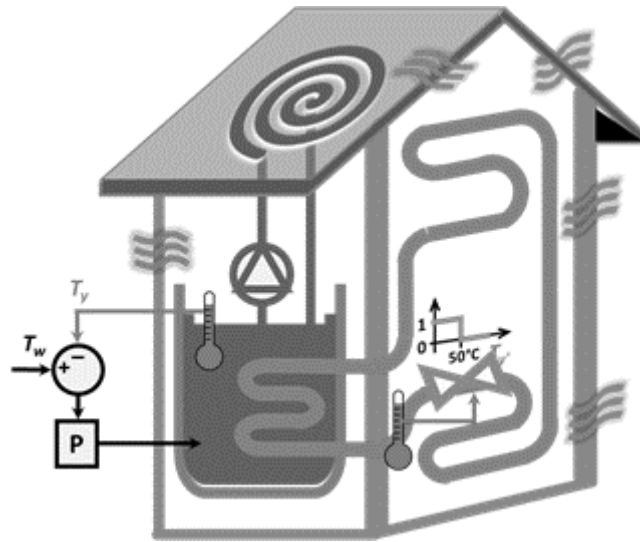

**Figure 1.** Schematic presentation of the challenge of the passive house

mathematics and technology. As such, pupils realise that science and mathematics knowledge is necessary to solve engineering problems in an efficient controlled and reproducible way.

An engineering problem is typically a mechanical or electronic design, the creation of a software program, an optimisation, etc. Both the problem and the solution of the problem typically are modelled with the help of mathematics and science. The modelling of the problem can then be used to predict, validate and dimension the problem and from there, come to a scientifically supported solution. The model of the problem will help pupils to solve the problem, relying on the different aspects in the model.

The mathematical models in engineering are often constructed out of primitive elements that present a well-defined behaviour. These elements are often idealised, neglecting real life, parasitic behaviour (Gainsburg, 2006). A model with only ideal elements becomes an idealized model. This idealized model is the starting point to solve the problem. The model needs to be fine-tuned step by step until it corresponds with the real system. The gradual refinement allows to combine progressive insights in the problem with the development of an increasingly realistic model. It also allows to develop a gradually more complex solution for the problem. This modelling-based strategy will here be adopted to introduce the pupils to control theory.

In engineering design, the developed model of the problem is often presented in equations, graphics and block diagrams. Putting these representations interchangeably next to each other, provides more insight for pupils (Marx, et al., 2004; Merrill, 2002; Petrosino, 2004). Moreover, pupils learn to translate their scientific knowledge into mathematical equations and interpret mathematical graphs with their physical knowledge. This is important because pupils have trouble to make connections between those two (Jasien and Oberem, 2002) and on top of that it helps pupils to make high road transfer (Perkins and Salomon, 1988).

Hassan (2011) claims, it is not sufficient for an (engineering) student to possess knowledge – engineers need to be able to apply their knowledge/skills in situations which they have not encountered before. The frameworks of CEAB (Engineers Canada, 2017) and ABET (Lattuca, Terenzini and Fredericks Volkwein, 2006) also include this necessary application.

## THE CHALLENGE

As described in the introduction, the introduced STEM-course is problem-centred, and different modules start from a real life, engineering problem, related to subject matter that is taught in the related courses.

In the fourth year of Flemish secondary school, where pupils reach the age of 16, one engineering problem that was selected as a driving challenge: ‘Design and develop a passive house with a sun boiler that heats the house. The temperature of the house should be actively controlled.’ This STEM-design challenge is presented in **Figure 1** and elaborated in Goovaerts et al. (2019). The problem is formulated this way, because a lot of learning goals in the established, existing physics curriculum for the fourth year cover thermodynamics. Controlling the temperature is the engineering goal that is strived for in parallel to learning the physics of heat and heat transfer. During the mathematics course, pupils learn about geometric sequences and geometric transformations of functions in order to predict the behaviour of the system.

## MODELLING-BASED APPROACH

In order to make engineering topics suitable for pupils of secondary school, a modelling-based approach is suggested. ‘A model is a simplified representation of a system, which concentrates attention on specific aspects of the system. Moreover, models enable aspects of the system, i.e., objects, events, or ideas which are either complex, or on a different scale to that which is normally perceived, or abstract to be rendered either visible or more readily visible’ (Gobert and Buckley, 2000). Making a model of the problem has two goals: first, making a model helps to understand and analyse the problem. Second, once you found a solution, it can be tested on the model. So, in order to make the problem and control engineering more comprehensible, the control system is modelled and made more complex and realistic step by step. In this way, modelling helps pupils to do problem-solving, because modelling is a first step to problem-solving in engineering science. It is possible to do modelling without problem solving, but not the other way around. Modelling serves problem-solving because it reveals the different aspects present in the system.

A mathematical modelling process, described by Gainsburg (Carberry and McKenna, 2014; Gainsburg, 2006), can be translated to an engineering approach. The modelling process Gainsburg explains, contains the following steps:

1. Identify the real-world phenomenon;
2. Simplify or idealize the phenomenon;
3. Express the idealized phenomenon mathematically;
4. Perform the mathematical manipulations;
5. Interpret the mathematical solution in real-world terms;
6. Test the interpretation against reality.

The proposed mathematical modelling process of Gainsburg can be used as a model itself in order to use it for an engineering purpose. Abstraction can be made of the fact that the process serves mathematics. When this abstraction is made, the modelling process can be used for other purposes. Iteration is missing in the modelling process of Gainsburg, and should be added in any modelling process. When the test against reality is not sufficient, the model needs adaptation and retested again.

In the engineering project, and the corresponding challenge, described in this paper these steps will be incorporated and will be presented throughout this paper. As mentioned before, the end goal of the challenge is to actively control the temperature in the house. In order to reach this goal, pupils need to program the control system. On/off control is presented to the pupils as the control strategy to reduce the complexity of the problem. Before setting up the implementing this system in the house, pupils also have to model and simulate it. The concrete, intermediate goal is thus to let them predict the graph of the temperature, with on/off control system, in a realistic situation. This prediction should, in a next step, match the observations in the corresponding experimental setting. This will be repeated for several idealized versions of the system. Each version will be less idealized than the previous version.

To model and eventually build this kind of control systems, pupils need to acquire a deep insight in the concepts of heat conduction and heat capacity. With this content knowledge, pupils will be able to set up the equations that will predict the behaviour of the system.

### Content

As mentioned before, pupils need to learn about the mathematical and physical content related to the challenge. This content will be taught in the subject courses in parallel with the challenge. Instead of teaching content and skills and hoping students will see the connections to real-life application, an integrated approach seeks to locate connections between STEM subjects and provide a relevant context for learning the content (Kelley and Knowles, 2016; Moore and Smith, 2014). Using engineering design as a catalyst to STEM learning is powerful to bring all four STEM disciplines on an equal platform. An integrated STEM approach should leverage the idea that STEM content should be taught along STEM practices (Kelley and Knowles, 2016).

The content used in this STEM-challenge is chosen because of the mandatory curriculum guidelines. The curriculum guidelines in Flanders precisely prescribe the content for each grade (2 years) of secondary education. The only freedom teachers have, is to decide the order of the topics and the way they teach them. So the curriculum topics of physics and mathematics are aligned in a way that the engineering approach and didactical criteria that were set as criteria are maximally fostered.

In order to solve the challenge of controlling the temperature of the passive house, content from different courses needs to be addressed and brought together. This multidisciplinary is also necessary for a high quality STEM education. **Table 1** summarizes the content from the separate courses that is needed.

**Table 1.** Content needed to complete the challenge

Physics content	Mathematics content	Engineering content
Heat capacity (Analogy with capacitance in electricity)	Geometric sequence: Recursive and explicit equations	Integration of science, mathematics and technology
Thermal resistance (Analogy with resistance in electricity)	Transformations of functions	Mathematical model for the time-behaviour of a system

**Table 2.** Physics content

Equations	Parameters
<p>The power to heat everything inside the house, can be calculated as follows:</p> $P = \frac{Q}{\Delta t} = \frac{m \cdot c \cdot (T_{end} - T_{begin})}{\Delta t} = \frac{c \cdot (T_{end} - T_{begin})}{\Delta t}$	<p><math>m = \text{mass [kg]}</math>  <math>c = \text{specific heat capacity } \left[ \frac{J}{kg \cdot ^\circ C} \right]</math>  <math>T_{end} = \text{temperature at the end } [^\circ C]</math>  <math>T_{begin} = \text{temperature in the beginning } [^\circ C]</math>  <math>\Delta t = \text{time necessary to go from the beginning to the end temperature [s]}</math>  <math>P = \text{power [W]}</math></p>
<p>The leak power through the walls, doors and windows, can be calculated as follows:</p> $P_{leak} = \frac{S \cdot k}{d} (T_{inside} - T_{outside}) = \frac{(T_{inside} - T_{outside})}{R_{th}}$	<p><math>S = \text{surface [m}^2]</math>  <math>k = \text{thermal conductivity coefficient } \left[ \frac{W}{m \cdot ^\circ C} \right]</math>  <math>d = \text{thickness [m]}</math>  <math>T_{inside} = \text{temperature inside the house } [^\circ C]</math>  <math>T_{outside} = \text{temperature outside the house } [^\circ C]</math>  <math>P_{leak} = \text{leak power [W]}</math></p>

**Table 3.** Mathematics content

Equations	Parameters
Straight line: $y = m \cdot x + b$	<p><math>m = \text{slope}</math>  <math>b = \text{intercept}</math></p>
<p>Recursive formula of geometric sequence terms: <math>u_n = u_{n-1} \cdot q</math>                      Explicit formula of geometric sequence terms: <math>u_n = u_1 \cdot q^{n-1}</math></p>	<p><math>u_n = n^{th} \text{ term of the geometric sequence}</math>  <math>q = \text{the multiplier of the geometric sequence}</math>  <math>u_1 = \text{first term of the geometric sequence}</math></p>
Sum of the terms of a geometric sequence: $s_n = u_1 \cdot \frac{q^n - 1}{q - 1}$	<p><math>s_n = \text{sum of the geometric sequence}</math>  <math>u_1 = \text{first term of the geometric sequence}</math>  <math>q = \text{the multiplier of the geometric sequence}</math></p>

Ideally, all different courses refer back to the challenge in their lessons and point the pupils to the integration of the different subjects (Kelley and Knowles, 2016). A crucial factor is therefore that the content in these different courses is aligned. It is necessary for pupils to see the mutual relevance of learning topics in different courses. If pupils implement their new learned knowledge immediately, they will come to a better understanding of the material (Berland, 2013).

The content needed to tackle the challenge is described in what follows, both for physics (Table 2) and mathematics (Table 3). The content is mentioned here, because it plays a big role in the simulation and predictions that the pupils will need to make.

This challenge is in se an engineering challenge, but addressing it in the way we present, it becomes an integrated challenge. As such, it creates learning opportunities for all STEM-disciplines.

**Generic Block Diagram**

When people start solving a problem, they construct a model of how they might approach the problem, in their minds and sometimes in a tangible form like a drawing. These models, whether arrived at deliberately or with little forethought, will guide the steps people take to solve it (Kober, 2015). Block diagrams are a typical example of a model used in control engineering. Therefore, in order to help pupils make a correct and helpful model, the construct of block diagrams is introduced.

For students to communicate conversantly in a discipline, they need to be able to interpret and use the major types of representations of that discipline. Just as importantly, they need to understand the concept a particular representation is intended to convey and know why both the representation and the underlying concept are important (Kober, 2015). Since models are a language used by engineers to enhance their engineering design



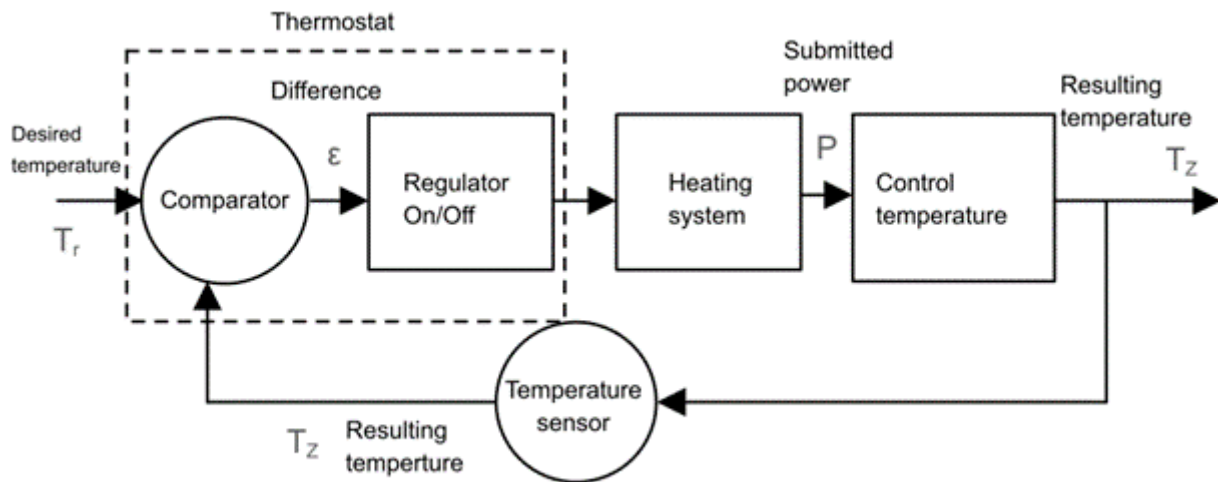

**Figure 2.** Block diagram of the temperature control system

process and their computational understanding of a problem (Carberry and McKenna, 2014) and block diagrams are an important way of modelling for engineers, teaching block diagrams is a crucial part of teaching control engineering. This is supported by Carberry and McKenna (2014) when they claim: ‘When modelling is made explicit to students, they obtain a clearer understanding of model-based reasoning in engineering design.’

As mentioned before in the model of Gainsburg (2006), an important step in almost all the models, that describe modelling, is the translation of the verbal problem description, first into a graphic representation and then into a mathematical representation. This step is known as representational transformation. Pupils have been found to frequently go straight to a mathematical formula without creating the visual representation of the problem, while making visualizations is integral to scientific thinking (Ainsworth et al., 2011). This usually results in failure or misapplication of a formula leading to a dead-end (Svinicki, 2011).

Contrastingly, experts spend more time analysing the nature of a problem from the outset and creating a coherent solution strategy, while novices often jump immediately to the end goal of a problem and start looking for an equation that might help them solve it (Kober, 2015; Mevarech and Kramarski, 2014). Experts go on to enrich their model of the problem with information from what they know and remember. In this working forward approach, they start with the information given, making inferences based on that information, and continue refining their inferences until they have reached their goal (Kober, 2015). This building up, is exactly what teachers should teach their pupils. In the case of control engineering, first a general block diagram is constructed. The next step is to incorporate specific signals to make the problem more concrete. In the last step, mathematical equations that express the physical phenomena will be added.

Almost any control system can be presented in a general block diagram, as shown in **Figure 2**. A block diagram gives a good overview of which parts need to be connected with each other and what needs to be compared. Drawing a block diagram is a necessary skill in engineering, therefore pupils should be able to use and interpret this representation. Just as importantly, they need to understand the concept a particular representation is intended to convey and know why both the representation and the underlying concept are important (Kober, 2015).

As can be seen in **Figure 2**, an on/off control system is chosen. This has a triple motivation. First of all, this is also how a realistic heating system in a normal house works. Secondly, it is important to teach the basics of control engineering to the pupils and the basics of control engineering is an on/off system. By discussing the basics in depth, we hope to build solid fundamentals. A continuous time PID control system is the logical next step, but only after a great insight in the basic control system is acquired. Thirdly, an on/off control system is more easily to model mathematically. PID includes integrals and derivatives, what makes it too hard for the fourth year in secondary school.

The block diagram presented in **Figure 2**, can be interpreted as follows. The comparator constantly compares the desired temperature ( $T_r$ ) with the resulting temperature ( $T_z$ ). When those are not equal, a difference ( $\epsilon$ ) occurs. When the difference differs from zero, the regulator puts the heating system on. This means the maximal power ( $P$ ) is submitted in order to raise the resulting temperature ( $T_z$ ). When the difference has reached zero, the regulator.

Once the general problem and corresponding block diagram is understood, the next step is to build a more detailed version, presented in **Figure 3**. This version of the block diagram introduces the step function and step response of the system. These are key concepts in control theory. In this challenge, the step function is raising the desired temperature and the step response is the evolution of the temperature in the house. Also the different signals between the processes are made clear in this version of the block diagram.



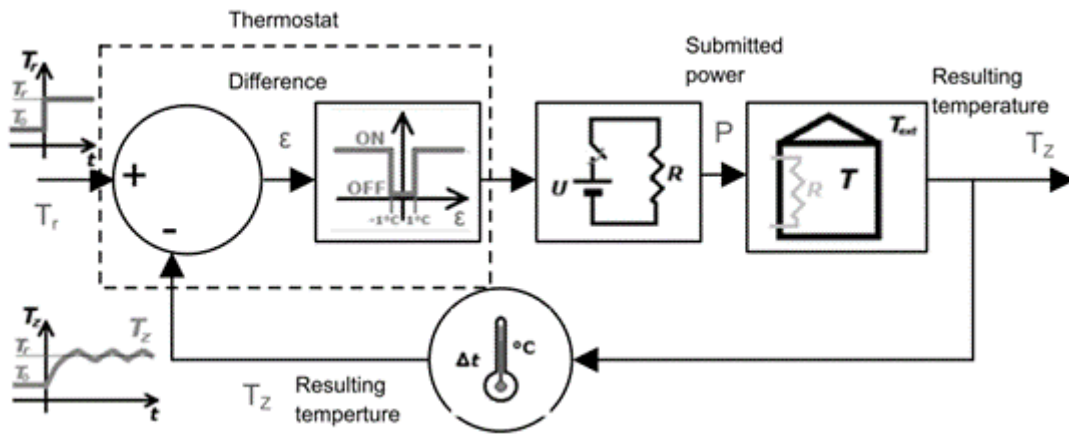

Figure 3. Detailed block diagram

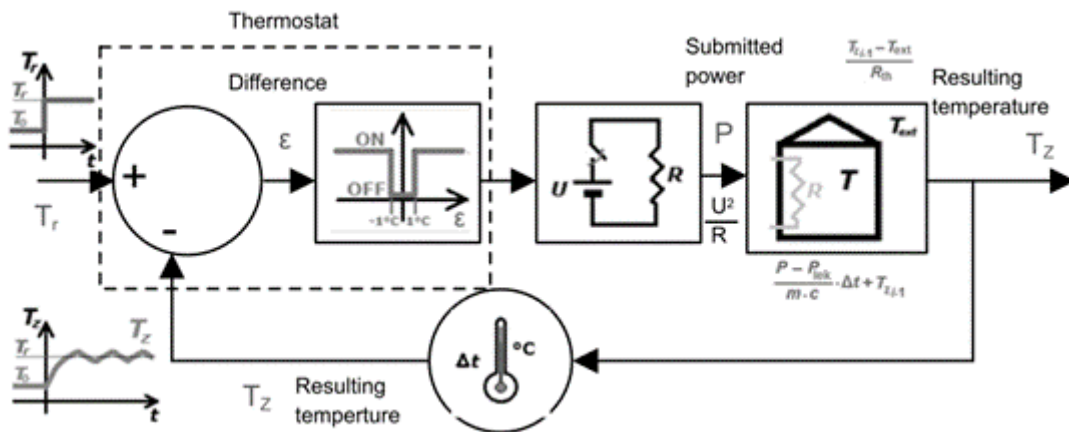

Figure 4. Detailed block diagram with formulas

When this block diagram is made more scientific and mathematical, by adding the physical formulas, pupils will have an even greater advantage when using the block scheme, see Figure 4. The block diagram has become a summary of the knowledge needed to solve the control problem.

With the problem described here it would be possible to introduce the block diagram presented in Figure 4 from the beginning and then strip and simplify this diagram in order to model and solve the control problem mathematically. This approach implies that the teacher immediately gives and discusses this block diagram with the pupils. This is however only possible when the complexity of the problem at hand is limited. Therefore we adopt another, more general, option. The starting point is a block diagram with all losses neglected, this means  $P_{leak}$  will be zero. The next step is to assume the loss is a constant factor. In the final step, pupils receive the block diagram as presented in Figure 4. This last approach is described in the paragraph of ‘Gradual refinement of the model’ in more detail.

This block diagram indicates that a good knowledge of physics is required to solve the challenge. When interpreting this block diagram in a correct manner, pupils can make the correct predictions and simulation of the behaviour of the system under study. Pupils learn that a good block diagram leads to the solution, because it captures the essentials of the system’s functioning. When they follow the arrows on the block diagram, they know how they need to program the control system.

### Using the Model in Simulations

Modelling with pupils and discussing the shortcomings of the model afterwards provides great insights for the pupils about the matter (Carberry and McKenna, 2014). In this paragraph, the modelling and simulations handle the constraints and simplifications of the real-world phenomenon, which is a necessary step, according to Gainsburg (2006).

Pupils will model the heating of a house as a first order system. The inertia is heating the house. This means that the inertia of the heating element is neglected. It’s impossible to heat the house in one second, therefore a delay occurs. According to the model of Gainsburg (2006), the designed model needs to be tested against reality. In the case of this challenge, pupils need to perform experiments, for each model they research. While doing the experiments, pupils will notice that the house keeps on heating when the heating is switched off. This can be

**Table 4.** Gradual refinement of the model

Case	Assumptions
First case	No heat losses through the walls of the house: $P_{leak} = 0$
Second case	Constant heat loss through the walls of the house: $P_{leak} = a \text{ constant}$
Realistic case	Heat losses through the walls of the house depend on the temperature difference between in- and outside the house: $P_{leak} = \frac{S \cdot k}{d} (T_{inside} - T_{outside})$

explained by the inertia of the heating element. We chose to model the system as a first order because a second order is not manageable for pupils to solve the calculations with their current knowledge. Another argument to model the situation as a first order is that in reality, every process is from infinite order. Pupils need to learn to handle with simplifications as a finite order.

### Gradual Refinement of the Model

We guide pupils to a realistic situation by first handling two cases with simplified, idealized assumptions, as mentioned in the engineering thinking process. **Table 4** gives an overview of the different assumptions while refining the model.

For all cases, pupils need to predict the open loop and closed loop step response of the system. Further on, pupils should be asked to compare the slope angles in the different cases. In this way, they are forced to use a mathematical concept in a physics and engineering context.

By comparing their prediction with the results of the experiments, pupils can adjust the parameters in the model where necessary, to become a model that better represents their own heating system.

When discussion the realistic case with pupils, it is possible to use a simulation in Excel, since the necessary formulas are recursive. Though, it is also possible to challenge the pupils to make an explicit formula out of the recursive one, using their own knowledge of geometric sequence and transformations.

## IMPLEMENTATION OF MODULE

Since the anxiety of the teachers towards implementing new things in classrooms remains a struggle to actually implement new things, the authors provided some in-service teacher training about the concept of on-off control engineering. Teachers were guided through the module, as they were the pupils. We discussed a lot of conceptual questions with the teachers and provided background information as well as argumentation why concepts can be taught that way. Also some demonstrations of the simulations and experiments were part of the training. Afterwards teachers were asked to fill in a questionnaire. Exemplary questions are: After this training, do you deem it possible to teach these concepts in the fourth year (K10) of secondary education? Would you feel competent to teach these concepts? Although most teachers were very sceptic about the learning module by the start of this training, afterwards, they all deemed it possible to teach this module to pupils in the fourth year (K10) of Flemish secondary education. Most teachers also indicate they feel competent to teach the discussed concepts after the training. Though, they all would like to have some more time to get familiar with the concepts.

Despite the efforts of the authors to train the teachers, only a few teachers implemented the module of control engineering. This is due to time and regulation issues in Flemish secondary education. Therefore, we only present qualitative data of an interview with one of the implementing teachers. This teacher tackled the module by first adapting the language from the module, into a more appropriate level for pupils. The module is developed for K10 pupils, but the teacher wanted to use the module in K9. Therefore, she decided it is necessary to adapt the level of language. Then she taught the theoretical part of the module. Thirdly, she challenged the pupils to do some reverse engineering, by disassembling a flatiron, in which they had to search for the control loops. Finally, the teacher did a demo-experiment using the different models and predictions of the temperature. The teacher had the impression that the pupils found these concepts interesting, especially when links with reality and other courses were made in the exercises or experiments. In the future, she wants to integrate more mathematics, for example predicting the temperature evolution, which was now only demonstrated and not calculated by the pupils.

## CONCLUSION

This paper describes a way to introduce 16 year old pupils to high level engineering design. In their engineering design, the pupils use the physics and mathematical knowledge that is introduced in parallel and integrate it. On top of that, model thinking, abstracting processes, simulating and manipulating behaviour of a system is introduced to solve the engineering problem. When involving science and mathematics in engineering modelling, pupils are

shown that control theory is part of engineering science which is employed to solve engineering problems in a logical manner.

To build this model systematically, a gradual refinement is necessary. In the first step of the refinement, the different elements will be seen as ideal, in this concrete case, e.g. heat loss is neglected. This makes it manageable for pupils to model and simulate the process and leads to progressing insight. The gradual refinement itself makes the model step by step more realistic. In this concrete case the heat loss go from zero over constant to temperature dependent.

The course content integrated in this control problem is: geometric sequences, geometric transformations of functions, functions, heat capacity and heat conductivity. The latter topic is a retake from the previous school year. The other topics are all topics that need to be taught in the 4<sup>th</sup> year of secondary schools in Flanders.

The whole idea, concepts and elaboration presented in this paper, will be implemented by the secondary schools of Flanders who are involved in the STEM@school project ([www.stematschool.be](http://www.stematschool.be)). This implementation will make clear which adaptations are necessary in order to reach full understanding by 16 year old pupils about the concept of on/off control theory and to let them optimally set their first steps in the world of high level engineering design.

## ACKNOWLEDGEMENTS

The work described in this paper is founded by Flemish government under the IWT-SBO project STEM@school. A special thank you to Jolien De Meester for providing the illustrations in this paper.

## REFERENCES

- Ainsworth, S., Prain, V. and Tytler, R. (2011). Drawing to learn in science. *Science*, 1096-1097. <https://doi.org/10.1126/science.1204153>
- Apedoe, X. S., Reynolds, B., Ellefson, M. R. and Schunn, C. D. (2008). Bringing engineering design into high school science classrooms: The heating/cooling unit. *Journal of Science Education and Technology*, 17(5), 454-465. <https://doi.org/10.1007/s10956-008-9114-6>
- Banks, F. and Barlex, D. (2014). Teaching STEM in the secondary school: Helping teachers meet the challenge. Routledge. <https://doi.org/10.4324/9780203809921>
- Becker, K. and Park, K. (2011). Effects of integrative approaches among science, technology, engineering, and mathematics (STEM) subjects on students' learning: a preliminary meta-analysis. *Journal of STEM Education*, 23-37.
- Berland, L. K. (2013). Designing for STEM integration. *Journal of pre-college engineering education research*, 22-31 <https://doi.org/10.7771/2157-9288.1078>
- Burgess, K. L. (2004). Is your case a problem? *Journal of STEM Education*, 42-44.
- Capraro, R. M., Capraro, M. M., and Morgan, J. R. (2013). *STEM project-based learning: an integrated science, technology, engineering and mathematics approach*. Rotterdam: Sense Publishers. <https://doi.org/10.1007/978-94-6209-143-6>
- Carberry, A. R. and McKenna, A. F. (2014). Exploring students conceptions of modeling and modeling uses in engineering design. *Journal of Engineering Education*, 77-91. <https://doi.org/10.1002/jee.20033>
- Christiansen, F. V. and Rump, C. (2008). Three conceptions of thermodynamics: Technical matrices in science and engineering. *Research in Science Education*, 545-546. <https://doi.org/10.1007/s11165-007-9061-x>
- Daugherty, J. L. (2009). Engineering professional development design for secondary school teachers: A multiple case study. <https://doi.org/10.21061/jte.v21i1.a.1>
- De Laet, T., Boegli, M., Zavari, K. and De Schutter, J. (2013). Conceptual learning of control and state estimation through a mobile cart project. 41st SEFI Conference; 2013; pp. 1 - 8
- Dym, C. L., Agogino, A. M., Eris, O., Frey, D. D. and Leifer, L. J. (2005). Engineering design thinking, teaching, and learning. *Journal of Engineering Education*, 103-120. <https://doi.org/10.1002/j.2168-9830.2005.tb00832.x>
- Engineers Canada. (2017). *Guideline on admission to the practice of engineering in Canada* (Rep.).
- Fosnot, C. T. and Perry, R. S. (1996). Constructivism: A psychological theory of learning. In *Constructivism: Theory, perspectives, and practice* (pp. 8-33).
- Gainsburg, J. (2006). The mathematical modeling of structural engineers. *Mathematical Thinking and Learning*, 3-36. [https://doi.org/10.1207/s15327833mtl0801\\_2](https://doi.org/10.1207/s15327833mtl0801_2)
- Gobert, J. D. and Buckley, B. C. (2000). Introduction to model-based teaching and learning in science education. *International Journal of Science Education*, 22(9), 891-894. <https://doi.org/10.1080/095006900416839>

- Goovaerts, L., De Cock, M., Struyven, K., & Dehaene, W. (2019). Developing a Module to Teach Thermodynamics in an Integrated Way to 16 Year Old Pupils. *European Journal of STEM Education*, 4(1), 02. <https://doi.org/10.20897/ejsteme/3964>
- Hassan, O. A. (2011). Learning theories and assessment methodologies - an engineering educational perspective. *European Journal of Engineering Education*, 327-339. <https://doi.org/10.1080/03043797.2011.591486>
- Heil, D., Pearson, G. and Burger, S. (2013). Understanding integrated stem education: Report on a national study. Atlanta. American Society for Engineering Education.
- Huntley, M. A. (1998). Design and implementation of a framework for defining integrated mathematics and science education. *School Science and Mathematics*, 320-327. <https://doi.org/10.1111/j.1949-8594.1998.tb17427.x>
- Isik, D. and Tarim, K. (2009). The effects of the cooperative learning method supported by multiple intelligence theory on Turkish elementary students' mathematics achievement. *Asia Pacific Education Review*, 465-474. <https://doi.org/10.1007/s12564-009-9049-5>
- James, R. K., Lamb, C. E., Householder, D. L. and Bailey, M. A. (2000). Integrating science, mathematics, and technology in middle technology-rich environments: a study of implementation and change. *School Science and Mathematics*, 27-35. <https://doi.org/10.1111/j.1949-8594.2000.tb17317.x>
- Jasien, P. G. and Oberem, G. E. (2002). Understanding of elementary concepts in heat and temperature among college students and K-12 teachers. *Journal of Chemical Education*, 889-895. <https://doi.org/10.1021/ed079p889>
- Kelley, T. R. and Knowles, J. G. (2016). A conceptual framework for integrated STEM education. *International Journal of STEM Education*, 1-11. <https://doi.org/10.1186/s40594-016-0046-z>
- Klein, S. S. and Sherwood, R. D. (2005). Biomedical engineering and cognitive science as the basis for secondary science curriculum development: a 3 year study. *School Science and Mathematics*, 384-401. <https://doi.org/10.1111/j.1949-8594.2005.tb18059.x>
- Kober, N. (2015). *Reaching students: What research says about effective instruction in undergraduate science and engineering*. Washington DC: Teh National Academies Press.
- Lam, P., Doverspike, D., Zhao, J., Zhe, J. and Menzemer, C. (2008). An evaluation of a STEM program for middle school students on learning disability related IEPs. *Journal of STEM Education*, 21-29.
- Lattuca, L. R., Terenzini, P. T. and Fredericks Volkwein, J. (2006). *Engineering change: A study of the impact of EC2000* (Rep.). United States of America: ABET. Retrieved from <https://www.abet.org/wp-content/uploads/2015/04/EngineeringChange-executive-summary.pdf>
- Marx, R. W., Blumenfeld, P. C., Krajcik, J. S., Fishman, B., Soloway, E., Geier, R. and Tal, R. T. (2004). Inquiry-based science in the middel grades: assessment of learning in urban systemic reform. *Journal of Research in Science Teaching*, 1063-1080. <https://doi.org/10.1002/tea.20039>
- Mehalik, M. M., Doppelt, Y. and Schuun, C. D. (2008). Middle-school science through design-based learning versus scripted inquiry: better overall science concept learning and equity gap reduction. *Journal of Engineering Education*, 71-85. <https://doi.org/10.1002/j.2168-9830.2008.tb00955.x>
- Merrill, D. M. (2002). First principles of instruction. *Educational Technology Research and Development*, 43-59. <https://doi.org/10.1007/BF02505024>
- Mevarech, Z. and Kramarski, B. (2014). *Critical maths for innovative societies: the role of metacognitive pedagogies*. OECD Publishing. <https://doi.org/10.1787/9789264223561-en>
- Moore, T. J. and Smith, K. A. (2014). Advancing the state of the art of STEM integration. *Journal of STEM Education*, 5-10.
- Perkins, D. N. and Salomon, G. (1988). Teaching for transfer. *Educational Leadership*, 22-32.
- Petrosino, A. J. (2004). Integrating curriculum, instruction, and assessment in project-based instruction: a case study of an experienced teacher. *Journal of Science Education and Technology*, 447-460. <https://doi.org/10.1007/s10956-004-1466-y>
- Riordáin, M. N., Johnston, J. and Walshe, G. (2016). Making mathematics and science integration happen: key aspects of practice. *International Journal of Mathematical Education in Science and Technology*, 233-255. <https://doi.org/10.1080/0020739X.2015.1078001>
- Ross, J. A. and Hogaboam-Gray, A. (1998). Integrating mathematics, science, and technology: effects on students. *International Journal of Science Education*, 1119-1135. <https://doi.org/10.1080/0950069980200908>
- Shepard, L. A. (2000). The role of assessment in a learning culture. *Educational researcher*, 4-14. <https://doi.org/10.3102/0013189X029007004>
- Svinicki, M. D. (2011). Synthesis of the research on teaching and learning in engineering since the implementation of ABET engineering criteria 2000. *Second Committee Meeting on the Status, Contributions, and Future Directions of Discipline-Based Education Research*. Washington DC: National Academies.
- Thibaut, L., Ceuppens, S., De Loof, H., De Meester, J., Goovaerts, L., Struyf, A., . . . others (2018). Integrated stem education: A systematic review of instructional practices in secondary education. *European Journal of STEM Education*. <https://doi.org/10.20897/ejsteme/85525>

- Wallin, P., Adawi, T. and Gold, J. (2017). Linking teaching and research in an undergraduate course and exploring student learning experiences. *European Journal of Engineering Education*, 58-74. <https://doi.org/10.1080/03043797.2016.1193125>
- Wicklein, R. C. and Schell, J. W. (1995). Case studies of multidisciplinary approaches to integrating mathematics, science and technology education. *Journal of Technology Education*. <https://doi.org/10.21061/jte.v6i2.a.5>



<http://www.lectitopublishing.nl>



<https://www.facebook.com/LectitoJournals/>



<https://twitter.com/lectito1>



<https://www.linkedin.com/in/lectito-journals-9a675010b/>



## Revisiting Second Graders' Robotics with an Understand/Use-Modify-Create (U<sup>2</sup>MC) Strategy

Youngkyun Baek <sup>1\*</sup>, Sasha Wang <sup>1</sup>, Dazhi Yang <sup>1</sup>, Yu-Hui Ching <sup>1</sup>, Steve Swanson <sup>1</sup>, Bhaskar Chittoori <sup>1</sup>

<sup>1</sup> Boise State University, USA

\*Corresponding Author: [youngkyunbaek@boisestate.edu](mailto:youngkyunbaek@boisestate.edu)

**Citation:** Baek, Y., Wang, S., Yang, D., Ching, Y.-H., Swanson, S. and Chittoori, B. (2019). Revisiting Second Graders' Robotics with an Understand/Use-Modify-Create (U<sup>2</sup>MC) Strategy. *European Journal of STEM Education*, 4(1), 07. <https://doi.org/10.20897/ejsteme/5772>

**Published:** May 11, 2019

### ABSTRACT

This study, a sub-study of a National Science Foundation (NSF) funded research project, applies a modified strategy of the U<sup>2</sup>MC for an eight-week afterschool robotics curriculum to promote upper elementary students' computational thinking in the second grade. Twenty-one students in second grade participated in a Life on Mars project which lasted for ten days with one class hour per day. They participated in activities learning coding concepts, basics of robotics, as well as exploring life on Mars. Most notably, the study found a significant increase in participants' computational thinking skills. In addition, participants came to understand basic robotics, including operation, composites, and codes. Implications for future research and robotics curriculum design are discussed in the presentation.

**Keywords:** robotics, computational thinking, Use-Modify-Create approach, coding, STEM+C

### COMPUTATIONAL THINKING AT ELEMENTARY GRADES

As computing becomes a routine but vital skill for everyone in today's society, educators realize that computer knowledge and skills are indispensable for future success. However, due to the ever-changing characteristics of computer knowledge and skills, this perspective soon shifts focus from knowledge and skills (which quickly become obsolete) to the thinking processes that govern computing tasks. Understanding the principle thinking processes is the key factor that would allow today's students to thrive in a future that is heavily influenced by computing (Yadav et al., 2014). Computational thinking is a process very similar to that of how computers operate. Computing refers to the parallel process the human brain takes in processing information, which aligns similarly to how computers function. Therefore, computational thinking is a process where human cognition behaves similarly to a computer. It is defined as a mental process involving these activities under each corresponding concept (Wing, 2006; 2008). Computational thinking draws on the above-mentioned concepts such as logic, algorithms, decomposition, abstraction, pattern recognition and generalization, and evaluation. Each concept systematically and efficiently processes information and tasks, and are fundamental steps in computer science (Lee et al., 2011). This involves logic as a mechanism for prediction and analysis (Ruggieri, 2000), making steps and rules characterized by algorithms, breaking down the whole into parts i.e., decomposition, removing unnecessary details which can be called an abstraction, spotting and using similarities to recognize patterns and drawing generalizations, and lastly making judgments for evaluation (Barr and Stephenson, 2011).

Because computational thinking is considered a prerequisite skill for many endeavors of the 21st century (Barr and Stephenson, 2011; Committee for the Workshops on Computational Thinking, 2010; Johnson et al., 2014; Wing, 2008; Yadav et al., 2014), educators have been developing curricula which integrate specific computational

thinking skills, such as logical and algorithmic thinking (Barr and Stephenson, 2011; Johnson et al., 2014; Sullivan and Heffernan, 2016; Tran, 2018; Voogt et al., 2015; Weintrop et al., 2016). The primary goal of teaching computational thinking in schools is to develop students' ability to solve problems and express the solution in the form of an algorithm that enables the use a computer and other tools to assist in the solution. This approach to teaching computational thinking in schools is supported by The Computer Science Teachers Association (CSTA, 2011), Committee for the Workshops on Computational Thinking (2010), The Royal Society (2012), and Hemmendinger (2010). The integration of computational thinking into K-12 subjects has been mostly implemented in computer-related subjects such as computing and robotics, and other STEM (Science, Technology, Engineering, and Math) areas. While there already exists an implementation of computational thinking in the computing curriculum as a separate subject in the UK (Royal Society, 2012), the need to link computational thinking to subjects other than computer science has been argued by Wing (2006), Hemmendinger (2010), Voogt et al. (2015) and Fathi and Hildreth (2017). Currently, this approach to integration is mostly at the secondary level (ET 2020 Working Group on Digital Skills and Competencies, 2016), but the literature indicates an increasing trend to introduce it in primary education (Dasgupta et al., 2017).

On the Computational Thinking Vocabulary and Progression Chart created by ISTE and CSTA (2011), nine computational thinking vocabulary words/sets are presented for grade levels from Pre-K to 12th grade. It is not surprising to see activities for grades PreK to second are listed across all computational thinking vocabulary words. Learning experiences for PreK to second grade in language arts, geometry, literature, computer science, science, and social studies are exemplified. Even though ISTE and CSTA recommend cross-curricular activities for learning computational thinking, most practices were implemented around STEM subjects.

Chen et al (2017) organized a robotics curriculum around specific topics that control basic movements, voice recognition, tactile sensors, and various other robotics-related skills and tasks. Furthermore, the researchers included several key computer science concepts such as algorithms, variables, conditionals, loops, serial execution, and multitasking. Their participants followed three steps: writing a program on a piece of paper, testing it on a virtual robot, and running the tested program on a physical robot. They found that the devised activities in the curriculum improved students' computational thinking, especially in the context of robotics programming. As in this case of Chen et al. (2017), robotics is assumed as an interdisciplinary subject which can be used to integrate and practice computational thinking as it incorporates computer science and STEM concepts, systems, and technologies (Shoop et al., 2016).

Children as young as four can learn computational thinking concepts and robotics with assembling and programming (Grover and Pea, 2013). Kazakoff, Sullivan, and Baratè (2013) found that children's sequencing skills improved significantly from pre- to post-test after participating in a one-week intensive robotics and programming workshop. Bers, Flannery, Kazakoff and Sullivan (2014) demonstrated that kindergartners were both interested in and able to learn many aspects of robotics, programming, and computational thinking with the *TangibleK* curriculum design incorporating robot construction, programming concepts and debugging. In an attempt to replace the old curriculum with new robotics activities, Elkin, Sullivan, and Bers (2014) implemented a robotics curriculum which they integrated within a social science unit in a mixed-age Montessori classroom. The curriculum, which emulates the qualities of Montessori manipulatives, offers a unique way for children to interface with new concepts and perspectives through a lens customized to their past learning experiences. This study is one example of using robotics uniquely as a tool to provide enriching learning experiences for children, while still achieving programming skills and developing computational thinking skills.

Dasgupta et al. (2017) provided evidence of kindergarten students' engagement with computational thinking through analysis of their work focused on pattern recognition. They report that pattern recognition in a single direction is a developmentally appropriate skill for these kindergarten students; however, pattern recognition in two directions, both horizontally and vertically, was not commonly seen. It is challenging to introduce computational thinking into young students' activities due to their limited advanced cognitive skills, their complex learning environment, and cross-subject curriculum.

Baratè, Ludovico, and Malchiodi (2017) organized music notation activities with Lego blocks for elementary students. Characteristics of blocks such as shape, color, and position over the board were reconfigured to support multiple and heterogeneous encodings of a music score. Each block was used to have musical meaning. As a result, they could create a suitable learning framework which can improve music skills and, at the same time, can convey computational thinking concepts. Sullivan and Bers (2016) demonstrated that as early as pre-kindergarten, children were able to master foundational concepts regarding programming a robot, and that children as young as seven years old were able to master concepts as complex as programming a robot using conditional statements. Their curriculum was organized around knowledge of robots, robot construction, and programming a robot with conditional statements. In the study with five to six-year-old children, Lieto et al (2017) found a significant effect of educational robotics on robot programming skills after 13 training sessions of 75 minutes each, while incorporating hands-on experiences. They reported a short-term beneficial effect of robotics as demonstrated in

the previous studies of Kazakoff et al. (2013) and Sullivan and Bers (2016). That is, they found that children learned to wait and check robot's moves and goals before relying on their behavioral control. As these studies have shown, educators can incorporate computational thinking skills early on in a grade-school curriculum to maximize learning potential across the years. It is important to note that separating the teaching method from the curriculum in robotics practices can be challenging. This is especially true in elementary grades where developmentally-appropriate and cross-curricular practices are not fully defined and identified (Dasgupta et al., 2017).

This study took the first implementation that utilized project-based learning, integrating a science topic, Life on Mars, with programming a robot into a second grade classroom. The Life on Mars project, based on scientific inquiry, was centered on designing robots and testing them on a simulated Mars environment in fourth and fifth-grade classrooms. In this project, students learned how to incorporate related science and engineering concepts into the designing of robots using Mindstorms EV3 Legos. The first implementation of this curriculum demonstrated that participating students and teachers enjoyed the afterschool STEM+C robotics program and the curriculum fostered students' development of computational thinking and positive attitudes toward science (Yang et al., 2018). However, the project-based learning approach used to develop students' programming concepts and computational thinking skills did not adequately prepare students to connect their learned knowledge and skills when tackling the problems in the final competition (Ching et al., 2018). Thus, this study adopted a modified strategy of the Understand/Use-Modify-Create to identify its effects on second grader's computational thinking skills.

## STRATEGIES FOR PROMOTING COMPUTATIONAL THINKING IN ELEMENTARY EDUCATION

There are many ways to integrate computing education into existing curriculum in elementary education, especially as teaching computational thinking skills has taken various forms in its practice. Accordingly, the resources to support this emerging area in school curriculum continue to grow and become ever-more diverse. However, there is no denial that computational thinking integration into students' activities has been frequent in the subjects of computing and STEM (Science, Technology, Engineering, and Math). Traditionally, computing and STEM were the main subjects which dealt with the computational thinking skills of students. Recently it has begun expanding to other subjects such as the arts, reading, and music. Furthermore, cross-curricular activities to teach computational thinking has become a significant trend in elementary education (Tran, 2018). Ways of teaching and learning computational thinking skills are diverse, ranging from linear progressive strategies where a teacher leads the educative process of teaching computing to project-based, explorative inquiries where a student leads the process of learning computational thinking skills. Research and subsequent practices showing strategies in teaching computational thinking skills are grouped into four categories and introduced in the following paragraphs.

### Manipulating Embodied Objects

In the context of problem-solving strategies as Lye and Koh (2014), and Butler et al. (2015) used a guided strategy, *divide and conquer*, which is a top-down deconstruction of building a castle in Scratch. Another similar strategy applied by Jörg et al (2014) for the purpose of teaching fifth and sixth graders computational thinking in order to increase the proportion of minorities and, specifically women in computing, was a step by step choreographed character animation. Baratè et al. (2017) used bricks, properly placed over a building baseplate to represent music scores in their study, which fostered computational thinking in elementary school children through LEGO-based music notation.

In the study performed by Good et al (2008), students ages 12 to 13 were engaged and motivated toward learning computational thinking using an embodied interface. The students in their study could take on the role of a character and organize the characters' movements into sequences so that the recorded movements could be manipulated in ways that fostered computational thinking. The hands-on activities with manipulatives seem to promote the decomposition skill, one of the computational thinking skills, as manifested by the study of Li, Hu, and Wu (2016), arguing that drawing geometric figures among the three hands-on activities was helpful in learning when the participants felt bored. One of the contributions of Good et al. (2008) and Li et al. (2016) was their addition of motivation and engagement in promoting computational thinking. Their *Unplugged and Embodied* games, together with the board games of Tsarava, Moeller, & Ninaus (2018), are examples of materialized physical manipulatives for elementary students to play with algorithmic thinking, abstraction, pattern recognition, and decomposition. The U<sup>2</sup>MC strategy in this study includes activities manipulating embodied objects, that is, participants used their arms, legs, and eyes to embody and predict the robot's actions before and after they wrote their codes to make robots perform what they want to do.

## Reflecting on Mistakes

Coding and programming are the most widely acknowledged ways of teaching computational thinking (Bauer et al., 2015; Lye and Koh, 2014) and therefore Lye and Koh (2014) asked students to verbalize their thought process using think-aloud protocol while programming. The think aloud process has been proved useful in fostering computational thinking, information processing, scaffolding, and reflection activities.

Frequently what happens to students while they are doing computer work is that computers do not always execute tasks as instructed. This is also true for students learning computational thinking skills. Students are encouraged to reflect on why their plan did not work, where possible mistakes reside, and how they could best fix their mistakes in their problem-solving. Bers et al. (2014) incorporated a debugging/trouble-shooting idea in their *TangibleK* Robotics project designed to engage kindergarten children in learning computational thinking, robotics, programming, and problem-solving. Harrison and Hanebutte (2018) turned coding mistakes into a pedagogy to teach computational thinking. Instead of merely showing and explaining correct solutions, they presented code with logical errors to class. Their teaching strategy consists of three stages: Initial Instruction, Problem Posing, and Addressal. The difficulty level might be critical in this way of teaching computational thinking because they are apt to get frustrated if the task is beyond their capability or the mistakes are hard to find or fix. This strategy should not be used until the students are comfortable with basic knowledge and constructs of coding (Harrison and Hanebutte, 2018). They recommended using this technique together with other methods for better balance. In this study, reflecting on mistakes was integrated into the U<sup>2</sup>MC strategy. Thus, when the robot did not perform what the code instructed, participants came back to their code and analyzed them for mistakes, corrected it, and tried the revised code again. They repeated this trial and error process until they succeeded.

## Creating a Story and Narration

Chiazzese et al. (2017) added a narrative stage for elementary students at the beginning of the teaching process of computational thinking as suggested by Repenning et al. (2017). Based on problem-based learning, Repenning et al. (2017) developed three stages of teaching computational thinking: abstraction for problem formulation, automation for solution expression, and analysis for execution and evaluation. Considering the elementary students' age, a storyline stage with a narrative description of characters and events in a story was added to the three stages by Chiazzese et al. (2017). The adoption of a narrative approach has stimulated a positive perception of computer programming for children in the study of Chiazzese et al. (2017).

Another narration strategy was adopted by Faber, Ven, and Wierdsma (2017). Students first created a pen-and-paper model of their story, consisting of drawings indicating what happens in the story. This model acts as an abstraction of the story, highlighting the most critical aspects, which then guides the coding process. A story or narration can be introduced as a scaffold either in the beginning or middle of teaching computational thinking concepts as revealed in the study of Webb and Rosson (2013). The students in this study were asked to make changes to the story to solve problems using broadcasting in Scratch. Webb and Rosson (2013) observed that scaffolded examples with story modifications in Scratch could provide an effective way to convey computational thinking concepts and skills in a short amount of time, while still serving as a fun and engaging learning activity. This 'Creating a Story and narration' strategy was integrated into the U<sup>2</sup>MC strategy. Thus, when a new task was given to participants, they were asked to write a short story on how their robots will perform the task and what should be done in sequence.

## U<sup>2</sup>MC (Understanding/Using-Modifying-Creating)

The third strategy for teaching computational thinking includes using a prototype or sample, modifying or elaborating on it, and then creating a final project. The work of Figueiredo and García-Peñalvo (2017) illustrates this strategy. They introduced '*Practice Map Design*' and '*Follow and Give Instructions*' in order to practice and promote the computational thinking skills of students. With map designing exercises, students develop their capacities in planning, designing and describing specific characteristics in a concrete situation. Students are asked to draw on a paper what a student (or a teacher describes) and reverse roles. This strategy can also be applied without any digital devices.

Conde et al. (2017) promoted computational thinking by using unplugged methods and employing robots as teachers as an engagement factor for the students. The children played a game in class using colored game tokens where they were asked to write down the steps they took to complete a figure with colored tokens. In their study on making music with Scratch to teach computational thinking, Ruthmann et al. (2010) used a tangible computing device which is a midi card and an approach identical with the UMC/U<sup>2</sup>MC approach. Once the participants in their study understand basic note and sound generation in Scratch, they implemented synchronization, and then more musical, generative algorithms for creating and manipulating sequences of notes could be explored. In this study, participants were given a set of codes, explained what the codes do, and then watched the robot's performance. Once they understood the codes, the instructor asked where in the program students could modify

**Table 1.** Bebras Challenge Scoring Rubric

Difficulty	Correct	Incorrect	Unanswered
A	+6	-2	0
B	+9	-3	0
C	+12	-4	0

the code to change the robot's action. All the participants were given a similar task as the example program with which to write their codes.

As is evident in the literature, practices integrating computational thinking in elementary education are growing. More resources are provided, and various strategies are emerging. Strategies promoting elementary children's computational thinking are based on problem-based learning, project-based learning, and game-based learning (Hsu et al., 2018). A modified U<sup>2</sup>MC strategy in this study was integrated with strategies of Manipulating Embodied Objects, Reflecting on Mistakes, and Creating a Story and Narration.

## RESEARCH QUESTIONS

In this study, the U<sup>2</sup>MC (Understand/Use-Modify-Create) strategy (Lee et al., 2011) toward programming a robot was applied in addition to the project-based learning approach. Questions to be answered are as follows:

1. Could robotics activities with the U<sup>2</sup>MC strategy promote computational thinking skills of the participants in second grade?
2. How the participants in second grade change in their knowledge of robots after they applied the U<sup>2</sup>MC strategy in their robot activities?

## METHODS

### Participants

The study participants consist of 21 students in second grade at a suburban elementary in Boise, ID. They are 13 boys and nine girls. Academically, the students' reading and math abilities are at a second grade level range from low to high. At the commencement of the study, participants had already spent several hours with code.org during their math in classes and therefore were not unfamiliar with the languages in coding.

### Instruments

#### *Bebras Challenge for pre- and post-tests*

The idea of Bebras Challenge was born by Dagienė (2006) as an international initiative on informatics at schools. In this study, the Bebras Challenge was administered before and after the implementation. The pretest showed that participants could not finish all questions within given forty minutes. After the pretest, all items were reversed to avoid memorizing questions. This challenge examines students' logic and computational thinking skills through different types of problems. There are three levels of difficulty: A, B, and C. A-level is easier than B, which are intended to be easier than the C-level, which involves a set of problem-solving skills. The challenges contain six tasks with 45 minutes to finish, two A-levels, two B-levels, and two C-levels. The challenge question 1, "Shelf Sort", measures Algorithmic Thinking (AL), Decomposition (DE), Evaluation (EV), and Algorithms and Programming (AP) domains that students can compare the rules that Beatrix set of itself as an algorithm and data can take many structures such as pictures or numbers each with different values. Question 2, "Broken Window" measures Abstraction (AB) and EV skills, and AP domains that students can store many pieces of information to share common attributes. Question 3 "Tube System" measures AL and AP domains that students need to command the mouse to go down and keep changing the directions until arriving at the cheese. Question 4, "Bottles" measures AB and EV skills, and Data structures and Representations (DR) domains that students solve which bottles should be at the front before they disappear behind one of the other bottles. Question 5, "Car Trip" measures AL and DE skills, and AP domains that students need to command the car to arrive at school. Question 6 "Secret Recipe" measures AL and DE skills and DR domains that students need to find which ingredient has no label.

#### *U<sup>2</sup>MC activity*

In this study, students followed the U<sup>2</sup>MC strategy integrated with other three strategies. The participants' activity was guided by a teacher who had received training by the researchers. In the first step, students ran a program that controls a robot and watched the program execution and the connected robot's actions; this is a 'Use'

activity. After that, the teacher explained what the program is and what it does. Students are expected to have 'Understanding' through the teacher's explanation. After becoming familiar with the sophistication of the program, they began to modify it based on their understanding. In this 'Modify' stage, the teacher gave students brief ideas where they could make modifications, after which students had time to modify and play the program. Participants used their arms, legs, and eyes to embody and predict the robot's actions after they modified the program. This allowed participants to develop a deeper understanding and have a modified program for their robots to execute a different action from the original program. When the robot did not perform what the modified code instructed, participants came back to their code and analyzed it for mistakes, made corrections, and tried the revised code again. They repeated this trial and error process until they succeeded. In the 'Create' stage, they developed their ideas for a new robot project and deployed their knowledge and skills. That is, when a new task was given to participants, they were asked to write a short story on how their robots would perform the task and what should be done in sequence.

### **STEM Mars Robot Activities**

Twenty-two students participated in the classroom activities in STEM Mars Robot. This activity provided K-2 classroom exposure to computer programming concepts and explored Mars learning outcomes (Yang et al., 2018). There were eight lessons in total for ten days to teach Mars Robot, geared towards developing the students' CT skills, such as developing their ability to make algorithms, and to write and debug code.

In the breakout lesson, Lesson 1: Mars and Robots, students learned and shared ideas about Mars and Robotics. During this lesson, students had discussions about why humans would want to go to Mars or, alternatively, send a robot to Mars. This discussion provided a foundation for Lesson 2: Watching a video on robots used in our daily life; wherein students discussed what comprises a robot and how robots and robotics can be leveraged on Mars to potentially discover life and water. Lesson 3: Building a Robot brought the pre-learning from the previous lessons into the students' hands, and provided them with the opportunity to build their own EV3 Lego robot. During this lesson, groups of five students followed the robot building directions with teacher guidance as appropriate. To account for students who were at different centers, an alternative activity was leveraged in this lesson, in which these students participated in creating a robot prototype using Legos or read an informational text about Mars. After successfully building a robot prototype, students learned how to control a robot in Lesson 4: Controlling the Robot. This included basic movements and leveraging sensors to detect objects potentially obstructing the path of the robot by using the U<sup>2</sup>MC approach to controlling a robot.

After Lesson 4, students used the UMC approach toward coding throughout the lessons. In Lesson 5: Algorithm, Coding, and Debugging, teachers showed the Cup Stack Pack to students and students created algorithms and coding to match the Cup Stack Pack. Students debugged code when necessary with guidance and support provided throughout the lesson, while still ensuring enough time for students to explore the basics of coding using the cups. In Lesson 6 & 7: My Loopy Robotics Friends, students chose a program from My Robotic Friends. This lesson served as a reintroduction to loops. Students developed critical thinking skills by looking for patterns of repetition in the movements of classmates and determining how to simplify those repeated patterns using loops. They identified places where the same arrow repeats consecutively and they wrote the number of repeated arrows inside the circle, while crossing out the other arrows in the repeated arrows. Similar to Lesson 5, teachers provided guidance and support, while still giving sufficient time for students to explore and practice. Finally, in Lesson 8: Working Mars Robots, students wrote how they used the computational model to problem solve during the lessons, such as building the robots, designing a robot, completing My Robotic Friends, and My Loopy Robotic Friends or discussing the activities of the Working Mars Robots.

### **Interview**

To find out how students were learning about robotics and its programming, an interview was performed with questions such as 'What did you learn today?', 'What was new to you?', 'Was it difficult?', and other immediate facilitating questions such as 'Could you tell me more in detail?', etc. The interview was conducted four times by trained graduate students majoring in education and counseling: at the beginning of the implementation, after the students assembled their robots, after Lesson 3, and after all robotics activities. For the interview, two students from each group were selected at random, resulting in a total of eight students that were interviewed individually. The first interview, which was not included in the qualitative analysis, focused on robots in general, their parts and their role. It was an orientation towards the coming interviews. The second interview was conducted after lesson 5 and focused on coding. The third interview was conducted after all activities and focused on coding. The interview was conducted in a very comfortable, informal manner and students were asked to share what they learned. After students responded to the questions, the interviewer probed further to get additional information or clarification.



**Table 2.** Scores of pre and post-test of Bebras Challenge

Students	Pre-test	Post-test	Increase
1	2	18	16
2	-8	10	18
3	-6	-5	1
4	2	18	16
5	10	10	0
6	6	14	8
7	-10	2	12
8	2	10	8
9	-7	10	17
10	10	10	0
11	2	-2	-4
12	-9	0	9
13	6	10	4
14	10	10	0
15	-10	-10	0
16	-10	2	12
17	14	26	12
18	22	38	16
19	-10	-2	8
20	8	14	6
21	-10	2	12
Sum	16	175	159
Mean	.761	8.333	8.143

**Table 3.** Paired samples t-test of pre- and post-tests

Test	Mean Difference	Std. Deviation	t	df	Sig.
Post – Pre	8.143	6.733	5.542	20	.000

**Table 4.** Pre and post test scores by CT items

Item # (Type & sequence)	CT skill & domain	Sum of pre-test	Sum of post-test	Increase
A1	AL, DE, EV and AP	17	52	35
A2	AB, EV and AP	29	74	45
B3	AL and AP	-7	24	31
B4	AB, EV and DE	-5	36	41
C5	AL, EV, DR and AP	-10	-11	-1
C6	AL, DE and AP	-8	0	8
Sum		16	175	159

## RESULTS AND DISCUSSION

Quantitative Analysis: Because one student missed the pre-test, twenty-one students' data obtained from the Bebras Challenge was analyzed. The pre- and post-test scores of the Bebras Challenge are presented in [Table 2](#).

Sixteen students out of twenty-one showed increased scores from the pre-test to the post-test. Only five students showed the same or decreased in scores. The mean of the pre-test is .761 while that of the post-test is 8.333. The mean of the Increase is 8.143.

The paired samples test procedure in SPSS is presented in [Table 3](#). The difference between the pre- and post-test is significant ( $t=5.542$ ,  $df=20$ ,  $p < .01$ ) ([Table 3](#)). The most notable differences were in question type A and B. Type C did not show as much difference as type A and B ([Table 4](#)). According to [Table 4](#), the sum of the difference is more than 35 in type A and B.

Type C, which has a higher difficulty level, did not show much difference between pre- and post-tests. This smaller or less significant difference may be due to the difficulty level and DR (Data Structures and Representations) trait in question C5.

Qualitative Analysis: The first interview performed before the implementation was not included in the qualitative analysis because it was focused on robots in general. The other three interviews were focused on identifying any changes in student knowledge and attitudes. The second, third and fourth interviews conducted during the implementation were recorded on video. The dialogues in the videos were transcribed and the researchers extracted any meaningful dialogues from the transcriptions. The findings are summarized below.

1) A robot is a machine, has a chip, and accepts orders to move

Findings show that the participants were narrowing down their understanding about a robot from 'it is a machine' to 'it needs to be programmed using codes' when they were asked 'What do you think a robot is?'. Two students did not answer or were not sure about this question, and six students' answers stated that 'it is a machine' at first interview, but later five students answered stated that 'it is a machine' or 'has the microchip', etc. They understood a robot reacts to commands or instructions'. Below, a few dialogues related to this observation at the second and third interviews are presented.

*Student A:* Well that a robot, it is a machine...what if it doesn't need an engine to move 'cause sometimes you could just have it in the microchip to tell it how to move?

*Student B:* What if a robot had no brain, no microchip, no programing?

*Student C:* Well that a robot, it is a machine...what if it doesn't need an engine to move 'cause sometimes you could just have it in the microchip to tell it how to move?

*Student D:* Chips.

2) No brain! It should be programmed

*Student A:* You have to tell the robot what to do—

*Student B:* - using the robot language instead of human language.

*Student C:* Well, I didn't know that we can make some robots and we can move or control them. That was kind of cool.

*Interviewer:* Yeah, it's neat. You can program them to do whatever you want them to do, pretty much, huh?

*Student D:* Yes. That how come we need to program a robot, but it can't move by itself. Then I watched a video, and it's because that it doesn't have a brain like we do. It doesn't have a heart. Yeah.

*Student E:* I can send my order to my robot one by one or send all at once. It follows my words.

The above dialogues show that the participants think a robot is a machine with no brain, they have chips instead to hold programmed instructions. They did not mention the codes, but later they learned to code to give controls to robots.

3) A robot acts only when commands are given from outside.

At the beginning of the implementation, eight of the students who were interviewed knew that a robot is an automatic machine that works autonomously. However, they did not know it should be instructed or programmed to do something. However, when they were programming a robot, they all could easily understand that a robot does nothing unless instructed, and only does precisely what the program directs. Dialogues with one student are presented below, as a representative of all the other seven students' dialogues.

*Interviewer:* How do you make a robot move?

*Students G:* I say and select, "move forward!". Then robot moves forward.

*Interviewer:* What happens if you do not say or select any command? It moves?

*Students G:* No, it is not moving, it is frozen, waiting for my command.

*Interviewer:* So, do you think when you have delivered a wrong command? The robot can judge if it is wrong?

*Students G:* No, the robot just accepts the command and just do it.

4) We repeat 'Trial and Error'

When they were writing the code to make a robot move or turn, they wrote a series of codes which consisted of breaking down the steps needed to achieve a given goal. After they typed the codes in on the computer, the students transferred all of codes into the chipset of the robot. Students then placed the robot on the floor and tested to see if it was executing the code as expected. If the robot was not executing the commands as instructed, students would then have to use problem solving skills to isolate where mistakes were made, and how it could be fixed. After identifying the mistakes, students would return to their computers and correct the codes and then test it again. This was a cyclical process until success was achieved.

*Interviewer:* What if something goes wrong? What do you do?

*Interviewee:* We solve it again.

..

*Interviewer:* Okay, how do you solve if your robot is not working as you think?

*Interviewee:* A mistake and then we fix it again, or something like that.

..

- Interviewee:* Okay. I would try and make as much mistakes ever to—so I write down the mistakes I make and so I have a perfect robot.
- ..
- Interviewer:* In what ways? Yeah, that's what I'm asking.
- Interviewee:* Maybe, if there's a piece. If it doesn't go in that side, maybe you should try another side and put it in there.
- Interviewer:* Yeah. You find a problem, then you research it and find different ways to solve it. Yeah. Rita? Do you want to say something about the chart?
- Interviewee:* If we make a problem, then we can break it.
- Interviewee:* Break it?
- Interviewee:* If we're trying to make a robot and we make—go in, we can take it apart, and we'll know, and then we can research it, then fix it.

## CONCLUSIONS

In this study, the U<sup>2</sup>MC (Understand/Use-Modify-Create) strategy toward programming a robot was applied in addition to the project-based learning approach model. It was anticipated that U<sup>2</sup>MC strategy could be relevant for students in second grade because it makes sure they understand computational steps entirely before using, modifying and creating their own programs. The participants in second grade performed robotics programming successfully using the U<sup>2</sup>MC strategy. The 'Understand' activity before 'Use' is assumed to be effective in engaging participants and making the activity effective towards the end-goal of robotics programming.

The participants in this study showed increased knowledge about robots and computational thinking skills after the STEM+C robotics activities. Throughout the interviews, they began to understand that a robot is a machine, has a chip, and accepts orders to move; that it has no brain like a human being and should be programmed using commands given from outside; and that 'Trial and Error' happens when they program robots.

At the easy and intermediate challenge levels for computational thinking, students' increase in computational thinking skills proved to be greater than at the most difficult level of challenge. However, it is uncertain whether the immeasurable changes in student computational thinking at higher levels of difficulty could be a result of the domain of computational thinking, that is, Data Structure and Representation. To simplify, the participants might not be ready for this domain of computational thinking, or it may be due to the lesson not being modified to adequately teach the domains to second graders. In Chen et al.'s (2017) study, the students in fifth grade did not show significant gains on Data and Representation of computational thinking domains either.

The results of this study indicate that further study is needed to clarify the readiness of second graders toward this domain of computational thinking. Additionally, this study found that the STEM+C robotics activities have given the participants in second grade opportunities to understand the basic principles of robotics: operation, composites, and codes. Students demonstrated the understanding that a robot is a machine composed of several parts consisting of chips similar to a human brain. The chipset in each robot can accept instructions written in codes to execute tasks, and that erroneous codes can be corrected through systematic testing and debugging.

Further studies should be done to determine which domains of computational thinking can be mastered by students in second grade, exploring which coding concepts are more appropriate for this age bracket. Finally, difficulty levels in computational thinking skills and coding concepts should also be clarified further in subsequent studies.

## ACKNOWLEDGEMENT

We wish to thank the National Science Foundation (NSF) for the support of this study under Grant Number 1640228. Any opinions, findings, and conclusions or recommendations expressed in this material are those of the authors and do not necessarily reflect the views of the NSF.

## REFERENCES

- Aho, A. V. (2012). Computation and computational thinking. *The Computer Journal*, 55(7). 832-835.  
<https://doi.org/10.1093/comjnl/bxs074>
- Baratè, A., Ludovico, L. A. and Malchiodi, D. (2017). Fostering computational thinking in primary school through a LEGO-based music notation. *Procedia Computer Science*, 112(2017), 1334–1344.  
<https://doi.org/10.1016/j.procs.2017.08.018>

- Barr, V. and Stephenson, C. (2011). What is involved and what is the role of the computer science education community? *ACM Inroads*, 2(1), 48-54. <https://doi.org/10.1145/1929887.1929905>
- Bauer, A., Butler, E. and Popovic, Z. (2015). Approaches for teaching computational thinking strategies in an educational game: A position paper. In *Proceedings of the IEEE Blocks and Beyond Workshop* (121 - 123). <https://doi.org/10.1109/BLOCKS.2015.7369019>
- Bers, M. U., Flannery, L., Kazakoff, E. R. and Sullivan, A. (2014). Computational thinking and tinkering: Exploration of an early childhood robotics curriculum. *Computers & Education*, 72(2014), 145-157. <https://doi.org/10.1016/j.compedu.2013.10.020>
- Chen, G., Shen, J., Barth-Cohen, L., Jiang, S., Huang, X. and Eltoukhy, M. (2017) Assessing elementary students' computational thinking in everyday reasoning and robotics programming. *Computers and Education*, 109(C), 162-175. <https://doi.org/10.1016/j.compedu.2017.03.001>
- Chiazzese, G., Fulantelli, G., Pipitone, V. and Taibi, D. (2017). Promoting computational thinking and creativeness in primary school children. In J. M. Dodero, M. S. Ibarra Sáiz, & I. Ruiz Rube (Eds.), *Fifth International Conference on Technological Ecosystems for Enhancing Multiculturality (TEEM'17)*, October 18-20, 2017, Cádiz, Spain. (Article 6). New York, NY, USA: ACM. <https://doi.org/10.1145/3144826.3145354>
- Ching, Y.-H., Yang, D., Wang, S., Baek, Y., Swanson, S. and Chittoori, B. (2018). Improving student attitudes in STEM through a project-based robotics program. *A paper presented at American Educational Research Association (AERA) Annual Meeting and Exhibition*, New York, NY, USA, April 13-17, 2018.
- Committee for the Workshops on Computational Thinking; National Research Council (2010). *Report of a workshop on the scope and nature of computational thinking*, The National Academies Press. Washington, D.C.
- Conde, M. Á., Fernandez-Llamas, C., Rodríguez-Sedano, F. J., Guerrero-Higueras, Á. M., Matellan-Olivera, V. And García-Peñalvo, F. J. (2017). Promoting computational thinking in K-12 students by applying unplugged methods and robotics. In J. M. Dodero, M. S. Ibarra Sáiz, & I. Ruiz Rube (Eds.), *Fifth International Conference on Technological Ecosystems for Enhancing Multiculturality (TEEM'17)*, October 18-20, 2017, Cádiz, Spain. (Article 6). New York, NY, USA: ACM. <https://doi.org/10.1145/3144826.3145354>
- Dagiené, V. (2006). Information technology contests - introduction to computer science in an attractive way. *Informatics in Education*, 5(1), 37 - 46.
- Dasgupta, A., Rynearson, A. M., Purzer, S., Ehsan, H. and Cardella, M. E. (2017). Computational thinking in K-2 Classrooms: Evidence from student artifacts (Fundamental). *A paper presented at American Society for Engineering Education Annual Conference and Exhibition*, June 25-28, 2017, Columbus, Ohio. <https://doi.org/10.18260/1-2--28062>
- Elkin, M., Sullivan, A. and Bers, M. U. (2014). Implementing a robotics curriculum in an early childhood Montessori classroom. *Journal of Information Technology Education: Innovations in Practice*, 13, 153-169. <https://doi.org/10.28945/2094>
- ET 2020 Working Group on Digital Skills and Competences (2016). *Coding and computational thinking on the curriculum, Key messages of PLA#2*. Retrieved from [https://ec.europa.eu/education/sites/education/files/2016-pla-coding-computational-thinking\\_en.pdf](https://ec.europa.eu/education/sites/education/files/2016-pla-coding-computational-thinking_en.pdf)
- Faber, H. H., Ven, J. S. and Wierdsma, M. D. (2017). Teaching computational thinking to 8-year-olds through ScratchJr. *ITiCSE '17 Proceedings of the 2017 ACM Conference on Innovation and Technology in Computer Science Education* (pp. 359-359). July 03-05, 2017, Bologna, Italy. <https://doi.org/10.1145/3059009.3072986>
- Fathi, R. and Hildreth, D. (2017). Computational thinking and application – a cross curricular approach to teach computer science in high school chemistry classrooms. *2017 Proceedings of the EDSIG Conference*, v3 n4357, Austin, Texas USA
- Figueiredo, J. and García-Peñalvo, F. J. (2017). Improving computational thinking using follow and give instructions. In J. M. Dodero, M. S. Ibarra Sáiz, & I. Ruiz Rube (Eds.), *Fifth International Conference on Technological Ecosystems for Enhancing Multiculturality (TEEM'17)*, October 18-20, 2017, Cádiz, Spain. (Article 3). New York, NY, USA: ACM. <https://doi.org/10.1145/3144826.3145351>
- Good, J., Romero, P., du Boulay, B., Reid, H., Howland, K. and Robertson, J. (2008). An embodied interface for teaching computational thinking, *Proceedings of the 13th international conference on Intelligent user interfaces* (pp. 333-336), January 13-16, 2008, Gran Canaria, Spain. <https://doi.org/10.1145/1378773.1378823>
- Gouws, L., Bradshaw, K. and Wentworth, P. (2013). Computational thinking in educational activities: An evaluation of the educational game Light-Bot. *ITiCSE'13*, July 1-3, 2013, Canterbury, England, UK. <https://doi.org/10.1145/2462476.2466518>
- Grover, S. and Pea, R. (2013). Computational thinking in K-12: A review of the state of the field. *Educational Researcher*, 42(1). 38-43. <https://doi.org/10.3102/0013189X12463051>
- Harrison, W. S. and Hanebutte, N. (2018). Embracing coding mistakes to teach computational thinking. *Journal of Computing Sciences in Colleges*, 33(6). 52-62.

- Hemendinger, D. (2010). A please for modesty. *ACM Inroads*, 1(2), 4–7. <https://doi.org/10.1145/1805724.1805725>
- Hsu, T. C., Chang, S. C. and Hung, Y. T. (2018). How to learn and how to teach computational thinking: Suggestions based on a review of the literature. *Computers & Education*, 126(2018), 296-310. <https://doi.org/10.1016/j.compedu.2018.07.004>
- International Society for Technology in Education (ISTE) and the Computer Science Teachers Association (CSTA) (2011). *Computational thinking teacher resources*, second edition. Retrieved from <https://www.csteachers.org/>
- Johnson, D., Black, B., McGriff, M. and Daney, K. (2014). Using technology to promote computational thinking in middle school classrooms. In M. Searson & M. Ochoa (Eds.), *Proceedings of Society for Information Technology & Teacher Education International Conference 2014* (pp. 2866-2868). Chesapeake, VA: Association for the Advancement of Computing in Education (AACE).
- Jörg, S., Leonard, A. E., Badu, S., Gundersen, K., Parmar, D., Boggs, K. and Daily, S. B. (2014). Character animation and embodiment in teaching computational thinking. *SIGGRAPH '14 ACM Posters Article No. 4*, August 10 – 14, 2014, Vancouver, British Columbia, Canada. <https://doi.org/10.1145/2614217.2630597>
- Kazakoff, E., Sullivan, A. and Bers, M. U. (2013). The effect of a classroom-based intensive robotics and programming workshop on sequencing ability in early childhood. *Early Childhood Education Journal*, 41(4), 245–255. <https://doi.org/10.1007/s10643-012-0554-5>
- Kazimoglu, C., Kiernan, M., Bacon, L. and MacKinnon, L. (2012). Learning programming at the computational thinking level via digital game-play. *Procedia Computer Science*, 9, 522-531. <https://doi.org/10.1016/j.procs.2012.04.056>
- Lee, I., Martin, F., Denner, J., Coulter, B., Allan, W., Erickson, J., Malyn-Smith, J. and Werner, L. (2011). Computational thinking for youth in practice. *ACM Inroads*, 2(1), 32-37. <https://doi.org/10.1145/1929887.1929902>
- Li, W. L., Hu, C. F. and Wu, C. C. (2016). Teaching high school students computational thinking with hands-on activities. *ITiCSE 2016: Proceedings of the ACM Conference on Innovation and Technology in Computer Science Education* (pp. 371-371). July 11-13, 2016. Arequipa, Peru. <https://doi.org/10.1145/2899415.2925496>
- Lieto, M. C. D., Inguaggiato, E., Castro, E., Cecchi, F., Cioni, G., Dell’Omo, M., Laschi, C., Pecini, C., Santerini, G., Sgandurra, G. and Dario, P. (2017). Educational robotics intervention on executive functions in preschool children: A pilot study. *Computers in Human Behavior*, 71(2017), 16-23. <https://doi.org/10.1016/j.chb.2017.01.018>
- Liu, H. P., Perera, S. M. and Klein, J. W. (2017). Using model-based learning to promote computational thinking education. In P. J. Rich and C. B. Hodges (Eds.) *Emerging research, practice, and policy on computational thinking* (pp. 153-172). Cham, Switzerland: Springer International Publishing AG. [https://doi.org/10.1007/978-3-319-52691-1\\_10](https://doi.org/10.1007/978-3-319-52691-1_10)
- Lye, S. Y. and Koh, J. H. L. (2014). Review on teaching and learning of computational thinking through programming: What is next for k-12? *Computers in Human Behavior*, 41(C), 51–61. <https://doi.org/10.1016/j.chb.2014.09.012>
- Repenning, A., Basawapatna, A. R. and Escherle, N. A. (2017). Principles of computational thinking tools. In P. J. Rich & C. B. Hodges (Eds.) *Emerging research, practice, and policy on computational thinking* (pp. 291-305). Cham, Switzerland: Springer International Publishing AG. [https://doi.org/10.1007/978-3-319-52691-1\\_18](https://doi.org/10.1007/978-3-319-52691-1_18)
- Ruggieri, S. (2000). Decidability of logic program semantics and applications to testing. *The Journal of Logic Programming*, 46(1-2), 103-137. [https://doi.org/10.1016/S0743-1066\(99\)00067-9](https://doi.org/10.1016/S0743-1066(99)00067-9)
- Ruthmann, A., Heines, J. M., Greher, G. R., Laidler, P. and Saulters, C. (2010). Teaching computational thinking through musical live coding in Scratch, *SIGCSE'10 - Proceedings of the 41st ACM Technical Symposium on Computer Science Education* (pp. 351-355). 41st ACM Technical Symposium on Computer Science Education, Mar 10-13, 2010. Milwaukee, WI, United States. <https://doi.org/10.1145/1734263.1734384>
- Shoop, R., Flot, J., Friez, T., Schunn, C. and Witherspoon, E. (2016). Can computational thinking practices be taught in robotics classrooms? *Presented at the International Technology and Engineering Education Conference*, National Harbor, Washington DC. March 2-4, 2016.
- Sullivan, F. R. and Heffernan, J. (2016) Robotic construction kits as computational manipulatives for learning in the STEM disciplines. *Journal of Research on Technology in Education*, 48(2), 105-128, <https://doi.org/10.1080/15391523.2016.1146563>
- The Computer Science Teachers Association (CSTA, 2011). *CSTA K-12 Computer science standards, Revised edition*. CSTA, New York.
- The Royal Society (2012). *Shut down or restart? The way forward for computing in UK schools*. London: The Royal Society. Retrieved from <https://royalsociety.org/~media/education/computing-in-schools/2012-01-12-computing-in-schools.pdf>



- Tran, Y. (2018). Computational thinking equity in elementary classrooms: What third-grade students know and can do. *Journal of Educational Computing Research*, January, 2018. <https://doi.org/10.1177/0735633117743918>
- Tsarava, K., Moeller, K. and Ninaus, M. (2018). Training computational thinking through board games: The case of Crabs & Turtles. *International Journal of Serious Games*, 5(2), 25-44. <https://doi.org/10.17083/ijsg.v5i2.248>
- Voogt, J., Fisser, P., Good, J., Mishra, P. and Yadav, A. (2015). Computational thinking in compulsory education: Towards an agenda for research and practice. *Education and Information Technologies*, 20(4). 715–728. <https://doi.org/10.1007/s10639-015-9412-6>
- Webb, H. C. and Rosson, M. B. (2013). Using scaffolded examples to teach computational thinking concepts. *SIGCSE '13 Proceeding of the 44th ACM technical symposium on Computer science education*, (pp. 95-100). March 06-09, 2013. Denver, Colorado, USA. <https://doi.org/10.1145/2445196.2445227>
- Weintrop, D., Beheshti, E., Horn, M., Orton, K., Jona, K., Trouille, L. and Wilensky, U. (2016). Defining computational thinking for mathematics and science classrooms. *Journal of Science Education and Technology*, 25(1), 127-147. <https://doi.org/10.1007/s10956-015-9581-5>
- Wing, J. (2006). Computational thinking. *Communications of the ACM*, 49(3), 33–36. <https://doi.org/10.1145/1118178.1118215>
- Wing, J. (2008). Computational thinking and thinking about computing. *Philosophical Transactions. Series A, Mathematical, Physical, and Engineering Sciences*, 366(1881), 3717–3725. <http://doi.org/10.1098/rsta.2008.0118>
- Yadav, A., Mayfield, C., Zhou, N., Hambruch, S. and Korb, J. T. (2014). Computational thinking in elementary and secondary teacher education. *ACM Transactions on Computing Education*, 14(1), Article 5, 1-16. <https://doi.org/10.1145/2576872>
- Yang, D., Baek, Y., Ching, Y., Swanson, S., Chittoori, B. and Wang, S. (2018). The design and enactment of a computational thinking-rich project-based integrated K-12 STEM curriculum. *Manuscript submitted for publication*.



## Revisiting Race and Gender Differences in STEM: Can Inclusive STEM High Schools Reduce Gaps?

Melanie LaForce <sup>1</sup>, Huifang Zuo <sup>1\*</sup>, Kaitlyn Ferris <sup>1</sup>, Elizabeth Noble <sup>2</sup>

<sup>1</sup> *The University of Chicago*, USA

<sup>2</sup> *Mission Measurement*, USA

\*Corresponding Author: [hzu@uchicago.edu](mailto:hzu@uchicago.edu)

**Citation:** LaForce, M., Zuo, H., Ferris, K. and Noble, E. (2019). Revisiting Race and Gender Differences in STEM: Can Inclusive STEM High Schools Reduce Gaps? *European Journal of STEM Education*, 4(1), 08. <https://doi.org/10.20897/ejsteme/5840>

**Published:** July 18, 2019

### ABSTRACT

**Background:** Over the past two decades, inclusive STEM (science, technology, engineering, and mathematics) high schools have emerged as one strategy for increasing and broadening participation in STEM majors and careers, particularly for currently underrepresented students in those fields. However, limited research has examined whether strategies used in inclusive STEM schools can actually improve students' STEM-related attitudes and academic achievement, and reduce gender and race/ethnicity gaps.

**Material and Methods:** The current exploratory study uses multiple linear regression models to examine associations between students' ratings of inclusive STEM school strategies and student outcomes. Interactions were also used to explore whether such associations differed by students' gender identity and race/ethnicity.

**Results:** Results indicate that when students report positive implementation of specific strategies used by inclusive STEM schools, race/ethnicity and gender gaps in science attitudes and overall academic achievement are reduced or reversed.

**Conclusions:** Findings from this study set the stage for further research, suggesting that while some inclusive STEM high school strategies may have the potential to contribute to STEM outcomes across diverse populations of students, significant gaps remain.

**Keywords:** STEM education, science education, gender and race/ethnicity gaps, inclusive STEM school

### INTRODUCTION

Despite the diversity of the U.S. population overall, our nation continues to see high rates of gender and racial/ethnic inequality in science, technology, engineering, and mathematics (STEM) fields, with the composition of STEM college majors and the STEM workforce more broadly dominated by White males (e.g., National Science Board, 2016; National Science Foundation, 2017). For example, Hispanics/Latino and Black students, who represent a combined 26% of the U.S. population (21 or older), account for only 15% of STEM college degree holders and 11% of the STEM workforce (National Science Board, 2016). Similarly, women represent only 29% of total workers in STEM fields, although this number varies greatly across fields (with women well-represented in social and biological/life sciences occupations) (National Science Board, 2016). These inequalities, if not

addressed, pose critical problems for the country in that a continuing lack of ethnic and gender diversity in these high-income STEM fields has the potential to exacerbate existing financial and cultural stratifications of traditionally disadvantaged groups (Weis, Eisenhart, Cipollone, Stich, Nikischer, Hanson, Leibbrandt, Allenm, and Dominguez, 2015).

In response, educators and policymakers alike are working to increase and broaden participation in STEM education (National Research Council, 2011). Over the past several years, inclusive STEM schools have emerged as one strategy for broadening the pipeline to STEM careers with providing high-quality and engaging STEM education for all students, but particularly for currently underrepresented students in those fields (Peters-Burton, Lynch, Behrend, and Means, 2014). As such, the goals of inclusive STEM schools include increasing students' STEM achievement *and* their attitudes toward and interest in STEM. While some studies have begun to examine inclusive STEM school student outcomes (e.g., Gnagey and Lavertu, 2016; Means, Wang, Wei, Lynch, Peters, Young, and Allen, 2017), there is currently only limited evidence of the specific mechanisms by which these schools may be working to promote student outcomes and to reduce academic achievement and interest gaps between different groups of students. The current study contributes to the existing literature on this topic by examining whether strategies used in inclusive STEM schools predict science attitude and achievement outcomes, and whether outcomes differ by student gender identity or race/ethnicity. By doing so, we begin to gain a clearer picture of not only *if*, but *how* STEM schools may be reducing long-standing gaps in STEM education, in turn potentially contributing to greater equality in the workforce and society over time.

### **STEM Participation – Inequities and the Importance of Attitudes and Interest**

Despite overall improvements in standardized test score performance over the past 25 years, Black and Hispanic/Latino students continue to have lower levels of general academic achievement compared to White students (National Center for Education Statistics, 2013). Gaps are large in STEM disciplines, with recent National Assessment of Educational Progress (NAEP) data showing substantial differences between White and both Black and Hispanic/Latino students in science (NAEP, 2015a, 2015b). Gender differences also exist, with only 19% of female students scoring at or above proficient, compared to 25% of males. Recent Trends in International Mathematics and Science Study (TIMSS) data indicate that the gender gap has steadily narrowed over the past 20 years; however, for example, 8<sup>th</sup> grade boys continue to have significantly higher science achievement scores than girls (Martin, Mullis, Foy, and Hooper, 2016). While achievement scores represent only one measure of success, these numbers are important, as 'test score disparities in elementary and secondary school are highly predictive of corresponding disparities in subsequent labor market outcomes' (Reardon, Robinson, and Weathers, 2014: 18).

Moreover, female and racial/ethnic minority students who are high-achieving in STEM courses during high school are still less likely to pursue STEM majors in college compared to males and White students, regardless of previous achievement level (U.S. Congress Joint Economic Committee, 2012). This finding suggests that something other than achievement may influence students to stay in-or drop out of STEM fields. Indeed, evidence has shown that students' attitudes and interests play a role. As such, we focus specifically on students' intrinsic motivation for science, science ability beliefs, and interest in future STEM careers.

We define intrinsic motivation similar to Ryan and Deci (2000): finding something inherently interesting or enjoyable. Intrinsic motivation is activity-specific, meaning that one might be intrinsically motivated to do one thing, but not another. Additionally, it has been found to result in high-quality learning, but may be impacted positively, or negatively, by parent and/or teacher practices (Ryan and Deci, 2000). Ability beliefs, which include concepts such as confidence, self-efficacy, and self-concept, 'are defined as the individual's perception of his or her current competence at a given activity' (Wigfield and Eccles, 2000: 70). Beliefs about abilities play a large part in various motivation theories, including the expectancy-value theory (an individual's expectations for outcomes and how they value outcomes motivates their behaviors and performance when seeking such outcomes; Wigfield and Eccles, 2000); social cognitive theory (learning occurs across diverse social contexts and interpersonal dynamics; Bandura, 1997); attribution theory (the way that individuals view and interpret events contributes to their behaviors and thought processes; Weiner, 1985); and self-determination theory (individuals' intrinsic motivation aside from external influence; Ryan and Deci, 2000)." Unsurprisingly, one's abilities are measured in different ways, depending on the researchers' interest in particular aspects of perceived ability (Wigfield and Eccles, 2000). In this study, we focus on student's confidence in their abilities in science classes. Generally, beliefs about ability have been found to be positively related to meaningful cognitive engagement in tasks and involvement in academic work as well as effort, persistence, and academic achievement (Greene and Miller, 1996). In the literature, *interest* may refer to situational interest, a more temporary state induced by particular features of an environment or activity, or to individual interest, 'a relatively stable evaluative orientation towards certain domains' (Eccles and Wigfield, 2002:114). In the current study we focus on the latter, with the domain being future STEM education and career paths. While intrinsic motivation causes a person to act, interest influences the direction in which he will do so (Fortus, 2014).

High school students' interest in science has been found to be more strongly related to pursuing a STEM major than STEM course enrollment or academic achievement (Maltese and Tai, 2009). Previous research also suggests that students who have greater confidence in their abilities in STEM, higher levels of motivation, and more positive attitudes towards STEM are more likely to be interested in and to pursue STEM-related coursework and careers (Mau, 2003; Pajares, 2005; Stevens, Olivarez, Lan, and Tallent-Runnels, 2004; Wang, 2013). These findings underscore the influential role that these attitudes can have on students' pursuit of and persistence in STEM majors and/or careers. Thus, shaping positive attitudes and interests related to STEM subjects may be especially critical when it comes to closing gender and race/ethnicity gaps in STEM participation.

Gender and race gaps in such attitudes are less clear-cut than those observed in academic achievement. For instance, Black students have been found to have lower beliefs in their science abilities compared to White students (Britner and Pajares, 2001), and similarly, females are generally less confident in their science abilities than males (Wigfield and Eccles, 2002). Others, however, have found that Black and Hispanic/Latino students were as likely as White students to report an intention to declare a STEM major (Anderson and Kim, 2006; Hurtado, Eagan, and Chang, 2010). Moreover, studies exploring STEM attitudes have found complex relationships and confounding effects of gender and race. For example, the results of one study indicated that Black males were as likely as White males to report high levels of science self-concept, as well as interest in a science career. White females, Black females, and Hispanic/Latino students of both genders, however, were found to report significantly lower scores than their White male counterparts on both measures (Riegle-Crumb, Moore, and Ramos-Wada, 2011). In a second study, Black female students reported more positive attitudes towards science than White females (Hanson, 2006), whereas other research suggests that Black and Hispanic/Latino females were doubly disadvantaged given that their science achievement test scores as well as their attitudes toward the subject fell far below White males' scores (Riegle-Crumb, Moore, and Ramos-Wada, 2011). Adding to this, Else-Quest and colleagues (2013) found that males reported a higher self-concept in math than females; however, females rated science as having higher value than males. Taken together, these findings paint a nuanced, yet unclear picture of the relationships between students' gender and racial/ethnic identities and their STEM-related attitudes.

More research investigating diverse populations of students' STEM attitudes, interest, and academic achievement, as well as strategies that may promote equality across these groups, is needed. To that end, the current study examined students enrolled in inclusive STEM high schools and associations between specific strategies employed in STEM schools and students' beliefs in their science abilities, intrinsic motivation for science, and interest in future STEM careers, as well as their academic achievement. Importantly, this study also investigated whether such associations differed for males and females, and for students of different races/ethnicities.

### History and Goals of Inclusive STEM Schools

Highly competitive mathematics- and science-focused high schools, which admit students based on academic achievement, have been part of the American education system for many years (Subotnik, Tai, and Almarode, 2011). However, the federal government has more recently increased efforts to improve access to high-quality K-12 STEM education for all students with different backgrounds, regardless of prior academic achievement (White House Office of Science and Technology Policy, 2015). As such, inclusive STEM schools with open-admissions processes have emerged as one alternative to schools with the more traditionally-rigorous academic enrollment requirements (Peters-Burton et al., 2014). These schools allow for greater numbers of students—particularly students from diverse racial, ethnic, and socioeconomic backgrounds—to engage with STEM curricula.

Previous research suggests that inclusive STEM schools have goals for students that differ from many comprehensive, or traditional, high schools (LaForce et al., 2016). These goals include growing student interest and improving academic achievement in STEM-related disciplines, bolstering students' confidence in their abilities to perform in STEM fields, and increasing the number and diversity of students who pursue STEM majors and/or careers (Unfried, Faber, and Wiebe, 2014). Additionally, inclusive STEM schools put more focus on 21<sup>st</sup> century skills such as problem-solving, critical thinking, technology use, and teamwork (LaForce et al., 2016), that are also critical for success in the workplace (Burrus, Jackson, Xi, and Steinberg, 2013). This type of STEM skill-development, along with disciplinary content, is important not only for employment, but also for enabling citizens to make informed and reasoned social and political decisions, as well as personal choices about health, the environment, and other consequential issues (Committee on STEM Education National Science and Technology Council, 2013).

However, there is limited empirical evidence regarding the efficacy and effectiveness of inclusive STEM schools. Moreover, the results of research that has examined the impact of STEM school attendance on students' achievement outcomes has been mixed (Bicer, Navruz, Capraro, Capraro, Oner, and Boedeker, 2015; Hansen, 2013; Means, Wang, Young, Peters, and Lynch, 2016). For example, research focusing exclusively on STEM schools in Ohio indicated positive effects in science achievement at some of the schools, but found negative effects on academic achievement across subjects (including science) at others (Gnagey and Lavertu, 2016). Means, Wang,

Young, Peters and Lynch (2016) found that STEM school attendance had a positive effect on grade point average (GPA), though not on ACT scores, whereas Hansen (2013) found no relationship between STEM school participation and science or mathematics outcomes. One reason for these varied findings may be that, by design, large-scale policy research studies examine inclusive STEM schools as a whole—that is, as one uniform entity—without examining what is happening within the schools themselves that might contribute to effects seen or differences that are observed. Inclusive STEM schools are complex innovations that employ many types of strategies to promote student success (LaForce et al., 2016), and this ‘black box’ approach leaves researchers unable to target specific improvements or explain variation in findings. In order to fully understand whether inclusive STEM schools may indeed be an effective means to reduce inequalities in student STEM outcomes—from short-term ones such as attitudes towards STEM to longer-term outcomes such as participation in STEM majors and/or careers—it is important to consider the specific teaching and learning experiences enacted in these schools.

## What STEM Schools Do

Researchers have begun to articulate the common strategies of inclusive STEM schools by looking at existing literature and resources (e.g., Peters-Burton, Lynch, Behrend, and Means, 2014), and by working with STEM school leadership to understand and synthesize the work they do (LaForce et al., 2016). The latter was the approach taken in the current study, where partnerships with school leaders from inclusive STEM high schools across the U.S. led to the creation of an overarching theoretical model for STEM schools. This particular framework articulates eight common themes or goals of inclusive STEM schools—referred to as the 8 Elements—that describe the structures enacted in the schools and behaviors engaged in by school staff and students.

The 8 Elements are: 1) Problem-Based Learning (PBL); 2) Rigorous Learning; 3) Personalization of Learning; 4) Career, Technology, and Life Skills; 5) School Community and Belonging; 6) External Community; 7) Staff Foundations; and 8) Essential Factors<sup>1</sup> (LaForce et al., 2016). Each Element is composed of a number of strategies representing the concrete ways that members of inclusive STEM schools and their communities work to reach the schools’ goals; the Elements serve as organizers for understanding the complex innovation of STEM schools, so that we may begin to unpack exactly *how* these schools function to improve student outcomes. In this exploratory study, we begin this work by focusing on the first five Elements, which are the frameworks’ student-facing Elements (i.e., those that directly address the schools’ goals for students).

In our prior work (LaForce et al., 2016), we identified how each Element manifests operationally in inclusive STEM schools. For example, Personalization of Learning may occur through strategies such as student autonomy in the classroom and/or having a dedicated Advisory class. Each student-facing Element is made up of between 10 and 17 strategies; thus, inclusion in this study was determined by three criteria: a) association with one or more student-facing Element(s), as noted above, b) measurement viability (described below under *Measures*), and c) importance to practitioners. The last criterion was determined by identifying the strategies most frequently emphasized in open-ended interview data by inclusive STEM school leaders (LaForce et al., 2016). For example, problem solving projects (PBL Element) and staff supporting the needs of the whole student (including academic, social, and emotional needs; School Community and Belonging Element) were the most frequently emphasized student-facing strategies described by a sample of school leaders as essential to the schools’ missions and goals. The strategies examined, organized by their respective Element(s), and the percent of the sample of school leaders who emphasized each strategy are listed in [Table 1](#). (Note that some strategies are associated with multiple Elements, indicating that these strategies serve multiple goals for students.)

---

<sup>1</sup> The descriptive nature of the 8 Elements framework is critical to note. The Elements were derived directly from conversations with inclusive STEM high school leaders about what the schools do and what defines them as STEM schools; therefore, these Elements and components do not represent a set of strategies we defined or mean to prescribe for schools. Rather, the Elements tell us what established inclusive STEM schools are doing. While many of these practices are rooted in the literature and empirical evidence, it is necessary to investigate the specific strategies to understand if, in the context of STEM schools, they do indeed have the potential to improve student outcomes overall, and to reduce gaps in achievement. See LaForce et al., 2016 for more detail on each of the Elements and the process used to derive them.

**Table 1.** Strategies for Students

Element	Strategy	Percentage of school leaders who emphasized strategy
PBL	Problem solving projects	70%
	Student cooperation and teamwork	60%
	Student autonomy	55%
	Interdisciplinary connections	35%
Rigorous Learning	Interdisciplinary connections	35%
	Cognitively demanding work	30%
Personalization of Learning	Student autonomy	55%
Career, Technology, and Life Skills	Student cooperation and teamwork	60%
	Technology use	45%
School Community and Belonging	Staff support needs of whole student	70%
	Student culture (student trust & respect, student code of behavior and values, students contribute to school decision-making)*	25-40%*

\*Note: Student culture was initially measured by three strategies; these were combined after factor analysis supported a one-factor solution across these measures

## The Current Study

The current study investigated whether implementation of strategies used by inclusive STEM schools predicts students' STEM-related outcomes and academic achievement, and whether these associations differ by student gender identity and race/ethnicity. To do so, we asked the following research questions to begin to understand the specific ways in which inclusive STEM schools might contribute to improved outcomes for students:

1. How do student-facing strategies used by inclusive STEM schools relate to students' science attitudes, interest in STEM, and overall achievement?
2. How do these relationships vary for students of different gender identities and races/ethnicities?

This study moves beyond existing research by looking inside the 'black box' of STEM schools to uncover findings about the specific strategies that may lead to desired student outcomes, and whether these strategies have the potential to decrease existing interest and achievement gaps for populations currently underrepresented in STEM fields.

## METHODS

This paper describes two analyses that were a part of a larger study of inclusive STEM high schools known as "STEM School Study" (NSF# 1238552; see LaForce et al., 2016 for a review). Analysis 1 examines problem-solving projects, supportive relationships, and student culture. Measures for these variables were given to the entire sample of students, as problem-solving projects, supportive relationships, and student culture are variables that students may experience across multiple classes as well as in non-academic settings. Analysis 2 examines student cooperation and teamwork, student autonomy, interdisciplinary connections, cognitively demanding work, and technology use. These measures were administered within a class-specific frame (described below). Because the outcome measures for this study focus on science, we selected students who reported on these measures for their science class, only.

## Sample

**School identification and sample.** Researchers worked with 20 inclusive STEM high schools from seven states over the course of the larger project. Educators and students in these schools were invited to participate in a variety of data collection activities including school leader interviews; teacher interviews, focus groups, and questionnaires; student interviews and questionnaires; and classroom observations. To select schools for participation, we identified seven states with established state-level STEM networks to connect with, as these networks facilitated our ability to recruit schools. Network contacts provided the research team with the names and contacts for a number of schools in their respective states. The final set of schools included four schools each from Ohio, Texas, and Washington, three from California, two from both North Carolina and Tennessee, and one from New York.<sup>2</sup> While the schools varied in their models and missions, and were founded and developed

<sup>2</sup> Detailed school recruitment strategy is available from the authors upon request.

independently of one another, all schools in our sample had significant overlap in terms of the strategies they employed, as represented in the 8 Elements framework (LaForce et al., 2016).

The current analyses draw on student questionnaire data from the final year of data collection (2015), and included 17 of the original 20 schools (due to two schools dropping out of the study after Year One and an additional school having an insufficient sample of students participating in the final year's questionnaire).

**Analysis 1.** Participants in this analysis were 9<sup>th</sup> to 12<sup>th</sup> grade students (33% 9<sup>th</sup>, 28% 10<sup>th</sup>, and 25% 11<sup>th</sup>, and 14% 12<sup>th</sup> graders). The analytic sample consisted of 2,943 students (50% female) who were racially/ethnically diverse (50% White, 36% Hispanic/Latino, and 13% Black).<sup>3</sup> Of the 17 schools, 12 were populated predominantly by students identifying as White; the remaining five schools were populated predominantly by students who identified as Hispanic/Latino. Seven of the schools were suburban, six were urban, and four were rural. The number of respondents in each school ranged from 44 to 619 students.

In addition, a subsample of students with school-provided GPA data ( $N = 944$ ; 39% 9<sup>th</sup>, 34% 10<sup>th</sup>, 20% 11<sup>th</sup>, and 7% 12<sup>th</sup> graders) were examined to explore associations between strategies used by inclusive STEM schools and students' cumulative GPAs. We also explored whether such associations varied based on student gender identity and race/ethnicity. This sample included relatively equal numbers of female (53%) and male students and was racially/ethnicity diverse (46% White, 36% Hispanic/Latino, and 18% Black).

**Analysis 2.** This analysis looked at a sub-sample of 433 9<sup>th</sup> to 12<sup>th</sup> students (24% 9<sup>th</sup>, 39% 10<sup>th</sup>, 21% 11<sup>th</sup>, and 16% 12<sup>th</sup> graders) reporting on classroom-specific strategies in their science classes. On the questionnaire, students were asked to report on the frequency of instructional practices experienced in a specific class (i.e., the class they attended on Monday mornings at 10am). Proportions of students identifying as male/female, as well as race/ethnicity proportions in this sample were similar to Analysis 1 (48% female; 50% White, 38% Hispanic/Latino, and 12.2% Black). We did not examine GPA in this analysis due to insufficient sample size.

#### Measures<sup>4</sup>

**Outcome variables for all studies** (four measures, and all of the items in each measure scored using a six-point Likert scale with higher scores indicating positivity in the attribute being measured (e.g., 1 = strongly disagree, and 6 = strongly agree)):

1) **Science intrinsic motivation:** Four items ( $a = 0.96$ ) derived from the Attitude toward Science in School Assessment (Germann, 1988) were used to assess students' motivation in science (e.g., *I find science very interesting*).

2) **Science ability beliefs:** Four items ( $a = 0.92$ ) were used to assess students' beliefs about their science abilities (e.g., *I have the skills and ability to learn about science*). Items were adapted from the Student Self-Report of Academic Self-Efficacy (Hoover-Dempsey and Sandler, 2005; Patrick, Ryan, and Kaplan 2007).

3) **Interest in future STEM careers:** Four items ( $a = 0.97$ ) developed for the current study were used to assess students' interest in pursuing STEM courses in college and in future careers (e.g., *I see myself pursuing a career in STEM*).

4) **Cumulative GPAs (Analysis 1 only):** Students' cumulative GPAs across all academic subjects was provided by the school districts. Cumulative GPAs was standardized using z-scores across all schools in the sample due to different scales used when reporting students' cumulative GPAs.

**Demographic and control variables.** Students were asked to indicate race/ethnicity, gender identity, grade, and school type (dummy-coded variables: Predominantly Hispanic/Latino schools and Predominantly White schools. No schools in the sample were predominantly African-American).

This study also included one response bias control variable:

**General school intrinsic motivation:** Four items ( $a = 0.86$ ) were used to examine students' motivation toward schoolwork and school in general (e.g., *I enjoy doing my schoolwork*). A six-point Likert scale was used (e.g., 1 = strongly disagree, 6 = strongly agree), with higher scores indicating positivity in the attribute being measured. This variable was included to account for response bias amongst students (i.e., students who typically rate all variables high or low).

<sup>3</sup> Across both Analyses 1 and 2, samples included students who identified as other race/ethnicities (e.g. Native American/American Indian, Mixed Race) and/or non-binary gender identities; however, the number of these students was insufficient to include as variables in these analyses.

<sup>4</sup> All attitudinal measures (predictor and outcome variables) were developed and revised across the three years of questionnaire administration. The measures utilized in the present study represent final instruments administered in Year 3 (2014-2015). Further data and documentation on the validation and adaptation of these measures can be obtained from the authors upon request.



**Key Variables.** As noted, measures were selected for their prominence in school leaders' descriptions of their respective STEM school models. In addition, measures were also required to meet viability criteria. To maximize power, variability, and reliability, we included only items with a Likert-type scale of 5 response options or more, and a Cronbach's alpha of 0.75 or higher.

Moreover, it is beyond the scope of this paper to thoroughly summarize the literature on each of the strategies outlined here. Instead, we provide a brief summary of each element, describe how it was measured, and share additional resources providing support for each strategy. While evidence of the efficacy of several of these strategies exists, they are relatively understudied in inclusive STEM school contexts. It is important to keep in mind that the goal of this study is to better understand how such strategies work alongside many other strategies in the context of the inclusive STEM schools.

In Analysis 1, key variables were included as (Items in each measure were scored on a six-point Likert scale (e.g., 1 = *Never*, 6 = *Always*)):

1) **Problem-solving projects measure.** A key strategy for PBL is problem-solving projects, which we define as curriculum which includes projects, often interdisciplinary, focused on solving an authentic problem (LaForce et al., 2016). Problem-solving projects may occur within one class, across several classes, or as part of a dedicated timeframe during the school year where students work solely on a specific project (LaForce, Noble, and Blackwell, 2017; for a review, see Savery and Duffy, 1995). Twelve items ( $\alpha = 0.96$ ) derived from previous research (Munshi, El Zayat, and Dolmans, 2008; Savery, 2006) were adapted for use with high school-age students and used to capture the frequency with which students reported experiencing various aspects of PBL at their school (e.g., *How often do you engage in PBL activities that are interesting and relevant to your lives?*).

2) **Supportive relationships measure.** Supportive relationships posit that students feel that their emotional and academic needs are supported by adults at their school (e.g., teachers, leadership, and other school staff). Previous research has found associations between supportive student-teacher relationships and student engagement, and academic achievement (Roorda, Koomen, Spilt, and Oort, 2011; Wu, Hughes, and Kwok, 2010). Six items ( $\alpha = 0.96$ ) developed for the study were used to assess the extent to which students felt supported by teachers and school leaders (e.g., *Adults understand students' lives outside of school and take them into account when teaching*).

3) **Student culture measure.** Student culture, including mutual trust and respect, adherence to a code of behavior and values, and contribution to school-wide decision-making, plays a role in students' ability to function at optimal levels needed to achieve academic success in STEM disciplines (Wang, Haertel, and Walberg, 1997). An exploratory factor analysis of three separate measures supported a one-factor solution for this 10-item measure ( $\alpha = 0.94$ ). Items assessed students' value systems within their school (e.g., *Students always demonstrate good school citizenship*), respectful behaviors (e.g., *Even when they disagree, students at this school still treat each other with respect*), and decision-making opportunities (e.g., *Students at this school participate in important, whole-school decisions*).

In Analysis 2, five science classroom-specific measures were included as (All items used for each measure were scored using a six-point Likert scale (e.g., 1 = *No classes*, 6 = *More than once in every class session*):

1) **Autonomy.** Being autonomous is defined as students showing independence in and ownership of their learning, setting their own goals for learning, and making choices about how to accomplish those goals. Autonomy has been linked to student engagement (Reeve, Jang, Carrell, Jeon, and Barch, 2004), as well as interest and perceived competence in science (Black and Deci, 2000). Four items ( $a = 0.79$ ) were used to assess student autonomy (e.g., *I set my own goals for learning*).

2) **Cognitively demanding work.** Engaging in cognitively-demanding work refers to students' ability to use critical thinking and processing skills, to make alternative arguments or explanations, to make predictions, to interpret experiences, to analyze data, to explain reasoning, and to support conclusions with evidence. These types of skills are important for scientific reasoning and effective problem solving in academic, social, and personal settings (Halpern, 1999; Shakirova, 2007). Four items ( $a = 0.87$ ) were used to explore students' engagement in cognitively demanding work (e.g., *I supported my conclusions with evidence*).

3) **Interdisciplinary content.** Making interdisciplinary connections refers to students' possessing the ability to identify the ways in which academic disciplines are interrelated, reinforced, and complement one another. The interdisciplinary nature of learning and knowledge, and the importance of students' understanding of this and their ability to make cross-disciplinary connections, is well-recognized (NGSS Lead States, 2013; Partnership for 21<sup>st</sup> Century Learning, 2015). Three items ( $a = 0.88$ ) were used to examine the frequency with which content taught in science classes was transferable to other subjects (e.g., *I used information or content from another subject in an assignment or activity for this class*).

4) **Technology use.** Using technology in an appropriate manner refers not only to students' use of technology in the classroom, but also to their use of emerging and innovative technologies for meaningful learning. Given the ubiquity of technology in daily life and modern workplaces, incorporating its use in the classroom and promoting students' digital literacy and technical abilities is critical (U.S. Department of Education, 2017). Three

items ( $\alpha = 0.84$ ) were used to assess the use of innovative technology in learning (e.g., *I had all of the technological resources needed to complete assignments/ reach goals*).

5) **Cooperation and teamwork:** The ability to collaborate and work as part of a team is considered by inclusive STEM schools to be a critical workplace and 21<sup>st</sup> century skill for all students (Partnership for 21<sup>st</sup> Century Learning, 2015). Four items ( $\alpha = 0.85$ ) were used to assess the degree of teamwork among students (e.g., *Another student helped me with an assignment or problem that I was struggling with*).

## Procedure

Teachers at sample schools administered the online student questionnaire between February and May, 2015, during the school day. The questionnaire took approximately 25 minutes for students to complete and addressed a range of school experiences and attitudes.

## Analytic Strategy

Multiple regression in the Statistical Package for the Social Sciences © (SPSS) Version 24 was conducted to examine associations between strategies used by inclusive STEM schools and STEM-related attitudes and achievement outcomes. Separate linear regression models were used to investigate students' science intrinsic motivation, science ability beliefs, interest in future STEM careers, and cumulative GPAs, which served as the dependent variables. In these regression models, main effects were entered in blocks as follows: 1) Student demographics, including gender identity (male served as the reference group), race/ethnicity (White served as the reference group), and grade level (9<sup>th</sup> grade as the reference group); 2) students' general motivation toward school; 3) Student experiences with problem-solving projects, student culture, and supportive relationships, *or* classroom-specific science strategies. Interaction terms (e.g., problem solving project by gender) were added to the regression models to investigate whether associations between the strategies used and attitudinal and academic achievement outcomes varied across different groups of students. To create the interaction terms for these analyses, all continuous main effect variables were first centered by subtracting the sample mean to create a new mean of zero. Three-level moderator variables, specifically race/ethnicity, were dummy coded, such that White students served as the reference group. Interaction terms were then created by multiplying the centered continuous main effect variables with each of the moderator variables (Frazier, Tix, and Barron, 2004). The Interaction program for Windows (Soper, 2006-2013) was used to depict significant interaction terms that emerged. Holm-Bonferroni sequential correction was adopted to control for Type I Error (Holm, 1979).

## RESULTS

### Analysis 1: Problem-Solving Projects, Student Culture, and Supportive Relationships and STEM-related Attitudes

Specific  $F$  statistics, degrees of freedom, and adjusted  $R^2$  for STEM-related attitudes and academic achievement (cumulative GPA) are included in [Table 2](#) and [3](#).

Females rated STEM-related attitudes (i.e., science intrinsic motivation, science ability beliefs, and interest in future STEM career) significantly lower than males. Compared to White students, Black students reported significantly lower scores on science intrinsic motivation. Twelfth graders reported significantly lower scores on science intrinsic motivation and interest in future STEM careers than 9<sup>th</sup> graders, whereas 10<sup>th</sup> graders rated interest in future STEM careers significantly lower than 9<sup>th</sup> graders. Higher levels of general school intrinsic motivation were significantly associated with higher scores on all three STEM-related attitudes. Higher ratings of problem-solving projects were significantly associated with higher scores on science intrinsic motivation and science ability beliefs. Significant main effects of race/ethnicity and completion of problem-solving projects on interest in future STEM careers were qualified by a significant race/ethnicity by problem-solving projects interaction. White students ( $\beta = .41, SE = .03, p < .001, CI95\%: [.35, .47]$ ) with higher ratings of problem-solving projects were more likely to have higher interest in future STEM careers than Hispanic/Latino students ( $\beta = .23, SE = .04, p < .001, CI95\%: [.15, .30]$ ). A significant interaction was also observed between supportive relationships and race/ethnicity for science ability beliefs. In this case, Hispanic/Latino students ( $\beta = .33, SE = .03, p < .001, CI95\%: [.27, .39]$ ) with higher ratings of supportive relationships also reported higher ratings of science ability beliefs compared to White students ( $\beta = .30, SE = .02, p < .001, CI95\%: [.25, .35]$ ). See [Table 2](#) for estimates for all variables included in this regression model.

**Table 2.** Multiple Regression Results for Outcome Variables: Problem-solving projects, student culture, supportive relationships

	Science Intrinsic Motivation			Science Ability Beliefs			Interest in Future STEM Careers			Cumulative GPA		
	<i>B</i>	<i>SE</i>	$\beta$	<i>B</i>	<i>SE</i>	$\beta$	<i>B</i>	<i>SE</i>	$\beta$	<i>B</i>	<i>SE</i>	$\beta$
Female	-.24**	.04	-.09	-.38**	.04	-.16	-.43**	.05	-.15	.22**	.06	.11
Black	-.29**	.07	-.08	-.13	.06	-.04	-.10	.08	-.02	-.60**	.09	-.23
Hispanic/Latino	-.15	.06	-.05	-.17*	.05	-.07	.13	.07	.04	-.17	.09	-.08
10th Grade	-.09	.05	-.03	-.09	.05	-.04	-.17*	.06	-.05	-.06**	.07	-.03
11th Grade	-.11	.06	-.04	-.09	.05	-.04	-.05	.06	-.01	-.28**	.09	-.11
12th Grade	-.23**	.07	-.06	-.13	.06	-.04	-.26**	.08	-.06	-.57	.13	-.15
General School Motivation	.45**	.02	.39	.33**	.02	.33	.43**	.03	.33	.06	.03	.07
School Type	.04	.06	.01	.08	.05	.03	-.07	.07	-.02	-.04	.08	-.02
Problem-solving Projects (PSP)	.11*	.03	.10	.13**	.03	.13	.15**	.04	.12	.02	.05	.03
Student Culture (SC)	.06	.04	.05	.07	.04	.07	.06	.05	.04	-.03	.06	-.04
Supportive Relationships (SR)	-.02	.04	-.02	-.05	.04	-.05	.01	.05	.01	.18*	.07	.19
PSP*Female	.05	.04	.03	.01	.04	.01	.03	.05	.02	.02	.06	.02
PSP*Black	.04	.07	.01	.11	.06	.04	.03	.08	.01	-.09	.09	-.04
PSP*Hispanic/Latino	-.03	.04	-.02	.00	.04	.00	-.15*	.05	-.07	.01	.07	.01
SC*Female	-.02	.05	-.01	.03	.04	.02	.05	.06	.02	.02	.07	.02
SC*Black	.01	.08	.00	-.05	.07	-.02	.04	.09	.01	.14	.10	.07
SC*Hispanic/Latino	.00	.05	.00	-.06	.05	-.04	.06	.06	.03	.23*	.08	.15
SR*Female	.01	.05	.00	.06	.04	.04	.03	.06	.01	-.12	.07	-.09
SR*Black	.15	.07	.05	.10	.07	.03	.05	.09	.01	-.08	.10	-.04
SR*Hispanic/Latino	.13	.05	.07	.13*	.05	.07	.08	.06	.04	.01	.08	.01
<i>F</i> statistics ( <i>df</i> ) Adjusted R <sup>2</sup> (R <sup>2</sup> change)	54.48** (20, 2944)			47.39** (20, 2935)			44.37** (20, 2932)			8.72** (20, 923)		
	.27 (.27)			.24 (.24)			.23 (.23)			.14 (.16)		

\* $p < 0.05$ , \*\* $p < 0.01$ ,  $\beta$ -unstandardized, *b*-standardized, significant *p* values were corrected using Holm-Bonferroni method. PSP = problem-solving projects, SC = student culture, SR = supportive relationships

### Academic Achievement (cumulative GPAs)

Females had significantly higher cumulative GPAs than males, and Black students had significantly lower cumulative GPAs compared to White students. Ninth grade students had significantly higher cumulative GPAs compared to 11th and 12th graders. Supportive relationships were associated with higher cumulative GPAs. A significant race/ethnicity by student culture interaction were found on cumulative GPAs: Hispanic students ( $\beta = .32$ ,  $SE = .05$ ,  $p < .001$ ,  $CI95\%$ : [.23, .42]) had a higher cumulative GPAs than White students ( $\beta = .12$ ,  $SE = .04$ ,  $p = .001$ ,  $CI95\%$ : [.05, .19]) (Table 2).

### Analysis 2: Science-specific Classroom Measures and STEM-related Attitudes

Three separate models were conducted to examine associations between each instructional practice (i.e., student autonomy, cognitively demanding work, interdisciplinary content, technology use, and student teamwork) and science intrinsic motivation, science ability beliefs, and interest in future STEM careers. General school intrinsic motivation (response bias control) was positively associated with all three outcome variables. A significant race/ethnicity by cognitively-demanding work interaction emerged for science intrinsic motivation. Black students ( $\beta = .51$ ,  $SE = .05$ ,  $p < .001$ ,  $CI95\%$ : [.26, .76]) with higher ratings of cognitively-demanding work reported higher levels of science intrinsic motivation compared to White students ( $\beta = .31$ ,  $SE = .05$ ,  $p < .001$ ,  $CI95\%$ : [.21, .41]). See Table 3 for estimates for all variables included in this regression model.

## DISCUSSION

This study explores how strategies used by inclusive STEM schools may work to improve outcomes for students, and particularly those currently underrepresented in STEM. In doing so, it is one of the first studies to demonstrate the potential value of those strategies within the context of inclusive STEM schools. Other studies examining student outcomes of STEM schools (such as Gnagey and Lavertu, 2016) do not look at student outcomes as a function of the strategies used *within STEM schools*; instead, they focus on comparisons between STEM and non-STEM schools. Our research complements these between-schools comparison studies by providing a deeper look within the 'black box' of inclusive STEM schools to explore how specific strategies may be contributing to student outcomes.

**Table 3.** Multiple Regression Results for Outcome Variables: Science-specific Classroom Measures

	Science Intrinsic Motivation			Science Ability Beliefs			Interest in Future STEM Careers		
	<i>B</i>	<i>SE</i>	$\beta$	<i>B</i>	<i>SE</i>	$\beta$	<i>B</i>	<i>SE</i>	$\beta$
Female	-0.08	0.11	-0.03	-0.19	0.10	-0.08	-0.34	0.13	-0.11
Black	-0.34	0.18	-0.09	-0.20	0.17	-0.06	-0.50	0.21	-0.11
Hispanic/Latino	0.05	0.15	0.02	-0.07	0.14	-0.03	0.04	0.18	0.01
10th Grade	-0.09	0.14	-0.03	-0.09	0.13	-0.04	-0.16	0.16	-0.05
11th Grade	-0.16	0.16	-0.05	-0.10	0.15	-0.04	-0.03	0.19	-0.01
12th Grade	-0.28	0.18	-0.09	-0.23	0.17	-0.08	-0.28	0.21	-0.07
General School Motivation	0.36**	0.05	0.37	0.34**	0.04	0.38	0.55**	0.06	0.47
School Type	-0.07	0.15	-0.03	0.03	0.14	0.01	0.12	0.17	0.04
Autonomy	0.08	0.09	0.07	-0.04	0.09	-0.03	0.03	0.11	0.02
Cognitively Demanding Work	0.11	0.10	0.11	0.15	0.10	0.15	0.20	0.12	0.16
Interdisciplinary Content	0.04	0.09	0.04	-0.10	0.09	-0.11	-0.02	0.11	-0.02
Technology Use	-0.03	0.07	-0.03	0.10	0.07	0.11	0.06	0.09	0.05
Student Teamwork	-0.01	0.10	-0.01	-0.07	0.10	-0.06	-0.15	0.12	-0.10
Autonomy*Female	0.30	0.13	0.17	0.23	0.12	0.14	0.22	0.15	0.10
Autonomy*Black	-0.32	0.20	-0.10	0.08	0.19	0.03	-0.38	0.24	-0.09
Autonomy*Hispanic/Latino	-0.15	0.13	-0.08	0.07	0.12	0.04	0.04	0.15	0.02
CDW*Female	-0.29	0.13	-0.20	-0.11	0.12	-0.08	-0.31	0.15	-0.17
CDW* Black	0.66*	0.24	0.23	0.04	0.23	0.01	-0.03	0.29	-0.01
CDW*Hispanic/Latino	0.17	0.13	0.10	-0.12	0.12	-0.08	-0.26	0.15	-0.13
IC*Female	0.11	0.11	0.08	0.20	0.10	0.16	0.13	0.13	0.08
IC*Black	-0.18	0.18	-0.07	0.04	0.17	0.02	0.06	0.22	0.02
IC*Hispanic/Latino	0.01	0.12	0.00	0.12	0.12	0.08	0.08	0.14	0.04
Technology Use *Female	-0.01	0.10	-0.01	0.05	0.09	0.04	-0.01	0.11	-0.01
Technology Use *Black	0.12	0.17	0.05	0.03	0.17	0.01	0.20	0.21	0.06
Technology Use *Hispanic/Latino	0.01	0.10	0.01	-0.04	0.10	-0.03	-0.01	0.12	-0.01
Student Teamwork *Female	-0.05	0.13	-0.03	-0.10	0.13	-0.06	0.17	0.16	0.08
Student Teamwork *Black	-0.23	0.21	-0.07	-0.07	0.20	-0.02	0.38	0.25	0.09
Student Teamwork *Hispanic/Latino	0.09	0.14	0.05	0.06	0.13	0.03	0.18	0.17	0.08
<i>F</i> statistics ( <i>df</i> )	6.31** (28, 402)			5.39** (28, 402)			7.64** (28, 402)		
Adjusted R <sup>2</sup> (R <sup>2</sup> change)	.26 (.31)			.22 (.27)			.30 (.35)		

\* $p < 0.05$ , \*\* $p < 0.01$ ,  $\beta$ -unstandardized, *b*-standardized, significant *p* values were corrected using Holm-Bonferroni method. CDW = cognitively-demanding work, IC = interdisciplinary content

Additionally, this study contributes to our understanding of the implications of strategies used in inclusive STEM schools for students of different races/ethnicities and gender identities. Because arguably one of the central goals of inclusive STEM schools is to diversify the STEM workforce, it is imperative to understand how student outcomes manifest across a diverse body of inclusive STEM school students. Our findings suggest that while some strategies used by inclusive STEM schools are associated with positive attitudes toward science and STEM careers (and in some cases, GPA) for all or some students, these strategies are not sufficient to reduce race and gender gaps. Within inclusive STEM high schools in this study, Black and Hispanic/Latino students still fall below White students in attitudes and achievement. Girls consistently demonstrate higher GPA than males, though they continue to show less positive attitudes towards science and STEM careers. In addition, results indicate that White students receive disproportional benefits from completion of problem-solving projects compared to Hispanic/Latino students.

However, when students report strong, positive experiences with certain strategies used by inclusive STEM schools, there may be potential to narrow some gaps. For instance, Hispanic/Latino students who reported higher ratings of supportive relationships also reported significantly higher ratings of science ability beliefs compared to White students. This result suggests that supportive relationships may have the potential to boost Hispanic/Latino students' science ability beliefs. This finding aligns with Benner et al. (2017) who found that caring environments and positive connections with educators may be particularly beneficial for ethnic minority youth. Moreover, Hispanic/Latino students who reported higher levels of student culture had higher GPAs than White students who reported the same levels of student culture. This finding also echoes previous studies that have found significant effects of supportive teacher and school staff relationships on high school students' success (Croninger and Lee, 2001; Benner, Boyle, and Bakhtiari, 2017). In general, supportive relationships and positive student culture may enhance student happiness and/or mental health, and subsequently attitudes *and* achievement (Dix, Slee, Lawson, and Keeves, 2012). These effects may be particularly critical for students who are marginalized in US classrooms. Marginalized students may benefit more from relationships that help build social capital than non-

marginalized students, who may, by definition, have more access to social capital (e.g., useful networks and support) in their education (Fields, 2017).

Furthermore, we examined associations between specific classroom strategies enacted in science classes with a smaller sample of students (i.e., those who reported on their science class, as opposed to reporting on another subject). Female students had significantly lower interest in future STEM careers than males, whereas Black students has higher levels of science intrinsic motivation when they reported engaging in cognitively-demanding work more often in their science classes. This finding may suggest that rigorous teaching, with an emphasis on critical thinking and reasoning skills, in science classes may provide a potential benefit for Black students. Emphasizing cognitively-demanding work in such classroom settings may provide opportunities for students to engage more deeply with science curriculum through carrying out higher levels of interpretation, flexibility, and construction (Tekkumru-Kisa, Stein, and Schunn, 2015).

Across analyses, we often saw a negative association between students' grade level and science attitudes, which may be linked to students becoming more in-tune with their abilities, and also, having more opportunities to explore, their interests as they progress through school. Young inclusive STEM high school students may be excited for all of what STEM and science can offer, and over time, they may realize that it is not a core interest, or that they would rather pursue other courses consistent with their academic abilities. Future research is necessary to disentangle this finding further, and to better understand age-related, developmental correlates of science attitudes.

### Future Directions

This study contributes to a growing body of research exploring associations between inclusive STEM school strategies and student outcomes. While findings here suggest some preliminary evidence for the usefulness of a number of the inclusive STEM school strategies identified in the 8 Elements Framework (LaForce et al., 2016), further research is needed to better understand the impact of such strategies on diverse populations of students. For example, the data presented here are cross-sectional, collected through a correlational research design, which prevents causal inferences from being drawn. Future studies could incorporate more-rigorous (i.e., longitudinal and experimental) research designs to gather information about growth and change of students STEM attitudes and exposure to STEM school strategies. Future studies also need to continue to dig into the 'black box' of inclusive STEM schools to understand which strategies, and what characteristics of them, truly benefit underrepresented groups students. Finally, additional research must be done to examine success indicators of inclusive STEM schools beyond test scores and student attitudes toward science, such as postsecondary transition, persistence with STEM majors, and matriculation to STEM careers immediately after high school.

### Limitations

The results of the current study must be interpreted in light of several limitations. First of all, although this study takes a critical first step in examining strategies used by inclusive STEM schools in context, statistical limitations (e.g., investigating large number of variables through a set of models) prevented us from analyzing all strategies simultaneously. It should also be noted that the use of Holm-Bonferroni correction to account for Type I Error limited the number of significant findings that were reported. Thus, larger sample sizes may be necessary to identify all possible associations between strategies used by inclusive STEM schools and student outcomes. Additionally, while we see evidence of success across several individual strategies studied here, less is known about which strategies may be *most* critical to student outcomes, as well as how these strategies work together within the inclusive STEM school setting. Given the complex tapestry of strategies used by inclusive STEM schools, this will be a challenge for researchers to study in the future; the strategies (and outcomes) in this study, while extensive, are by no means exhaustive of what inclusive STEM school creators and leaders consider critical. Furthermore, the use of students' cumulative GPA rather than annual GPA is a limitation. Students' annual GPA, more proximal to the strategies students experienced and reported on at the time of the questionnaire, would be a more ideal achievement outcome variable, rather than cumulative GPA, which is a function of several years of schooling, and thus holds a larger potential for uncontrolled variability. Finally, it is also important to note that this paper reflects implementation as measured by the student voice. We, along with others, would argue that students provide a critical voice in understanding implementation (Cook-Sather, 2006); however, it is only one form of implementation measurement, and capturing teachers', parents', and school district administrators' voices will be an important future direction of this research. Finally, this study did not include the use of interaction terms to examine intersectionality between different groups (e.g., gender, and race/ethnicity) of students. Future research should investigate intersectionality within these groups of students (e.g., African American female students) in order to gain a better understanding of how dual-identities contribute to students' science ability beliefs, intrinsic motivation, and interest in future STEM careers.



## Summary Conclusions

In summary, we see the potential of inclusive STEM school strategies, as well as clear areas for future work. Many strategies used in inclusive STEM schools, when implemented well in such settings, show promise for improving student attitudes towards and interest in STEM, and for reducing some of the long-standing gender and race/ethnicity gaps seen in STEM education. However, within our sample of inclusive STEM schools, who seek in part to provide equitable STEM outcomes for all students, we still see significant and disappointing race and gender gaps in these outcomes. These findings should be considered alongside comparison studies investigating inclusive STEM schools and non-STEM schools that show, at best, varying levels of success for underrepresented students (Means et al., 2017; Gnagey and Lavertu, 2016). While STEM schools seem to be successful at providing a diverse body of students with *access* to an environment that promotes STEM success, access alone may not be sufficient to eliminate gaps in science attitudes and GPA across race/ethnicity and gender identity. As demonstrated in this study, when students have strong ratings of STEM school strategies – some gaps may diminish, which suggests the potential of these schools, and their associated strategies, to contribute in meaningful ways to the STEM workforce issues at hand in the U.S. Researchers, practitioners, and school district administrations striving to close long-standing gender and race/ethnicity education gaps should not overlook the importance of these implications when it comes to correcting and closing long-standing educational gaps between diverse members of our society.

## REFERENCES

- Anderson, E. L. and Kim, D. (2006). *Increasing the success of minority students in science and technology* (No. 4). Washington, DC: American Council on Education.
- Bandura, A. (1997). *Self-Efficacy: The Exercise of Control*. New York, NY: W. H. Freeman.
- Benner, A.D., Boyle, A.E. and Bakhtiari, F. (2017). Understanding students' transition to high school: Demographic variation and the role of supportive relationships. *Journal of Youth Adolescence*, 46(10), 2129-2142. <https://doi.org/10.1007/s10964-017-0716-2>
- Bicer, A., Navruz, B., Capraro, R. M., Capraro, M. M., Oner, T. and Boedeker, P. (2015). STEM schools vs. non-STEM schools: Comparing students' mathematics growth rate on high-stakes test performance. *International Journal on New Trends in Education and Their Implications*, 6(1), 138-150.
- Black, A. E. and Deci, E. L. (2000). The effects of instructors' autonomy support and students' autonomous motivation on learning organic chemistry: A self-determination theory perspective. *Science Education*, 84(6), 740-756. [https://doi.org/10.1002/1098-237X\(200011\)84:6<740::AID-SCE4>3.0.CO;2-3](https://doi.org/10.1002/1098-237X(200011)84:6<740::AID-SCE4>3.0.CO;2-3)
- Britner, S. L. and Pajares, F. (2001). Self-efficacy beliefs, motivation, race, and gender in middle school science. *Journal of women and Minorities in Science and Engineering*, 7(4), 271-285. <https://doi.org/10.1615/JWomenMinorScienEng.v7.i4.10>
- Burrus, J., Jackson, T., Xi, N. and Steinberg, J. (2013). Identifying the most important 21st century workforce competencies: An analysis of the Occupational Information Network (O\* NET). *ETS Research Report Series*. Available at: <https://onlinelibrary.wiley.com/doi/pdf/10.1002/j.2333-8504.2013.tb02328.x>
- Committee on STEM Education National Science and Technology Council (2013). *Federal Science, Technology, Engineering, and Mathematics (STEM) Education: 5-year Strategic Plan*. Available at: [http://www.whitehouse.gov/sites/default/files/microsites/ostp/stem\\_stratplan\\_2013.pdf](http://www.whitehouse.gov/sites/default/files/microsites/ostp/stem_stratplan_2013.pdf)
- Cook-Sather, A. (2006). Sound, presence, and power: "Student voice" in educational research and reform. *Curriculum Inquiry*, 36(4), 359-390. <https://doi.org/10.1111/j.1467-873X.2006.00363.x>
- Croninger, R. G. and Lee, V. E. (2001). Social capital and dropping out of high school: Benefits to at-risk students of teachers' support and guidance. *Teachers College Record*, 103(4), 548-581. <https://doi.org/10.1111/0161-4681.00127>
- Dix, K. L., Slee, P. T., Lawson, M. J. and Keeves, J. P. (2012). Implementation quality of whole - school mental health promotion and students' academic performance. *Child and Adolescent Mental Health*, 17(1), 45-51. <https://doi.org/10.1111/j.1475-3588.2011.00608.x>
- Eccles, J. S. and Wigfield, A. (2002). Motivational beliefs, values, and goals. *Annual Review of Psychology*, 53, 109-132. <https://doi.org/10.1146/annurev.psych.53.100901.135153>
- Else-Quest, N. M., Mineo, C. C. and Higgins, A. (2013). Math and science attitudes and achievement at the intersection of gender and ethnicity. *Psychology of Women Quarterly*, 37(3), 293-309. <https://doi.org/10.1177/0361684313480694>
- Fields, N. I. (2017). The contribution of urban 4-H to social capital and implications for social justice, *Journal of Extension*, 55(6). Available at: [https://www.joe.org/joe/2017december/pdf/JOE\\_v55\\_6a1.pdf](https://www.joe.org/joe/2017december/pdf/JOE_v55_6a1.pdf)



- Fortus, D. (2014). Attending to affect. *Journal of Research in Science Teaching*, 51(7), 821-835. <https://doi.org/10.1002/tea.21155>
- Frazier, P. A., Tix, A. P. and Barron, K. E. (2004). Testing moderator and mediator effects in counseling psychology research. *Journal of Counseling Psychology*, 51(1), 115-134. <https://doi.org/10.1037/0022-0167.51.1.115>
- Germann, P. J. (1988). Development of the attitude toward science in school assessment and its use to investigate the relationship between science achievement and attitude toward science in school. *Journal of Research in Science Teaching*, 25(8), 689-703. <https://doi.org/10.1002/tea.3660250807>
- Gnagey, J. and Lavertu, S. (2016). The impact of inclusive STEM high schools on student achievement. *AERA Open*, 2(2), 1-21. <https://doi.org/10.1177/2332858416650870>
- Greene, B. A. and Miller, R. B. (1996). Influences on achievement: Goals, perceived ability, and cognitive engagement. *Contemporary Educational Psychology*, 21(2), 181-192. <https://doi.org/10.1006/ceps.1996.0015>
- Halpern, D. F. (1999). Teaching for critical thinking: Helping college students develop the skills and dispositions of a critical thinker. *New Directions for Teaching and Learning*, 1999(80), 69-74. <https://doi.org/10.1002/tl.8005>
- Hansen, M. (2013). *Characteristics of Schools Successful in STEM: Evidence from Two States Longitudinal Data*. Washington, DC: American Institutes of Research. Available at: [http://www.caldercenter.org/publications/upload/WP-97\\_final.pdf](http://www.caldercenter.org/publications/upload/WP-97_final.pdf)
- Hanson, S. L. (2006). African American women in science: Experiences from high school through the post-secondary years and beyond. In J. Bystydzienski and S. Bird (Eds.), *Removing Barriers: Women in Academic Science, Technology, Engineering, and Mathematics* (pp. 123-141). Bloomington: Indiana University Press.
- Holm, S. (1979). A simple sequentially rejective multiple test procedure. *Scandinavian Journal of Statistics*, 6(2), 65-70.
- Hoover-Dempsey, K.V. and Sandler, H.M. (2005). Final Performance Report for OERI Grant # R305T010673: The Social Context of Parental Involvement: A Path to Enhanced Achievement. Presented to Project Monitor, Institute of Education Sciences, U.S. Department of Education. Available at: <https://ir.vanderbilt.edu/bitstream/handle/1803/7595/OERIIESfinalreport032205.pdf?sequence=1>
- Hurtado, S., Eagan, K. and Chang, M. (2010). Degrees of success: Bachelor's degree completion rates among initial STEM majors. Higher Education Research Institute, University of California, Los Angeles.
- LaForce, M., Noble, E., and Blackwell, C. (2017). Problem-based learning (PBL) and student interest in STEM careers: The roles of motivation and ability beliefs. *Education Sciences*, 7(4), 1-22.
- LaForce, M., Noble, E., King, H., Century, J., Blackwell, C., Holt, S., . . . Loo, S. (2016). The eight essential elements of inclusive STEM high schools. *International Journal of STEM Education*, 3(1), 1-11.
- Maltese, A. V. and Tai, R. H. (2009). Eyeballs in the fridge: Sources of early interest in science. *International Journal of Science Education*, 32(5), 669-685. <https://doi.org/10.1080/09500690902792385>
- Martin, M. O., Mullis, I. V. S., Foy, P. and Hooper, M. (2016). *TIMSS 2015 International Results in Science*. Available at: <http://timssandpirls.bc.edu/timss2015/international-results/>
- Mau, W. C. (2003). Factors that influence persistence in science and engineering career aspirations. *Career Development Quarterly*, 51, 234-243. <https://doi.org/10.1002/j.2161-0045.2003.tb00604.x>
- Means, B., Wang, H., Wei, X., Lynch, S., Peters, V., Young, V. and Allen, C. (2017). Expanding STEM opportunities through inclusive STEM-focused high schools. *Science Education*, 101(5), 681-715. <https://doi.org/10.1002/sce.21281>
- Means, B., Wang, H., Young, V., Peters, V. L. and Lynch, S. J. (2016). STEM-focused high schools as a strategy for enhancing readiness for postsecondary STEM programs. *Journal of Research in Science Teaching*, 53(5), 709-736. <https://doi.org/10.1002/tea.21313>
- Munshi, F. M., El Zayat, S. A. and Dolmans, D. H. (2008). Development and utility of a questionnaire to evaluate the quality of PBL problems. *South East Asian Journal of Medical Education*, 2(2), 32-40.
- National Assessment of Educational Progress. (2015a). *2015 Mathematics & Reading Assessments: National Achievement Level Results*. Available at: [https://www.nationsreportcard.gov/reading\\_math\\_2015/#mathematics/ac](https://www.nationsreportcard.gov/reading_math_2015/#mathematics/ac)
- National Assessment of Educational Progress. (2015b). *2015 Science Assessment: National Achievement Level Results*. Available at: [https://www.nationsreportcard.gov/science\\_2015/#ac](https://www.nationsreportcard.gov/science_2015/#ac)
- National Center for Education Statistics (2013). *The Nation's Report Card: Trends in Academic Progress 2012*. Washington, DC: U.S. Department of Education, National Center for Education Statistics.
- National Research Council. (2011). *Successful K-12 STEM Education: Identifying Effective Approaches in Science, Technology, Engineering, and Mathematics*. Washington, DC: National Academy Press.
- National Science Board. (2016). *Science and engineering indicators 2016*. Arlington, VA: National Science Foundation (NSB 16-01).
- National Science Foundation. (2017). *Women, Minorities, and Persons with Disabilities in Science and Engineering: 2017*. Special Report NSF 17-310. National Center for Science and Engineering Statistics. Arlington, VA. Available at: [www.nsf.gov/statistics/wmpd/](http://www.nsf.gov/statistics/wmpd/)

- NGSS Lead States. (2013). *Next Generation Science Standards: For States, By States*. Washington, DC: The National Academies Press.
- Pajares, F. (2005). Gender difference in mathematics self-efficacy beliefs. In A. M. Gallagher and J. C. Kaufman (eds.), *Gender Differences in Mathematics: An Integrative Psychological Approach* (pp. 294-315). New York: Cambridge University Press. <https://doi.org/10.1017/CBO9780511614446.015>
- Partnership for 21<sup>st</sup> Century Learning. (2015). *P21 Framework Definitions*. Available at: [http://www.p21.org/storage/documents/docs/P21\\_Framework\\_Definitions\\_New\\_Logo\\_2015.pdf](http://www.p21.org/storage/documents/docs/P21_Framework_Definitions_New_Logo_2015.pdf)
- Patrick, H., Ryan, K. and Kaplan, A. (2007). Early Adolescents' perceptions of the classroom social environment, motivational beliefs, and engagement. *Journal of Educational Psychology*, 99(1), 83-98 <https://doi.org/10.1037/0022-0663.99.1.83>
- Peters-Burton, E. E., Lynch, S. J., Behrend, T. S. and Means, B. B. (2014). Inclusive STEM high school design: 10 critical components. *Theory into Practice*, 53(1), 64-71. <https://doi.org/10.1080/00405841.2014.862125>
- Reardon, S. F., Robinson, J. P. and Weathers, E. S. (2014). Patterns and trends in racial/ethnic and socioeconomic academic achievement gaps. In H. A. Ladd and E. B. Fiske (Eds.), *Handbook of Research in Education Finance and Policy* (2<sup>nd</sup> Edition) (pp. 1-29). Lawrence Erlbaum.
- Reeve, J., Jang, H., Carrell, D., Jeon, S. and Barch, J. (2004). Enhancing students' engagement by increasing teachers' autonomy support. *Motivation and Emotion*, 28(2), 147-169. <https://doi.org/10.1023/B:MOEM.0000032312.95499.6f>
- Riegle-Crumb, C., Moore, C. and Ramos-Wada, A. (2011). Who wants to have a career in science or math? Exploring adolescents' future aspirations by gender and race/ethnicity. *Science Education*, 95(3), 458-476. <https://doi.org/10.1002/sce.20431>
- Roorda, D. L., Koomen, H. M., Spilt, J. L. and Oort, F. J. (2011). The influence of affective teacher-student relationships on students' school engagement and achievement: A meta-analytic approach. *Review of Educational Research*, 81(4), 493-529. <https://doi.org/10.3102/0034654311421793>
- Ryan, R. M. and Deci, E. L. (2000). Intrinsic and extrinsic motivations: Classic definitions and new directions. *Contemporary Educational Psychology*, 25, 54-67. <https://doi.org/10.1006/ceps.1999.1020>
- Ryan, R. M. and Deci, E. L. (2000). Self-determination theory and the facilitation of intrinsic motivation, social development, and well-being. *American Psychologist*, 55, 68-78. <https://doi.org/10.1037/0003-066X.55.1.68>
- Savery, J. R. (2006). Overview Of PBL: Definition and Distinctions. *The Interdisciplinary Journal of Problem-based Learning*, 1(1), 57-75. <https://doi.org/10.7771/1541-5015.1002>
- Savery, J. R. and Duffy, T. M. (1995). Problem-based learning: An instructional model and its constructivist framework. *Educational Technology*, 35(5), 31-38.
- Shakirova, D. M. (2007). Technology for the shaping of college students' and upper-grade students' critical thinking. *Russian Education & Society*, 49(9), 42-52. <https://doi.org/10.2753/RES1060-9393490905>
- Soper, D. (2006-2013). Interaction [Computer software]. Available at: <https://www.danielsoper.com/Interaction/free.aspx>
- Stevens, T., Olivarez, A., Lan, W. Y. and Tallent-Runnels, M. K. (2004). Role of mathematics self-efficacy and motivation in mathematics performance across ethnicity. *The Journal of Educational Research*, 97(4), 208-221. <https://doi.org/10.3200/JOER.97.4.208-222>
- Subotnik, R. F., Tai, R. H. and Almarode, J. (2011). Study of the impact of selective SMT high schools: Reflections on learners gifted and motivated in science and mathematics. *The National Academies*. Available at: [http://sites.nationalacademies.org/cs/groups/dbassesite/documents/webpage/dbasse\\_072643.pdf](http://sites.nationalacademies.org/cs/groups/dbassesite/documents/webpage/dbasse_072643.pdf)
- Tekumru - Kisa, M., Stein, M. K. and Schunn, C. (2015). A framework for analyzing cognitive demand and content-practices integration: Task analysis guide in science. *Journal of Research in Science Teaching*, 52(5), 659-685. <https://doi.org/10.1002/tea.21208>
- U.S. Congress Joint Economic Committee. (2012). *STEM Education: Preparing for the Jobs of the Future*. Washington, DC: Author. Available at: [http://www.jec.senate.gov/public/index.cfm?a=Files.Serve&File\\_id=6aaa7e1f-9586-47be-82e7-326f47658320](http://www.jec.senate.gov/public/index.cfm?a=Files.Serve&File_id=6aaa7e1f-9586-47be-82e7-326f47658320)
- U.S. Department of Education. (2017). Reimagining the role of technology in education: 2017 National Education Technology Plan update. Available at: <https://tech.ed.gov/files/2017/01/NETP17.pdf>
- Unfried, A., Faber, M. and Wiebe, E. (2014). Gender and student attitudes toward science, technology, engineering, and mathematics. *The Friday Institute for Educational Innovation at North Carolina State University*. <https://doi.org/10.1037/t50151-000>
- Wang, M. C., Haertel, G. D. and Walberg, H. J. (1997) Learning influences, in: H. J. Walberg and G.D. Haertel (eds) *Psychology and Educational Practice* (Berkley, CA: McCuthan), pp. 199-211.
- Wang, X. (2013). Why students choose STEM majors: Motivation, high school learning, and postsecondary context of support. *American Educational Research Journal*, 50(5), 1081-1121. <https://doi.org/10.3102/0002831213488622>

- Weiner, B. (1985). An attributional theory of achievement motivation and emotion. *Psychological Review*, 92(4), 548-573. <https://doi.org/10.1037/0033-295X.92.4.548>
- Weis, L., Eisenhart, M., Cipollone, K., Stich, A. E., Nikischer, A. B., Hanson, J., Leibrandt, S. O., Allen, C. D. and Dominguez, R. (2015). In the guise of STEM education reform: Opportunity structures and outcomes in inclusive STEM-focused high schools. *American Educational Research Journal*, 52(6), 1024-1059. <https://doi.org/10.3102/0002831215604045>
- White House Office of Science and Technology Policy. (2015, March). *Progress Report On Coordinating Federal Science, Technology, Engineering, And Mathematics (STEM) Education*. Washington, DC. Available at: [https://obamawhitehouse.archives.gov/sites/default/files/microsites/ostp/stem\\_ed\\_budget\\_supplement\\_fy\\_16-march-2015.pdf](https://obamawhitehouse.archives.gov/sites/default/files/microsites/ostp/stem_ed_budget_supplement_fy_16-march-2015.pdf)
- Wigfield, A. and Eccles, J. S. (2000). Expectancy–value theory of achievement motivation. *Contemporary Educational Psychology*, 25(1), 68-81. <https://doi.org/10.1006/ceps.1999.1015>
- Wigfield, A. and Eccles, J. S. (2002). The development of competence beliefs, expectancies for success, and achievement values from childhood through adolescence. In A. Wigfield and J. S. Eccles (Eds.), *A Vol. in the Educational Psychology Series. Development of Achievement Motivation* (pp. 91-120). <https://doi.org/10.1016/B978-012750053-9/50006-1>
- Wu, J. Y., Hughes, J. N. and Kwok, O. M. (2010). Teacher–student relationship quality type in elementary grades: Effects on trajectories for achievement and engagement. *Journal of School Psychology*, 48(5), 357-387. <https://doi.org/10.1016/j.jsp.2010.06.004>



<http://www.lectitopublishing.nl>



<https://www.facebook.com/LectitoJournals/>



<https://twitter.com/lectito1>



<https://www.linkedin.com/in/lectito-journals-9a675010b/>

## Student Teachers' Use of Data Feedback for Improving their Teaching Skills in Science and Technology in Primary Education

Peter L. Bom <sup>1\*</sup>, Maaïke Koopman <sup>1</sup>, Douwe Bijwaard <sup>1</sup>

<sup>1</sup> Teacher Educator at the Ede Christian University of Applied Sciences and PhD Student at the Eindhoven School of Education of the Eindhoven University of Technology, NETHERLANDS

<sup>2</sup> Assistant Professor at the Eindhoven School of Education of the Eindhoven University of Technology, NETHERLANDS

<sup>3</sup> Professor of Professional Learning at the Eindhoven School of Education of the Eindhoven University of Technology, NETHERLANDS

\*Corresponding Author: [plbom@che.nl](mailto:plbom@che.nl)

**Citation:** Bom, P. L., Koopman, M. and Bijwaard, D. (2019). Student Teachers' Use of Data Feedback for Improving their Teaching Skills in Science and Technology in Primary Education. *European Journal of STEM Education*, 4(1), 09. <https://doi.org/10.20897/ejsteme/6285>

**Published:** November 16, 2019

### ABSTRACT

In this study, student teachers explored four data collection methods for data feedback to improve their teaching skills in Science and Technology [S&T]. The aim was to verify whether these methods were suitable for collecting data concerning their teaching skills during S&T activities in their internships. They analysed the collected data and drew conclusions about the quality and possible improvements of their teaching skills. Logbooks and focus group interviews were used to collect data regarding the suitability of the utilised data collection methods. The findings indicate that the questionnaires, interviews, and observations provided suitable data in some cases; however, this strongly depended on how the student teachers applied these data collection methods. The results provide insights into the problems student teachers encounter in collecting, analysing and interpreting data and how they can be supported therein. Furthermore, it appeared that student teachers need to possess sufficient knowledge and skills to utilise data collection methods, so that specific training in this field is required.

**Keywords:** data feedback, pedagogical skills, student teachers, inquiry-based science education, science and technology

### INTRODUCTION

Many primary school teachers in Europe, Australia and North America find it difficult to teach Science and Technology [S&T] (Appelton, 2006; Gillies and Nichols, 2014). They only teach S&T occasionally, which consequently can result in their pupils being less interested in S&T (Van Aalderen-Smeets, Walma van der Molen, and Asma, 2012). This is partly due to inadequate training during their teacher education (Avery, 2012). Alake-Tuenter (2014) urgently advises primary teacher education institutes to provide sufficient opportunities for their students to develop their pedagogical skills regarding S&T education and to support and mentor them during practice.

Several studies have shown that in-service teachers' S&T teaching skills improve when they repeatedly experiment with S&T teaching theory in practice and discuss their experiences in follow-up workshops (Gillies and Nichols, 2014; Smith, 2013). These studies also stress the importance of teachers obtaining ownership of their professional development during this learning process.

Teachers acquired this ownership when they had the opportunity to practice new teaching approaches and made decisions based on their own analyses of the problems they encountered in practice (Butler and Schnellert, 2012). To be able to correctly and systematically analyse their practice, teachers needed to build on reliable data that is representative of their teaching. Such data enabled them to make informed decisions and improve their teaching skills.

In this article, systematically collecting data for development of teachers' pedagogical skills is referred to as data feedback. Data feedback can increase the quality of teachers' decisions and stimulate continuous improvement (Fullan, 2001; Van Veen, Zwart, and Meirink, 2012). Van den Hurk, Houtveen, Van de Grift, and Cras (2014) tested data feedback with student teachers. Their findings show that student teachers improved their pedagogical skills by using researchers' feedback based on observations of their instruction quality. As a result, the student teachers were more successful in increasing their pupils' self-confidence and encouraging them to spend more time on their tasks. However, the data that drove the data feedback process in this study were collected by researchers. Studies in which student teachers themselves are responsible for collecting and analysing data for data feedback are scarce (Schnellert, Butler, and Higginson, 2008).

This study aims to identify which data collection methods generate suitable data for data feedback to aid the development of student teachers' pedagogical skills in stimulating pupils' attitude towards S&T. The specific focus on attitude is significant since pupils with a positive attitude towards S&T tended to be more engaged in and make more considerate choices regarding S&T topics as adults (Osborne, Simon, and Collins, 2003). Pupils with a positive attitude towards S&T did not only enjoy S&T activities, but were also eager to understand S&T subjects and to carry out S&T activities to satisfy their curiosity (Hillman, Zeeman, Tilburg, and List, 2016). Although studies that use data feedback to improve teachers' S&T teaching skills have been carried out before (Gerard, Spitulnik, and Linn, 2010; Smith, 2013), none of these studies had a specific focus on teaching skills in stimulating pupils' attitudes towards S&T. In this study, four different data collection methods were designed and tested by student teachers. This was a considerable challenge for them, as they had limited experience in collecting and analysing data and students were inexperienced in looking at, and learning from, classroom data. A data collection method is only suitable for data feedback when it enables student teachers to collect data that enables them to improve their teaching skills.

The main question of this study is: which data collection methods generate suitable data for data feedback to aid the development of student teachers' pedagogical skills in stimulating primary school pupils' positive attitude towards S&T? The related sub-questions are:

(1) how do student teachers use the data collection methods, (2) which strengths and weaknesses do student teachers experience while using the data collection methods, and (3) to what extent does analysing and interpreting the collected data aid student teachers in improving their pedagogical skills?

This study creates insight into how student teachers can develop their pedagogical skills to stimulate their pupils' attitude in a systematic manner. The results may contribute to providing student teachers with tools to allow them to assess their own development and to continue their professional development independently after completing teacher education.

## **THEORETICAL FRAMEWORK**

### **Pedagogical Skills**

Our modern society is increasingly influenced by S&T knowledge. As such it is important that future generations understand how they can use and build on this knowledge. Children [aged 10 -11] with a positive attitude towards S&T, seem to show more interest in S&T and select an S&T related profession as adults more often (Osborne, Simon, & Collins, 2003). Hence, primary teachers need to be aware of the fact that stimulating their pupils' attitude towards S&T needs explicit attention (Van Aalderen-Smeets et al., 2012). To this end, teacher education institutes need to prepare student teachers for this task by ensuring that they (1) master S&T knowledge, (2) have a positive attitude towards S&T and S&T teaching, (3) and possess sufficient pedagogical skills for S&T education. Alake-Tuenter (2014) showed, however, that Dutch teacher education institutes insufficiently meet these three objectives. Our study focuses on the third objective, the development of student teachers' pedagogical skills.

Several studies have shown that pupils' attitude towards S&T becomes more positive when S&T is taught according to the principles of Inquiry Based Science Education [IBSE] (Murphy, Murphy, and Kilfeather, 2011). IBSE is an approach to teaching and learning in which the key principle is that pupils develop their ideas about science and engineering topics by means of experimentation and interpretation of inquiry driven results. It is also important that pupils discuss their findings with each other and reflect on their inquiry process (Driver, Asoko, and Leach, 1994).



Often, IBSE activities are structured using the 5E Instruction Model, which is an internationally recognized instruction model comprehensively described by Bybee et al. (2006). This model includes the following phases: engage, explore, explain, elaborate, and evaluate. For example: in a 5E structured lesson on electrical circuits, the teacher takes apart a battery-operated bedside lamp and asks questions about the materials encountered during that process in the engage phase. In the exploration phase, pupils explore how the battery, wires and a bulb work and they try to light the bulb in small groups. In the explanation phase, the pupils discuss what they discovered during the exploration phase with the teacher. In the elaboration phase, pupils can investigate one of the questions that emerged during the explanation phase by conducting an experiment on electricity or by designing a product in which an electrical circuit is built. In the evaluation phase, the pupils present and discuss their findings and/or products.

To enable student teachers to stimulate pupils' attitude towards S&T through IBSE and the 5E Instruction Model, they need to acquire specific pedagogical skills. This study distinguishes two types of pedagogical skills, each having its own characteristics: pedagogical skills to support pupils' cognitive needs and pedagogical skills to support pupils' social needs (Driver et al., 1994; Hodgson and Pyle, 2010). Cognitive pedagogical skills are employed to foster pupils' S&T understanding during the 5E Instruction Model phases. Examples of these pedagogical skills are stimulating pupils' thinking by asking questions, and letting them experiment, observe, and reason (Bybee et al., 2006). The cognitive pedagogical skills intend to stimulate pupils towards a positive attitude for S&T by encouraging their interest in S&T subject matter and activities. Social pedagogical skills are employed to foster pupil wellbeing and enable pupils to express themselves during the phases of the 5E model (Driver et al., 1994). Although social pedagogical skills have a broader application beyond IBSE, this study addresses the social pedagogical skills within the context of the 5E model. Examples of these pedagogical skills are stimulating self-confidence to do 'hands-on' activities and involving all pupils in discussions (Hodgson and Pyle, 2010). The social pedagogical skills intend to stimulate pupils towards a positive attitude for S&T by encouraging pupils' confidence to address the S&T subject matter and activities according to their own preferences, and thus acquire affinity for S&T.

**Table 1** shows which pedagogical skills are required for each phase of the 5E Instruction Model. The skills mentioned in **Table 1** are derived and adapted from teacher instructions on how to apply the 5E Instruction Model listed by Bybee et al. (2006: 34) and from Goldston, Dantzler, Day, and Webb (2013), who developed an instrument to measure the quality of 5E modelled lesson plans.

**Table 1.** Pedagogical skills required for stimulating pupils' attitude towards S&T, per phase of the 5E instruction model

Phase in 5E-instruction model	Cognitive pedagogical skills:	Social pedagogical skills:
1. Engage	<ol style="list-style-type: none"> <li>collecting materials linked to pupils' everyday context</li> <li>eliciting students' prior knowledge (related to the lesson objectives)</li> <li>raising pupils' interest/motivation to learn</li> </ol>	<ol style="list-style-type: none"> <li>creating a social atmosphere in which pupils can express themselves freely</li> </ol>
2. Explore	<ol style="list-style-type: none"> <li>providing suitable and challenging materials</li> <li>presenting instructions clearly</li> <li>asking questions that evoke pupils' ideas and stimulate pupils to explore materials</li> </ol>	<ol style="list-style-type: none"> <li>encouraging pupils to bring questions forward</li> <li>stimulating self-confidence to do 'hands on' activities</li> </ol>
3. Explain	<ol style="list-style-type: none"> <li>asking questions that lead to development of concepts and skills (drawing upon the Explore activities or data collected during the Explore activities)</li> <li>leading an interactive discussion driven by divergent and convergent questions</li> </ol>	<ol style="list-style-type: none"> <li>involving all pupils into the discussion</li> </ol>
4. Elaborate	<ol style="list-style-type: none"> <li>providing sufficient and appropriate materials to enable pupils to conduct their experiment/design</li> <li>enabling pupils to test their concepts by means of their experiments or designs</li> <li>coaching and stimulating small-group discussions about the experiment/design</li> </ol>	<ol style="list-style-type: none"> <li>making a deliberate group-distribution considering differences between pupils</li> <li>facilitating shared ownership within the small groups</li> <li>facilitating pupils' collaboration</li> </ol>
5. Evaluate	<ol style="list-style-type: none"> <li>determining beforehand which kind of presentation is most suitable</li> <li>enabling pupils to evaluate their own experiment/design</li> </ol>	<ol style="list-style-type: none"> <li>making pupils feel proud of their experiment/design</li> </ol>
6. During all phases	<ol style="list-style-type: none"> <li>making connections with everyday contexts</li> <li>motivating pupils for S&amp;T subjects</li> </ol>	<ol style="list-style-type: none"> <li>creating situations in which justice is done to pupils' diversity</li> </ol>

## Data Feedback

In this study, data feedback was used to aid the development of student teachers' cognitive and social pedagogical skills in stimulating pupils' positive attitude towards S&T. Data feedback usually aims to improve teachers' instructional skills to foster pupils' cognitive development, and this is common practice in many schools in Europe and North America already (Carlson, Borman, and Robinson, 2011; Van Geel, Keuning, Visscher, and Fox, 2016). The data used for data feedback in those schools are, for example, assessment results and student questionnaire data (e.g. pupils' perceptions of the quality of their teachers' instruction; Schildkamp and Kuiper, 2010). To structure data feedback for the improvement of teachers' instructional skills an instructional change cycle was developed (Schnellert et al., 2008). This cycle contained the following steps: setting instructional goals, designing new instructional strategies, conducting new instructional practices, collecting and analysing data, and deciding which further actions to take. The instructional change cycle is intended to be carried out in small groups of collaborating teachers who run through a process of self-regulated learning by thoroughly looking into their own classroom data without interference by researchers. Although it is known that teachers' pedagogical skills improve when using this method (Butler and Schnellert, 2012), it is not common practice in primary teacher education institutes.

As our study focused on student teachers' skills related to stimulating pupils' attitude, the above-mentioned instructional change cycle was adapted: the first and second step of the instructional change cycle were merged to stress that the pedagogical goal and the designed IBSE activity form a single unit. Another change was the addition of a new step, namely, designing a data collection method [step 2]. This new step was necessary as student teachers in this study select a data collection method which they adapt or redesign in such a way as to be able to collect data reflecting the development of the specific pedagogical skills - aimed at stimulating pupils' attitude towards S&T. The step of 'collecting data' was relocated from the fourth step [instructional change cycle] to the third step as this occurred either simultaneously or immediately after the IBSE activity. Consequently, the fourth step consisted of analysing the collected data. Finally, the fifth step included a conclusion of which further steps to take and a self-reflection regarding student teachers' development of their pedagogical skills during the completion of the data feedback cycle (evaluation). The data feedback cycle as displayed in **Figure 1** was used in this study.

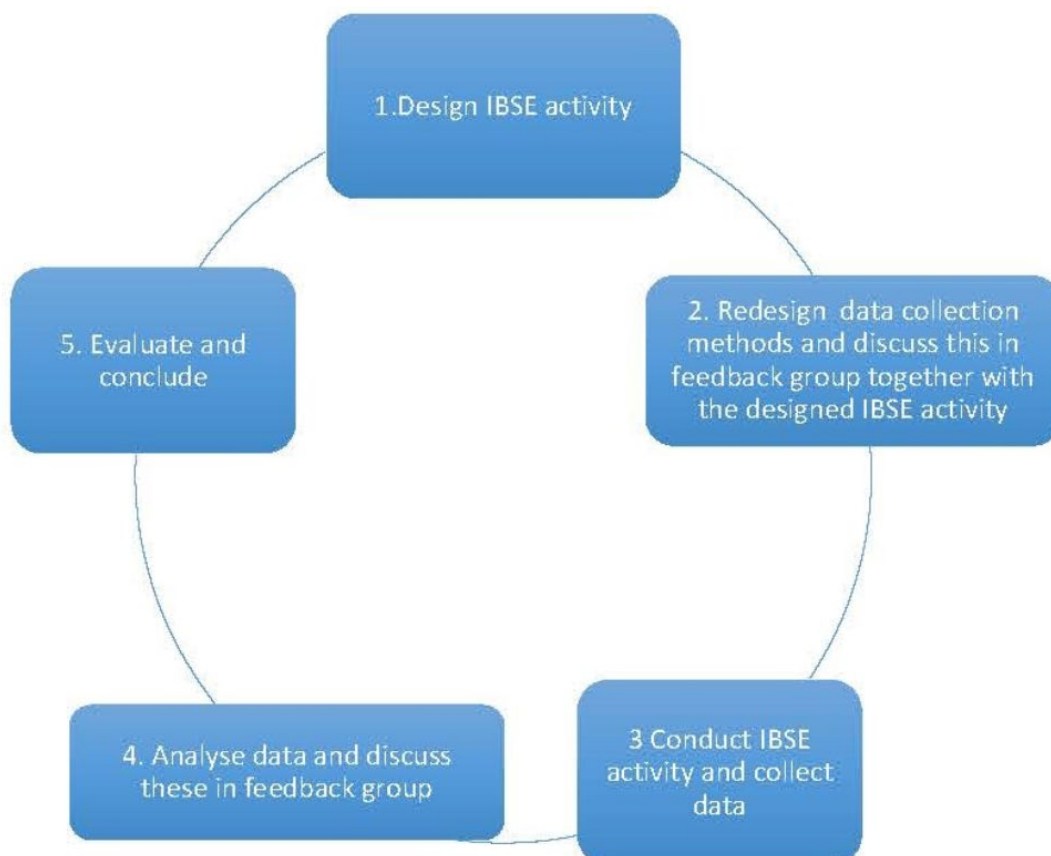

**Figure 1.** Data feedback cycle for development of IBSE teaching skills

## METHOD

### Context and Participants

The study was carried out at an institute for primary teacher education in the Netherlands. The participants (n=19) were student teachers in the penultimate year of their bachelor's study who attended a semester programme in which IBSE was the main theme. All participants were between 19 and 23 years old and had more than two years of internship teaching experience.

The participating student teachers completed two data feedback cycles ([Figure 1](#)), each containing a practical part conducted during their internship at primary schools. These data feedback cycles were the central activities during the semester programme. The participants were trained and directed in using the data feedback cycles by the teacher educator. Aside from the data feedback cycles, the semester programme also consisted of several theoretical and applied lectures on IBSE, an excursion to a science museum, and excursions to primary schools where IBSE activities were daily practice.

Data were collected on two different levels in this study. Firstly, by the participating student teachers, who utilised tools to collect data for the use of data feedback to develop their pedagogical skills in stimulating pupils' positive attitude towards S&T. These tools will be termed as data collection methods from this point onwards. Secondly, data were also collected by the researcher in order to analyse whether, and how, the data collection methods utilised by student teachers generated suitable data for feedback to aid the development of their pedagogical skills in stimulating pupils' attitudes towards S&T. The tools used by the researcher will be called instruments.

### Design and Procedure

The participating student teachers completed the data feedback cycle ([Figure 1](#)) twice over a period of 14 weeks. We opted for two data feedback cycles for two reasons. Firstly, to allow participants to practice the data feedback process during the first cycle and apply improvements in the second cycle. Secondly, to identify participants' ability to apply the pedagogical skills learned in the first cycle, in the second cycle. Each data feedback cycle lasted seven weeks ([Table 3](#)).

A data feedback cycle consisted of five steps ([Figure 1](#)):

1) The participants started by determining which pedagogical skills ([Table 1](#)) they had not yet fully mastered. Following this, they selected one or two skills and designed an IBSE activity that would provide them the opportunity to develop this skill. It was opted to let the participants choose their own pedagogical skills in order to allow them to have ownership of their development; the skills chosen by each of the participants are listed in [Table 2](#). The pedagogical skills displayed in [Table 1](#) indicate which skills are most characteristic for each 5E model phase. The skills are deliberately non-specific to provide (student) teachers the opportunity to individualise these skills in line with their personal development.

2) The participants were confronted with four types of data collection methods selected by the researcher: classroom observations, group interviews, pupils' drawings, and questionnaires. These four methods were introduced in two lectures outlining how to use these methods for collecting valid data. These lectures pertained to classroom research in general and to collecting data about participants' own pedagogical skills. Following this, each participant chose two out of the four data collection methods and (re)designed the methods to better fit these to the pedagogical skills they strived to master. Once again it was opted to let the participants choose (this time the data collection methods) to strengthen participant ownership; the data collection methods that each of the participants chose are displayed in [Table 2](#). To facilitate participants during the process of (re)designing the chosen method, information from two Dutch textbooks on research methods for doing educational research (Baarda, 2010; Onstenk, Kallenberg, Koster, and Scheepsmma, 2011) were available. In addition, participants were encouraged to consult articles or books specifically dealing with pupils' attitude towards S&T in which sample observation tools (Laevers & Peeters, 1994), interview questions (Fitzgerald, Dawson, and Hackling, 2013), children's drawings (Murphy, Varley, and Veale, 2012), or questionnaire items were listed. The second step ended by discussing the IBSE activities designed in step 1 and the redesigned data collection methods within the feedback groups. Specific feedback on the designed data collection method was given by the teacher educator and peers during these meetings to allow participants to collect valid data.

3) The participants conducted the designed IBSE activity in practice and collected data using their redesigned data collection methods.

4) The participants analysed and interpreted the collected data in order to find out whether and how they had succeeded in improving the pedagogical skills they selected. The collected data, the analyses, and the interpretations were then discussed within the feedback groups. Once again, for each feedback group there was a teacher educator present for consultation, this time focusing on analysing and interpreting the collected data.

5) The participants completed the data feedback cycle by evaluating the data feedback process and by drawing conclusions concerning their skills' development. Following this, all participants repeated the data feedback cycle. In order to create a diverse and thorough impression of how a data collection method could be utilised, each participant piloted two different types of data collection methods and used those methods in both data feedback cycles.

**Table 2.** The data collection methods and the pedagogical skills that student teachers chose

Student teacher	Chosen data collection methods	Chosen pedagogical skills*
Miranda	observation, interview	2.2, 4.6
Yolanda	observation, drawing	6.2
Max	observation, drawing	4.2, 6.2
Margaret	observation, questionnaire	2.4, 4.2
Erin	observation, questionnaire	3.2, 3.3
Cynthia	observation, questionnaire	2.4, 4.2
Nadia	interview, drawing	4.2, 6.2
Lucy	interview, drawing	4.2, 6.2
Ellie	interview, drawing	3.2, 6.2
Tobias	interview, questionnaire	4.4, 6.2
Isabelle	interview, questionnaire	1.2, 4.2
Liam	interview, questionnaire	4.4, 5.3
Claudia	interview, questionnaire	2.5, 3.2
Jim	interview, questionnaire	4.4, 4.5
Alice	interview, questionnaire	2.3, 4.5
Mark	interview, questionnaire	4.2
Barry	Interview, questionnaire	2.5, 4.5
Jack	interview, questionnaire	2.5, 4.6
Laura	drawing, questionnaire	4.1, 6.2

\* The numbers in this column correspond to the numbers of the pedagogical skills in [Table 1](#) [For example 4.2; 4 represents the phase of the 5E model and 2 represents the number of pedagogical skills within that phase]

**Table 3.** Timeframe of participants' activities during the data feedback cycles

Week	Participants' activity: (data feedback step between brackets)
1 & 8	- selecting pedagogical skill(s) for data feedback (step 1) - designing IBSE activity (step 1) - forming feedback groups of 5 participants each (only in the 1 <sup>st</sup> week)
2 & 9	- discussing designed IBSE activity in feedback group (step 1) - selecting and redesigning data collection method (step 2)
3 & 10	- discussing redesigned data collection method in feedback group (step 2)
4 & 11	- conducting IBSE activity and collecting data (step 3)
5 & 12	- analysing and interpreting collected data (step 4)
6 & 13	- discussing analyses and interpretations in feedback group (step 5)
7 & 14	- reflecting on the data feedback process and concluding whether and if so, how their pedagogical skills can be improved (step 5)
Week	Participants' activity: (data feedback step between brackets)
1 & 8	- selecting pedagogical skill(s) for data feedback (step 1) - designing IBSE activity (step 1) - forming feedback groups of 5 participants each (only in the 1 <sup>st</sup> week)
2 & 9	- discussing designed IBSE activity in feedback group (step 1) - selecting and redesigning data collection method (step 2)
3 & 10	- discussing redesigned data collection method in feedback group (step 2)
4 & 11	- conducting IBSE activity in practice and collecting data (step 3)
5 & 12	- analysing and interpreting collected data (step 4)
6 & 13	- discussing analyses and interpretations in feedback group (step 5)
7 & 14	- reflecting on the data feedback process and concluding whether and if so, how their pedagogical skills can be improved (step 5)

## Instruments

Two instruments, logbooks and focus group interviews, were used to collect data reflecting whether and how the data collection methods participants used generated suitable data for data feedback.

### *Logbooks*

The participants reported on how they had performed and experienced each step of the data feedback cycle in an individual logbook. The logbook was intended to reveal how they collected, analysed, and interpreted data. The logbook was aimed to provide insight into how the participants experienced the particular data collection methods they used (Ketelaar, Koopman, Den Brok, Beijaard, and Boshuizen, 2014).

During or after conducting a data feedback cycle step the participants addressed the following questions in their logbooks:

- Step 1: What pedagogical skill(s) do you want to improve? Which S&T-activity are you going to conduct?
- Step 2: Which data collection methods are you going to utilise? What data do you intend to collect?
- Step 3: Which data were collected and what were your experiences during data collection? What strengths and weaknesses did you encounter in collecting your data?
- Step 4: How did you analyse and interpret the collected data? How did your feedback group react to your analyses and interpretations?
- Step 5: Did the reflection on the collected data change your view on your own pedagogical skill(s), and if so how? In hindsight, how did you experience working with the utilised data collection methods?

Once the first feedback cycle had been completed, the participants received feedback from the teacher educators on how they utilised the data collection method based on what they reported in their logbook. During the second data feedback cycle, participants answered the same questions in their logbook.

### *Focus group interviews*

After having finished their logbook for the second data feedback cycle, four focus group interviews were conducted with the student teachers (one per data collection method). The aim of these interviews was to gain in-depth insight into how they collected, analysed, and interpreted the data for developing their pedagogical skills (Krueger and Casey, 2015).

The participants' experiences were examined by interviewing groups of six randomly selected participants that utilised the same data collection method. It was decided to select six participants per interview as this would allow the emergence of different experiences and opinions while still being manageable enough to ensure that all participants had ample opportunity to share their experiences. In each focus group interview the following main questions were addressed: (1) how were data collected, (2) how were data analysed, and (3) did the collected data generate suitable information that could be utilised to improve participants' pedagogical skills for IBSE? In the interviews, the participants' experiences and underlying motives for making decisions concerning the application of the method were examined. Once a main question was posed, the participants had the opportunity both to answer the question and to react until no new information was mentioned. The researcher, who was the interviewer, kept the discussions within the boundaries of the subject and also encouraged the discussion without leading the participants to specific opinions (Hilby, Stripling, and Stephens, 2014). Each interview lasted about 60 minutes and was audio-taped and transcribed verbatim.

## Data Analysis

The data gathered by means of the logbooks and the focus group interviews were analysed in two phases. In the first phase, all data were thoroughly read and divided into fragments. The resulting fragments were then labelled using ATLAS.ti 7.5; a total of 234 fragments were labelled. Some labels addressed which data collection method the fragment pertained to. Some of the fragments addressed a weakness or strength of a data collection method. In order to gain insight into the suitability of a method, these fragments were labelled as such. An example fragment from a focus group interview is the following phrase: "I asked the pupils to write down what their drawing represented; if I had only looked at the drawings at home, I would not have known what they represented". This fragment regarding the data collection method drawings, indicates how the participant deployed this method and that the participant was unable to interpret the drawing without a written explanation. Thus, this fragment has been labelled as 'drawings' and as 'weakness'. In addition to labels regarding methods and strengths and weaknesses, labels were assigned to fragments indicating participants' actions to improve the pedagogical skills they chose and their reflection on that actions. The following fragment from one of the logbooks illustrates how this part of the labelling was performed. "On the recording I saw that, during the discussion, the pupils were distracted by all the materials in front of them. Next time I will hand out the materials after I have finished the discussion to allow the pupils to have a better focus on it". This fragment has been labelled as 'observation' [given

that this was the data collection method used] and as 'involving all pupils into the discussion' [5E model skill 3.2, given that this was the pedagogical skill the participant aimed at].

During the second phase, the labelled fragments were placed in a matrix. Per data collection method, labelled fragments were linked to the following topics: (1) how was the data collection method performed by the participants, (2) the strengths and weaknesses of the data collection methods participants experienced, (3) whether the collected data reflected how participants mastered the pedagogical skills aimed at and to what extent analysing and interpreting the collected data aided participants to improve these skills.

An audit procedure was conducted by another researcher to check the transparency and accuracy of the labelling process, as well as the justifiability and acceptability of the analyses. This audit was carried out according to the stages presented by Akkerman, Admiraal, Brekelmans, and Oost (2008). The auditor considered the assignment of the labels to the fragments to be justifiable. The manner in which the data were analysed and matrixed was found to be transparent and consistent with the raw data. The audit report can be retrieved by contacting the first author.

## RESULTS

In this section the results will be displayed per data collection method.

### Data Collection Method: Observation

The six participants that chose the data collection method observation utilised two different approaches of observing their pedagogical skills: (1) with the aid of an observation instrument called the Leuven involvement scale (used by 2 participants) and (2) with the aid of (partly) self-designed observation forms (used by 4 participants). The results of those two approaches are displayed separately below as they differ in methodology and findings. Each of these observation methods generated data pertaining to a specific pedagogical skill.

#### *Performance of the data collection method - Leuven involvement scale*

The Leuven involvement scale (LBS-L; Laevers and Peeters, 1994) is a widely used classroom observation instrument enabling observers to determine the extent of pupils' (7-12 years old) involvement in the classroom; LBS-L was one of the sample observation tools in the semester programme. With LBS-L, the perceived behaviour of pupils can be graded on a scale of 1-5 (1= low involvement, 5= high involvement), and for scores 4 and 5 it can be ascertained whether pupils are sham involved (i.e. pupils show external signs of involvement such as wobbling on the chair or biting nails) or truly involved. Sham involvement is indicated by a [ ' ] behind the score. The participants who collected their data with the aid of the LBS-L video-recorded their IBSE activity. Based on this video-recording, participants determined their pupils' involvement using the LBS-L score list. Following this, they observed the video recordings again, this time to understand the relation between their pedagogical skills and the perceived pupil behaviour.

#### *Strengths and weaknesses - Leuven involvement scale*

The participants indicated that LBS-L is only suitable for collecting data regarding the pedagogical skill 'involving all pupils into the educational discussion' [3.2]. Furthermore, they mentioned that LBS-L requires rather detailed footage which they considered as a weakness as video recording classroom situations was not permitted in all schools.

#### *Relation between data and pedagogical skills - Leuven involvement scale*

Both participants were able to collect data which reflected how they mastered the pedagogical skill 'involving all pupils into the discussion'. In her logbook, Miranda reported having monitored a pupil involvement of 3 [LBS-L scale, moderate score] and added: "The pupils looked around and were distracted by all the materials in front of them during the educational discussion". Miranda concluded that it would be better to remove the materials before starting the educational discussion. Erin expressed doubts regarding the reliability of LBS-L in some cases: "one of the pupils has ADHD and therefore he wobbled a lot, this had to be marked as sham involvement while he was really involved."

The participant students, though, did not find that LBS-L aided them in improving their pedagogical skills. Miranda noted that despite the realistic impression of pupils' involvement provided by the LBS-L, it remained unclear how to improve this. This was confirmed by Erin in her logbook after she monitored a pupil involvement of 3 [LBS-L scale] during the educational discussion: "I still have no idea how I can improve my pupils' involvement." In order to improve their pedagogical skills adequately, participants needed to know the motives



behind pupils' perceived behaviour. Miranda indicated pupils' motives were more visible on video during the Elaborate phase because pupils express themselves more during this phase.

### ***Performance of the data collection method - [partly] Self-designed observation form***

Participants who were not allowed to video their pupils because of the primary school's privacy rules, used an observation form that was completed by their supervising in-service teacher [mentor] while the participant conducted the IBSE activity. Three of those participants designed their own observation form. They formulated questions that focused on pupils' behaviour, such as: is the pupil actively involved in the activity and how do pupils collaborate? The mentor had the opportunity to score these questions using a scale of 1-5 [1= low involvement/little collaboration, 5= high involvement/high degree of collaboration]. The fourth participant, Margaret, utilised an existing [and tested] observation form during her first IBSE activity (SLO, 2017), on which her mentor noted observations regarding her activities during each phase of the 5E Model. However, the data collected with the guidelines on that observation form did not reflect whether Margaret mastered her pedagogical skills, since it focused on her activities and not on the pupils' response to Margaret's activities. The form contained questions such as: how does the teacher deal with individual differences between pupils and how does the teacher challenge pupils? These questions prompted Margaret's mentor to describe only her actions and not her pupils' reaction even though Margaret also needed such data. In the second data feedback cycle she adapted the observation form to gather information on the pupils' reactions and informed her mentor to focus primarily on the impact of her actions on the pupils' behaviour.

### ***Strengths and weaknesses - [partly] Self-designed observation form***

The only strength mentioned by the participants was that the observation forms created opportunities for the mentors to encourage student teachers and to provide practical advice. Margaret noted "My mentor's remarks on the observation form encouraged me to continue." The participants mentioned two weaknesses. Firstly, only a few pupils could be monitored by the mentor simultaneously resulting in a limited amount of obtained data. Secondly, the quality of the feedback depended on the mentors' expertise. The latter was expressed by participant Cynthia: "I depend on what the mentor wrote down. If I had had footage, I could have checked whether it was true and what the mentor intended."

### ***Relation between data and pedagogical skills - [partly] Self-designed observation form***

The participants who developed their own observation form experienced difficulties in formulating clear observable actions which could be used to improve their skills. Margaret, however, demonstrated how the collected data aided her in improving the pedagogical skills that enabled pupils to test their concepts by conducting their own experiment or design [4.2]. During the IBSE-activity, her mentor had recorded Margaret's actions as well as her pupils' responses to those actions on the observation she redesigned. This is illustrated by Margaret in her logbook:

My mentor wrote on the observation form: "A group of pupils wanted to test their designed self-running toy car in the test zone. It did not run well at all. Margaret observed the situation quietly and when the children looked at her she said: 'Maybe weight has something to do with it...' The children look at each other and said: 'Of course.... we made it far too heavy...' and went on redesigning." This was what I wanted to achieve. To enable pupils to test their concepts during their own design process by coaching.

Through the confirmation of having mastered the chosen pedagogical skill, Margaret knew she could strive to develop other pedagogical skills she did not yet master. In conclusion, observations [with the aid of LBS-L or other observation forms] are suitable for data feedback provided that the student teachers' actions and pupils' reactions are both monitored. However, this data collection method provided only limited aid in improving the pedagogical skills because the underlying motives of pupils' behaviour remain undetected.

## **Data Collection Method: Interview**

### ***Performance of the data collection method***

The data collection method interview was performed by 13 participants who all conducted semi-structured group interviews with groups of 2 to 4 pupils after the IBSE activity. The interview questions were prepared in advance and were aimed at specific pedagogic skills selected by the participant. For example, participant Jack intended to collect data regarding the pedagogical skill 'stimulating self-confidence to do hands-on activities' [2.5]. Thus, Jack prepared the question "did you think it was difficult to build the plane yourself?" to verify how confident

the pupils were during the hands-on activity. The interviews were recorded, transcribed and analyzed by the participants.

### ***Strengths and weaknesses***

The strength of the interview method appeared to be its suitability for collecting data to aid the improvement of the participants' pedagogical skills since these data directly show how the pupils experience their actions. This was illustrated by participant Isabelle in her logbook in the following interview fragment with two pupils Luke and Michael. "Isabelle: 'Can you tell me, what did you think of the lesson?' Michael: 'I liked it, but..' Isabelle: 'Yes..' Michael: 'How shall I put it? We didn't have enough time, we had to build too fast.' Luke: '..and we had a lot more to make.'" At the same time, participants experienced the following weaknesses: [a] finding a suitable time and place to conduct the interviews was sometimes difficult, [b] pupils sometimes felt uncomfortable when being interviewed, and [c] the participants struggled to formulate adequate follow-up questions. Claudia explained during the focus group interview "I expected the pupils to give better answers" and she did not know whether this was due to her questions or because the pupils felt uncomfortable with the situation. Barry remarked that an interview quickly becomes a formal affair resulting in pupils giving short factual answers.

### ***Relation between data and pedagogical skills***

Four participants succeeded in collecting data reflecting how they mastered the chosen pedagogical skill and all these participants collected data on how they mastered the pedagogical skill to enable pupils to test their concepts by conducting their own experiment or design [4.2]. Participants Tobias and Isabelle illustrated how the data they collected aided them to improve this pedagogical skill in their logbooks.

After the first IBSE activity, Tobias noted:

When I asked the pupils what they thought of the IBSE activity they reacted as follows: 'We are not used to thinking about the first step ourselves. The instruction was only: make something that moves with cogs, the rest we had to come up with by ourselves. This was too difficult for us.'

In response Tobias showed an open and accessible attitude by saying: "Good of you to tell me this" and then asked the in-depth question: "what would have helped you?" His pupils then explained that they needed clear instructions during the elaborate phase. Tobias concluded he mastered the chosen pedagogical skill insufficiently since he had provided insufficient support to enable his pupils to test their concepts. For this reason, he sought to provide this support during his follow-up IBSE activity. In the interview that followed, his pupils reported: "the goal and instructions were clear. You explained what the point was. This made trying it out more fun. We wanted to really try it out ourselves." Tobias concluded he had to consider carefully in advance which amount of self-regulation would stimulate the pupils during the elaborate phase.

Isabelle described that she had her pupils design a toy car that had to ride down a slope on completion. The point was to let it drive as far as possible from the slope. After interviewing her pupils, Isabelle noted:

At first the pupils were not reacting positively, they clearly indicated that they did not have enough time to test and adjust their designed car. As the interview progressed, the pupils became increasingly positive and I found out why the interview had started negative. The activity was fully in line with their interest and therefore they wanted more time to adjust their design.

Isabelle had asked her pupils the in-depth question: "you needed more time to improve your car, but what did you want to do?" In response her pupils told her in detail how they wanted to improve their car. This response aided Isabelle in understanding that her pupils would not only have been more motivated but would also have learned more if they had been given more time.

Most participants [9], however, failed to collect data reflecting how they mastered their chosen pedagogical skill as they did not ask in-depth questions.

In conclusion, student teachers' ability to collect data specific enough to indicate how they mastered their targeted pedagogical skill was largely dependent on their open and accessible attitude during the interviews and their persistence in asking in-depth questions in order to find helpful clues. It seemed essential to encourage pupils to express themselves and to regularly summarize what pupils said in order to avoid miscommunication. In contrast to the other students, Isabelle and Tobias were able to do so and considered their interview data highly suitable.

## Data Collection Method: Drawings

### *Performance of the data collection method*

All six participants that performed the data collection method drawings, chose to improve their pedagogical skill ‘motivating pupils for S&T subjects’ [6.2]. Thus, they had asked their pupils to make pre and post lesson drawings of themselves during an IBSE activity showing how motivated they were to conduct IBSE activities. Next, the participants compared the pre and post lesson drawings and drew conclusions. Four of the participants asked their pupils to write down what they had drawn, anticipating that some of the drawings might not be easily interpreted. This was illustrated in the focus group interview by participant Ellie:

I asked the pupils to write down what their drawing represented; if I had only looked at the drawings at home, I would not have known what they represented.

Ellie had her pupils draw their faces showing their emotions regarding the activity that caused the drawn emotion (Figure 2). The other participants had not explicitly instructed their students to draw their emotion in a separate drawing. However, they indicated that the emotion in their pupils’ drawing was often clearly visible.

### *Strengths and weaknesses*

The strengths of the method drawings appeared to be: pupils enjoyed making drawings, it required little preparation on the part of the participants and many of the drawing provided a good impression of the pupils’ motivation for the IBSE-activity. The latter was illustrated by Ellie who had given her pupils a basin partly filled with water and challenged them to build a dike that holds all the water to one half of the basin. Ellie discussed this in the focus group interview, stating:

Things really did not go well at some points and the dikes collapsed quite often. Still, the drawings showed me that they were having fun during this activity [as in Figure 2, many of her pupils drew drawings depicting happy faces]. Then, I think, I have done a good job.

On the other hand, the main weakness mentioned by the participants is that the drawings were often unclear and not specific enough for the participants to know how to improve their pedagogical skills.



**Figure 2.** One pupils’ drawings showing emotion during the IBSE activity [Note: The statement above the drawing can be translated as “very much fun”]

### *Relation between data and pedagogical skills*

The drawings reflected how the pupils had experienced the IBSE activity emotionally, which allowed the participant to have a rough understanding of how they mastered the pedagogical skills. However, these data were insufficiently specific to aid in improving their skills. In the focus group interview, participant Laura reported the following on her pupils’ drawings “they drew exactly what they had done in class, I had no information regarding my actions.” On the other hand, Lucy mentioned she had succeeded in understanding how the pupils had experienced the IBSE activity emotionally which allowed her to know whether she had succeeded in her IBSE activity.

In conclusion, the participants indicated that pupils’ drawing of themselves during the IBSE activity provided only basic information regarding pupils’ attitude; they were unable to improve specific pedagogical skills based on these drawings.

## Data Collection Method: Questionnaire

### *Performance of the data collection method*

The data collection method questionnaire was used by 13 participants. Since the participants discussed their questionnaire designs in the feedback groups, they would use each other's questions whenever possible. The final questionnaires were different as each participant intended to collect data regarding a different pedagogical skill. The length of the questionnaires varied from eight to 15 questions. The type of questions also varied across the questionnaires. Some participants used items combined with a 4/5-point Likert scale while others selected multiple choice questions or ranking questions or a mix of all those types of questions. The questions were thus mainly closed questions. Participants presented the questionnaires to their pupils before and after the IBSE activity. Afterwards, they put the collected data in graphs and compared the pre and post lesson questionnaire scores.

### *Strengths and weaknesses*

In general, the participants regarded the data collection method questionnaire as positive. The reported strengths were that the data could be collected easily and quickly, and analysing the data and drawing conclusions was considered to be relatively convenient. Jack expressed this argument in his logbook as follows: "With this method, I had all the data swiftly collected and organized." Besides the strengths, the participants indicated the following weaknesses: when (a) there were a high number of questionnaires to fill out during a given time frame, (b) the questionnaires contained too many questions, and (c) the questionnaires were administered at the end of the day, pupils did not fill out the questionnaires carefully.

### *Relation between data and pedagogical skills*

Most participants indicated that the collected data reflected how they mastered the pedagogical skill 'motivating pupils for S&T subjects' [6.2] in their logbooks. To that end, they formulated questions such as "would you like to do IBSE activities more often?" and "would you like to learn more about S&T topics?". In Tobias' case 15 pupils out of 20 responded positively to the first question prior to his first IBSE activity. After the activity only 10 of his pupils responded positively to the same question. Thus, Tobias concluded that he had to improve his pedagogical skills.

While six participants concluded they mastered their chosen pedagogical skills insufficiently, none of them was able to identify how to improve their skills. Therefore, in the focus group interview, the participants agreed that it is necessary to collect additional data with other methods. Alice made the following point:

In the questionnaire a pupil can indicate 'I enjoyed the lesson' but I had no idea why he indicated that, or which of my actions was responsible for that. But you can use the questionnaire during your interview and ask pupils for clarification.

Yet, Tobias noted in his logbook:

I assumed that my pupils would appreciate it when I provided them with ample opportunity for self-regulation [in the first IBSE activity]. Anyway, this did not work. Results from the questionnaire [see above] showed that the pupils did not appreciate this. From the interviews, I learned that the pupils benefit more from structured teaching. Within that structure, they want to have opportunities for self-regulation [see the section *Data Collection Method: Interview*].

In conclusion, the participants agreed that the data from questionnaires and interviews seemed to complement each other. The questionnaires provided participants with a general idea of the extent to which they mastered the pedagogical skills, and the interviews allowed them to acquire data that enabled them to improve their skills.

## DISCUSSION

### **Main Findings**

Regarding the first research question pertaining to how student teachers used the data collection methods, the findings indicate that participants were insufficiently prepared for designing and using data collection methods since they had significant difficulties in this respect. For example, the participants struggled to design suitable observation forms and to ask follow-up interview questions to obtain useful detailed information. Only a few participants used data collection methods in such a way that suitable data were collected.

The second research question concerns the strengths and weaknesses participants experienced while using the data collection methods. The participants experienced both; the main strengths they encountered were: a) observation through video footage of classroom situations proved to be a suitable method for determining pupil involvement b) observation forms filled in by a mentor sometimes strengthened student teachers' development. c) interviews provided specific pupil statements which aided the participants to understand how pupils experienced their actions, and d) the questionnaires provided the participants with an easy overview on how their pupils had experienced the IBSE activity. The main weaknesses that emerged were: a) in some schools video recording classroom situations was not permitted, b) finding the right time and place to interview pupils was sometimes difficult, and c) problems with poorly completed questionnaires due to bad timing and having too many questions in the questionnaires. The drawings provided a general impression of pupils' attitude, however, the participants were unable to find clues for improving their pedagogical skills within such data. Hence, drawings do not seem suitable for data feedback.

The third research question pertains to the extent to which analysing and interpreting the collected data aided student teachers in improving their pedagogical skills. However, due to the participants' lack of research skills, this study yielded little suitable data on this research question. In some cases, however, the participants collected data that aided them to understand how to improve their skills. Participants using interviews in an effective manner were characterised by having an open and accessible attitude towards their pupils during the interviews and being persistent in asking in-depth questions to unearth helpful clues. Participants who met those two conditions collected suitable data, which enabled them to effectively improve their pedagogical skills. Some participants found that the data collected through questionnaires were suitable as a starting point for the interview questions. Data collected with observations might be used in a similar manner.

Within the semester programme the participants completed two data feedback cycles instead of one in order to enable the participants to apply lessons learned from the first cycle in the second cycle. This functioned for some participants; for example, in the second cycle Margaret and Isabelle made clear improvements to their data-collection method and Tobias to his pedagogical skills.

### Implications for Practice

Most participants had collected data that was insufficiently suited to improving a targeted pedagogical skill. The reason for this might be that they did not have a clear personal goal in view, despite this being a requirement for (re)designing a suitable data collection method (Schnellert et al., 2008). The participants started each data feedback cycle by setting their goals and selecting a pedagogical skill they intended to improve (**Table 1**), but most of them were unable to (re)design a data collection method to collect suitable data that related to both the specific characteristics of the chosen skill and the personal emphasis of a participant in terms of what he/she wanted to learn in particular related to that skill. Margaret was one of the participants with a clear personal goal. She showed an understanding of the specific characteristics of the pedagogical skill she had chosen, and these characteristics were visible in the data she collected. The goal she had from the outset enabled her to collect suitable data during the second data feedback cycle. To allow student teachers to tailor the pedagogical skills [**Table 1**] to specific personal goals, they are required to have a clear view of their final result: what should the skill look like in my practice once I have mastered it [observations] or what should my pupils say after a lesson if I mastered the skill [questionnaire and interview]? By encouraging student teachers to reflect on such questions in step 1 [**Figure 1**], they will acquire a more concrete notion on what they want to achieve in their own practice related to both the 5E skills and their personal context. If student teachers consider the chosen pedagogical skill as part of their professional development as prospective teachers it is likely that, like Tobias and Margaret, the preparedness of other student teachers to take ownership of those pedagogical skills' development will increase.

Another explanation for having only a few participants successfully collect suitable data to improve their pedagogical skills lies in their lack of research skills. Therefore, data feedback step 2 [(re)design a data collection method] and step 3 [collecting data] require extension with detailed instructions and discussions on how to design and perform the relevant data collection methods, illustrated, for example, by good and bad practices. This should enable student teachers to (re)design reliable and valid data collection methods and help them in being sufficiently equipped to carry out these methods.

### Limitations and Suggestions for Further Research

This exploratory study somewhat underexposed how student teachers analysed and interpreted their collected data. But, once student teachers have collected valid data, they need to be enabled to analyse and interpret those data in order to take well-informed decisions on how to improve their pedagogical skills. This aspect deserves explicit attention in follow-up studies on data feedback. In general, this study underestimated the complexity of having student teachers collect data that was aimed at helping them improve their pedagogical skills. Nevertheless,

the findings showed how student teachers collect and interpret data, which problems they encountered in doing so, and how some of them overcame these problems. While this was only a small-scale study limited to the context of primary teacher education, we expect that these insights allow us to optimise (student) teachers' education programme in which data feedback has a central role. The key components worth considering for the optimisation of such a programme appear to be: a) encouraging (student) teachers to set specific and personal goals, b) educating (student) teachers in collecting, analysing and interpreting valid data, and c) teacher educators' enacting a role model in which they explicitly support (student) teachers in collecting, analysing and interpreting data for data feedback. Follow-up research will focus on these three factors in an attempt to improve (student) teachers' education in teaching S&T.

## CONCLUSION

This study aimed to design and test data collection methods on their suitability to generate data for data feedback to aid the development of student primary teachers' pedagogical skills for IBSE. Our findings suggested that such suitable data can be collected with three of the four data collection methods we tested, namely observations, interviews, and questionnaires. However, the findings also showed that most of the participating student teachers struggled in (re)designing and performing data collection methods, and thus, were unable to collect suitable data. To improve this, specific and profound curriculum adaptations are required.

Although there are only a few of them, our results illustrate some good practices. These good practices suggest that, given that certain conditions related to setting specific and personal goals and collecting valid data are met, student teachers will be able to use data feedback to develop their S&T teaching skills. These practices indicate that data feedback has the potential to aid student teachers in developing their pedagogical skills in stimulating their pupils' attitude towards S&T. In view of this, it is worthwhile to further investigate learning how to use data feedback in teacher education.

## ACKNOWLEDGEMENT

This research was funded by the *Nederlandse Organisatie voor Wetenschappelijk Onderzoek* [NWO; The Netherlands Organisation for Scientific Research].

## REFERENCES

- Akkerman, S., Admiraal, W., Brekelmans, M. and Oost, H. (2008). Auditing Quality of Research in Social Sciences. *Quality & Quantity TA*, 42(2), 257-274.
- Alake-Tuenter, E. (2014). *Inquiry-based science teaching competence of pre-service primary teachers*. Wageningen University, Wageningen.
- Appelton, K. (2006). Science pedagogical content knowledge and elementary school teachers. In K. Appleton (Ed.), *Elementary science teacher education* (pp. 31-54). Mahwah, NJ: Lawrence Erlbaum.
- Avery, L. M. (2012). Teaching science as science is practiced: Opportunities and limits for enhancing preservice elementary teachers' Self-Efficacy for science and science teaching. *School Science and Mathematics*, 112(7), 395-409. <https://doi.org/10.1111/j.1949-8594.2012.00159.x>
- Baarda, B. (2010). *Research: this is it! Guidelines for setting up, doing and evaluating quantitative and qualitative research* (1st ed). Groningen: Noordhoff.
- Butler, D. L. and Schnellert, L. (2012). Collaborative inquiry in teacher professional development. *Teaching and Teacher Education*, 28, 1206-1220. <https://doi.org/10.1016/j.tate.2012.07.009>
- Bybee, R., Taylor, J. A., Gardner, A., Scotter, P. V., Powell, J. C., Westbrook, A. and Landes, N. (2006). *The BSCS 5E Instructional Model: origins and effectiveness*. Colorado Springs, Co.
- Carlson, D., Borman, G. D. and Robinson, M. (2011). A multistate district-level cluster randomized trial of the impact of data-driven reform on reading and mathematics achievement. *Educational Evaluation and Policy Analysis*, 33(3), 378-398. <https://doi.org/10.3102/0162373711412765>
- Driver, R., Asoko, H. and Leach, J. M. S. P. (1994). The Nature of Scientific Knowledge. *Educational Researcher*, 23(7), 3.
- Filderman, M. J. and Toste, J. R. (2018). Decisions, decisions, decisions using data to make instructional decisions for struggling readers data-based decision making. *Teaching Exceptional Children*, 50(3), 130-140. <https://doi.org/10.1177/0040059917740701>



- Fitzgerald, A., Dawson, V. and Hackling, M. (2013). Examining the beliefs and practices of four effective Australian primary science teachers. *Research in Science Education*, 43(3), 981-1003. <https://doi.org/10.1007/s11165-012-9297-y>
- Fullan, M. (2001). *The meaning of educational change*. New York and London: Teacher College Press.
- Gerard, L. F., Spitulnik, M. and Linn, M. C. (2010). Teacher use of evidence to customize inquiry science instruction. *Journal of Research in Science Teaching*, 47(9), 1037-1063. <https://doi.org/10.1002/tea.20367>
- Gillies, R. M. and Nichols, K. (2014). How to support primary teachers' implementation of inquiry: teachers' reflections on teaching cooperative inquiry-based science. *Research in Science Education*, 45(2), 171-191. <https://doi.org/10.1007/s11165-014-9418-x>
- Goldston, M. J., Dantzler, J., Day, J. and Webb, B. (2013). A psychometric approach to the development of a 5E Lesson plan scoring instrument for inquiry-based teaching. *Journal of Science Teacher Education*, 24(3), 527-551. <https://doi.org/10.1007/s10972-012-9327-7>
- Hilby, A. C., Stripling, C. T. and Stephens, C. A. (2014). Exploring the disconnect between mathematics ability and mathematics efficacy among preservice agricultural education teachers. *Journal of Agricultural Education*, 55(5). <https://doi.org/10.5032/jae.2014.05111>
- Hillman, S. J., Zeeman, S. I., Tilburg, C. E. and List, H. E. (2016). My Attitudes Toward Science (MATS): the development of a multidimensional instrument measuring students' science attitudes. *Learning Environments Research*, 19(2), 203-219. <https://doi.org/10.1007/s10984-016-9205-x>
- Hodgson, C. and Pyle, K. (2010). *A literature review of Assessment for Learning in science*. Slough: Nfer. Available at: <http://citeseerx.ist.psu.edu/viewdoc/download?doi=10.1.1.471.3251&rep=rep1&type=pdf>
- Ketelaar, E., Koopman, M., Den Brok, P. J., Beijaard, D. and Boshuizen, H. P. A. (2014). Teachers learning experiences in relation to their ownership, sense-making and agency. *Teachers and Teaching: Theory and Practice*, 20(3), 314-337. <https://doi.org/10.1080/13540602.2013.848523>
- Krueger, R. A. and Casey, M. A. (2015). *Focus groups: A practical guide for applied research* (5th ed.). Singapore: Sage publications.
- Laevers, F. and Peeters, A. (1994). *De Leuvense betrokkenheidschaal voor leerlingen LBS-L: Handleiding bij de videomontage*. Leuven: Centrum voor Ervaringsgericht Onderwijs.
- Murphy, C., Murphy, C. and Kilfeather, P. (2011). Children Making Sense of Science. *Research in Science Education*, 41, 283-298. <https://doi.org/10.1007/s11165-010-9165-6>
- Murphy, C., Varley, J. and Veale, Ó. (2012). I'd rather they did experiments with us.... than just Talking: Irish children's views of primary school science. *Research in Science Education*, 42(3), 415-438. <https://doi.org/10.1007/s11165-010-9204-3>
- Onstenk, J., Kallenberg, T., Koster, B. and Scheepsmas, W. (2011). *Ontwikkeling door onderzoek*. Amersfoort: Thieme Meulenhoff.
- Osborne, J., Simon, S. and Collins, S. (2003). Attitudes towards science: A review of the literature and its implications. *International Journal of Science Education*, 25(9), 1049-1079. <https://doi.org/10.1080/0950069032000032199>
- Schildkamp, K. and Kuiper, W. (2010). Data-informed curriculum reform: Which data, what purposes, and promoting and hindering factors. *Teaching and Teacher Education*. <https://doi.org/10.1016/j.tate.2009.06.007>
- Schnellert, L. M., Butler, D. L. and Higginson, S. K. (2008). Co-constructors of data, co-constructors of meaning: Teacher professional development in an age of accountability. *Teaching and Teacher Education*, 24(3), 725-750. <https://doi.org/10.1016/j.tate.2007.04.001>
- SLO. (2017). Observatie instrument. Available at: [http://www.slo.nl/nl/voortgezet/onderbouw/themas/vormob/kern\\_keuzedeel/afstemming/bijl\\_les.doc/](http://www.slo.nl/nl/voortgezet/onderbouw/themas/vormob/kern_keuzedeel/afstemming/bijl_les.doc/) (Accessed March 3, 2018)
- Smith, G. (2013). An innovative model of professional development to enhance the teaching and learning of primary science in Irish schools. *Professional Development in Education*, 40(3), 467-487. <https://doi.org/10.1080/19415257.2013.830274>
- Van Aalderen-Smeets, S. I., Walma Van Der Molen, J. H. and Asma, L. J. F. (2012). Primary teachers' attitudes toward science: A new theoretical framework. *Science Education*, 96(1), 158-182. <https://doi.org/10.1002/sce.20467>
- Van den Hurk, H. T. G., Houtveen, a. a. M., Van de Grift, W. J. C. M. and Cras, D. W. P. (2014). Data-feedback in teacher training. Using observational data to improve student teachers' reading instruction. *Studies in Educational Evaluation*, 42, 71-78. <https://doi.org/10.1016/j.stueduc.2013.10.009>

- Van Geel, M., Keuning, T., Visscher, A. J. and Fox, J.-P. (2016). Assessing the Effects of a Schoolwide Data-Based Decision Making Intervention on Student Achievement Growth in Primary Schools. *American Educational Research Journal*, 53(2), 360-394. <https://doi.org/10.3102/0002831216637346>
- Van Veen, K., Zwart, R. and Meirink, J. (2012). What makes teacher professional development effective? A literature review. In M. Kooy and K. Veen (Eds.), *Teacher learning that matters: International perspectives*. (pp. 3-21). New York: NY: Routledge.

## Recycling Plastics: Middle School Students Create Solutions During a Summer Camp

Ergun Akleman<sup>1</sup>, Luciana Barroso<sup>2,3</sup>, Mary M. Capraro<sup>2,4\*</sup>, Terry Creasy<sup>1</sup>, Kenneth Fleming<sup>4</sup>, Weiling He<sup>1</sup>, Hong Liang<sup>3</sup>, Ashley M. Williams<sup>2,4</sup>

<sup>1</sup> Texas A&M University, College of Architecture, College Station, USA

<sup>2</sup> Texas A&M University, Aggie STEM, USA

<sup>3</sup> Texas A&M University, College of Engineering, USA

<sup>4</sup> Texas A&M University, College of Education and Human Development, USA

\*Corresponding Author: [mmcapraro@tamu.edu](mailto:mmcapraro@tamu.edu)

**Citation:** Akleman, E., Barroso, L., Capraro, M. M., Creasy, T., Fleming, K., He, W., Liang, H. and Williams, A. M. (2019). Recycling Plastics: Middle School Students Create Solutions During a Summer Camp. *European Journal of STEM Education*, 4(1), 10. <https://doi.org/10.20897/ejsteme/6341>

**Published:** December 5, 2019

### ABSTRACT

Four distinct plastics recycling projects created by middle school students emerged from a one-week long plastics recycling activity incorporated within a science, technology, engineering, and mathematics (STEM) residential summer camp at a research-intensive university. The plastics recycling activity was a project-based learning (PBL) activity facilitated by STEM experts in geometry, architecture, and materials science. Specific instruction involving mathematics and science concepts was provided to emphasize content-specific knowledge related to plastics recycling. A rubric was applied and used to determine evidence of learning manifested in participants' final presentations. Participants' final presentations demonstrated mixed results in terms of student learning outcomes, but indicated that campers demonstrated a clear sense of social environmental awareness and responsibility toward recycling plastics.

**Keywords:** recycling, STEM PBL, middle school (ages 11-14), informal learning, social environmental awareness

### INTRODUCTION

Throughout history, mankind has strived to identify innovative solutions to problems for the betterment of society. Today, the need for innovative problem solvers remains just as imperative, particularly in relation to environmental issues and recycling. Educating the next generation of problem solvers requires a critical evaluation of the learning opportunities that students have in formal and informal settings. Doing so will ensure that current and future generations are properly equipped to make informed and inspired decisions when addressing existing environmental problems, such as the growing need for effective recycling programs. Therefore, the purpose of the study was to determine if middle school students, when presented with an environmental problem and content-specific knowledge about materials science, architecture, 3-D printing, and geometry and topology, would be able to integrate this knowledge into a socially responsible solution of their own design that could address the ubiquitous problem of plastic bottle waste. In particular, we examined how rich and in-depth content knowledge in these fields combined with the true integration of science, technology, engineering, and mathematics (STEM) disciplines facilitated middle school campers' development of environmental awareness and social responsibility (Watts, 2001) during a one-week camp while working on a recycling plastics project. In the present study, we analyzed social

environmental awareness and responsibility as a single conceptual unit that refers to a mindfulness about factors that affect the world and an increasing awareness of how to correct identified environmental problems.

There have been a number examples of landmark innovations in which both the search for and identification of solutions have exercised, bridged, and expanded STEM discipline-related knowledge (Chandra and Dong, 2015). Pressing real-world challenges drove many of these integrated STEM advancements. For instance, the need to power an expanding network of mills and factories in the mid-eighteenth century, which heavily relied on coal as a fuel source, drove coal mining to new depths and created a unique problem that would ultimately lead to breakthroughs in science, technology, engineering, and mathematics. The challenge was that deeper coal mines were prone to flooding, which would halt coal production for days and weeks on end. Miners traded their pickaxes for pails and buckets as they physically carried the water up and out of the mines (Brenni, Giatti, and Barbacci, 2010). This pressing economic problem needed an informed engineering response.

Academia had already discovered some basic principles of heat, water, and steam, and during the early-eighteenth century engineers like Thomas Savery and Thomas Newcomen had developed and improved steam pumps that turned water into steam that then rose through pipes up and out of the flooded mines (Hulse, 1999). The steam pumps designed by Savery and Newcomen were inefficient however, losing much of their thermal energy with every stroke because the steam was heated and cooled within their master cylinders. James Watt, having recognized the power this source of rising steam could generate (Marsden, 2002), applied another principle of the conservation of energy to develop a separate condenser outside the master cylinder, thereby designing an efficient steam engine that stayed hot with every stroke.

Watt's steam engine functioned as a catalyst in increasing the research and production of thermal energy scholarship and led to the birth of thermodynamics. The need to improve the efficiency of heat engines led to a closer examination of the nature of how heat moves differently through different materials and the relationship between heat and work. As Watt designed the steam engine, he had opportunities to collaborate with Joseph Black, a scientist whose work included developing a more comprehensive understanding of latent heat (the heat required to change states of matter) and specific heat (the heat energy required to raise a substance's temperature a single degree) (Kerker, 1961). In the midst of these advances, innovations in the engineering of improved thermometers also made it possible to attain more precise measurements of temperature. Thus, a series of academic discoveries were interwoven with the technological innovation of the time to make discoveries to improve our society. No one field led the innovations, but rather innovations and knowledge from each facilitated the progress that occurred in the other STEM fields (Brenni et al., 2010; Kerker, 1961; Miller, 2008).

These examples of shared discovery and innovation from the past illustrate the complexity of preparing future innovators to function in an integrated STEM environment. The period of mutually-beneficial discoveries spurred by the need to solve a pressing mining problem demonstrates the intersectionality of innovation: an economic problem became the focus of an engineering problem, and the solutions devised to solve the engineering problem were informed by scientific understandings of the physics and principles of energy and matter. Scientific understandings and an engineering approach were used to develop technology to resolve the issue. The technological developments needed refinement as safety and efficiency became social and economic priorities. Engineering and technology benefited from the steam engine and its commercialization. Mathematicians and physicists benefited from a mathematical model for heat propagation. Scientists exchanged incomplete and competing concepts of heat transfer, which facilitated the development of more comprehensive theories of thermodynamics.

Today, there are recent widespread and long-lasting changes to our planet's surface due to the accumulation and fragmentation of plastics. The amount of plastic manufactured in the first ten years of this century alone has eclipsed the total amount of plastics produced in the entire twentieth century. Single-use plastic bottles are only one of many plastic products produced, but these lightweight, inexpensive bottles are long-lived, and their mass production and disposal in the garbage will continue to pose a significant problem for centuries. As with the mining challenge described before, the current compounding problem of plastic waste can serve as a meaningful opportunity for our next generation to exercise, bridge, and expand their ability to innovate in an integrated STEM context.

## **LITERATURE REVIEW**

Exposing students to true integration of the STEM subjects in real-world situations is important for ensuring that our society has equipped and well-informed problem solvers it may depend on for generations to come. Informal learning environments, such as summer camps, provide excellent conditions for implementing integrated learning through STEM project-based learning (PBL) while enhancing students' social environmental awareness and responsibility (Watts, 2001). Informal STEM activities can offer students opportunities to advance their STEM understanding and knowledge (Ihrig, Lane, Mahatmya, and Assouline, 2018; Mosse and Bottrell, 2016). In the

current study, we used a combination of educational approaches to create a rich and relevant atmosphere for STEM learning that has the potential to engage students and enhance their environmental awareness.

### **STEM Discipline Content Knowledge**

When the National Science Foundation first began to use the term “STEM”, the term simply referred to the four separate and distinct fields we know as science, technology, engineering, and/or mathematics (Sanders, 2009). However, in recent years researchers and educators have begun to use the term STEM to refer to some level of integration of the disciplines. Integrative STEM education was not intended to be a new stand-alone subject area (Sanders, 2009), but was instead intended to focus on the understanding of content from the individual disciplines and how to integrate them to solve problems. Research has shown that teaching students using a careful balance of content-specific and interdisciplinary instruction helps to advance STEM integration and enhance students’ learning within each STEM discipline (English, 2016). In addition, findings have indicated that the integration of STEM concepts and practices has the promise to lead to increased conceptual learning within the disciplines (Honey, Pearson, and Schweingruber, 2014). Improvement of students’ learning within STEM disciplines is critical as there is a global need to increase student proficiency in both science and mathematics. According to the most recent Programme for International Student assessment (PISA) reports, 20% of students across the Organization for Economic Co-operation and Development (OECD) countries perform below proficiency in science, and 23.4% of students perform below proficiency in mathematics (OECD, 2016). Given the need for improved student proficiency in mathematics and science, and the demonstrated benefits of presenting students with a balanced instruction of content-specific and integrated STEM instruction, it is important to support students in building knowledge and skills both within the four STEM disciplines and across disciplines (Honey et al., 2014). In the present study, we aim to find that balance by providing in-depth STEM content knowledge within an integrated STEM PBL recycling activity. In-depth STEM content knowledge in this context refers to the specific and comprehensive instruction involving an individual STEM concept designed to emphasize content-specific knowledge related to plastics recycling. Ultimately, maintaining the conceptual depth of each STEM discipline was the goal in providing in-depth STEM content knowledge instruction within the integrated STEM PBL recycling activity.

### **True STEM Integration**

In the Next Generation Science Standards (NGSS) and the Common Core State Standards for mathematics (CCSSM), there is a call for deeper connections among STEM subjects (National Academy of Engineering and National Research Council, 2014). Integration of STEM subjects has been shown to expose students to the connections among and across STEM concepts, supporting learning and application of concepts simultaneously rather than in isolation (Ntemngwa and Oliver, 2018). Integrated STEM instruction can be understood as interdisciplinary education that combines science, technology, engineering, and mathematics, making learning more connected and relevant for students (Stohlmann, Moore, and Roehrig, 2012). Researchers have identified a truly integrated STEM project as a project that involves collaboration toward identifying solutions to a real-world problem and that requires individuals to utilize technology to explore information; apply mathematics, engineering, and science concepts; analyze evidence; and develop conclusions (Burrows, Lockwood, Borowczak, Janak, and Barber, 2018). STEM integration can be defined as the purposeful merging of the four disciplines in order to deepen understanding by contextualizing concepts, broaden understanding through socially and culturally relevant contexts, and increase interest in STEM fields (Guzey, Harwell, and Moore, 2014). Instruction that includes STEM integration has been found to be common within college level courses; however, Becker and Park (2011) indicated that early exposure to integrated approaches may yield higher student achievement scores in STEM subjects.

STEM integrated instruction that incorporates real-world contexts and issues has been shown to increase student interest and achievement in STEM subjects, yet there is a gap in the research on how to best integrate STEM disciplines and on what factors related to the integrated instruction influenced the positive outcomes (Pearson, 2017). English (2016) found that although the integration of STEM disciplines has been advocated in the literature, studies in which researchers addressed multiple STEM disciplines are scarce, often with mixed findings, insufficient directions for STEM advancement, and varied perspectives on how discipline integration can be achieved. In addition, there is a gap in the research on what integrated STEM looks like, particularly in terms of how teachers have conceptualized and implemented integrated STEM (Srikoom, Faikhamta, and Hanuscin, 2018). Several new instructional materials, programs, and specialized schools that address one or more of the STEM subjects separately have emerged, and there have been increased calls for emphasizing connections between and among the subjects (Honey et al., 2014). It is critical for students to understand and practice meaningful integration of STEM subjects in their own learning; however, this process has often been impeded in the classroom, in which one STEM subject tends to become the primary focus of classroom activities (Burrows et al.,

2018). In the present study, we defined true integration as a process by which each STEM discipline converges in a manner that emphasizes the interconnectedness of STEM subjects while maintaining the conceptual depth of each discipline. The plastics recycling context of the current study provided students the opportunity to engage in activities that were centered around real-world problems that necessitated the true integration of STEM subjects.

### **Social Environmental Awareness and Responsibility**

Social environmental awareness and responsibility is an important characteristic to develop in children and adults in order to improve the condition of our planet and ensure a sustainable future. This term refers to one's awareness and sense of personal accountability for helping address environmental problems in the world (Watts, 2001). Research in environmental STEM education has been limited to an investigation of the effects of one-time experiences, such as field trips. As a result, there are gaps in the literature when investigating the impact of longer experiences, which is significant because the level of engagement with STEM topics and the interaction with the learning environment have different cognitive and affective impacts (Khanaposhtani, Liu, Gottesman, Shepardson, and Pijanowski, 2018). According to the Executive Office of the President (2013), the health and longevity of our nation's environmental resources depend on the acceleration of scientific and technological innovations. Environmental and societal impacts of the 21<sup>st</sup> century drive the global urgency to improve STEM education (Kelley and Knowles, 2016). Perhaps one of the most significant impacts of society in recent history is its considerable production of waste. "Most of the 150 million tons of plastics produced around the world every day end up in landfills, the oceans, and elsewhere" ("Scientific Advances," 2018: 36). Waste and its disposal present several significant environmental, social, and economic challenges, and waste recycling has become an important focus (Yeboah, Asante, and Opoku-Asare, 2016). The problems posed by plastic waste and the identification of viable solutions have presented an opportunity to connect informal STEM learning and social environmental awareness and responsibility. Within the last four years, researchers have begun to take advantage of this opportunity to engage students in STEM fields while targeting environmental awareness and increasing students' environmental knowledge (Burrows et al., 2018; Faria, Klima, Posen, and Azevedo, 2015; Hoang and Kato, 2016; Phamduy, Milne, Leou, and Porfiri, 2015). For example, Phamduy et al. (2015) used a robotic fish project to show the potential informal learning has to engage students and the public in STEM fields while fostering awareness of environmental issues. Plastics recycling is an urgent environmental and social issue whose solutions rely on an integrated STEM approach.

### **STEM PBL**

STEM project-based learning (PBL) is an instructional method in which students collaborate to solve problems and apply ideas through STEM-related activities that incorporate real-world scenarios. This instructional strategy originated from authors such as Dewey (1916) and Kilpatrick (1918) and includes practices such as engaging students through using a well-defined outcome within an ill-defined task (Capraro, Capraro, and Morgan, 2013), integrating at least two of the STEM disciplines in a PBL activity, and providing student-centered instruction with authentic, real-life topics (Cook and Weaver, 2015). The Common Core State Standards (CCSS), the Next Generation Science Standards (NGSS), the National Council of Teachers of Mathematics (NCTM) Principles and Standards for School Mathematics, and the Texas Essential Knowledge and Skills (TEKS) all contain requirements that integrate STEM topics.

The intent of establishing national standards is to assess and ensure that students are prepared to actively engage with and contribute to the world both within and outside of the classroom. Use of STEM PBL has been shown to be highly effective in helping students develop 21<sup>st</sup> century skills (Galvan and Coronado, 2014). Moreover, students have been found to be more engaged with STEM content when it is presented in the form of STEM PBL instruction that merges real-world applications and rigorous content knowledge (Craft and Capraro, 2017). Fostering social environmental awareness and responsibility and addressing environmental problems such as plastic waste are global concerns that can be used as a context to provide students with engaging learning opportunities framed around authentic, real-life topics and issues related to STEM PBL (Phamduy et al., 2015). The following research question was used to guide the present study: How does instruction designed to expand both in-depth content knowledge of specific topics in mathematics and science, and integrated STEM knowledge facilitate middle school campers' development of STEM content knowledge and their sense of social environmental awareness and responsibility while working on a recycling plastics project?

### **METHODOLOGY**

Researchers at a Research I university designed one-week residential STEM summer camps for secondary school students. During these informal STEM camps, middle school boys and girls participated in STEM project-





**Figure 1.** Campers visiting the polymer recycling lab

based, hands-on activities (PBLs), such as 3D printing and designing, aquaponics (combination of aquaculture [fish farming] and hydroponics [growing plants without soil]), app creation, bridge building, cryptography, coding, and recycling. The students engaged in PBLs for a total of 90 hours of instruction during the camps. During each of the activities, campers were required to share in discussions, create presentations, organize resources, and design products as they applied their STEM knowledge in real-life scenarios. The middle school students participated in the recycling STEM PBL activity over the course of one week. The aim of incorporating this activity in the camp was to engage the campers in the following: a) exploring the environmental problems caused to the planet's surface by the accumulation and fragmentation of plastics, b) determining how to efficiently recycle plastic bottles, c) learning how plastic is recycled, d) designing a geometrically pleasing load bearing structure with water bottles, and e) ultimately creating a unique and practical use for recycled plastics (see [Appendix A](#) for a detailed day-by-day breakdown of prior knowledge expectations, content, and learning objectives of each aspect of the camp). The campers participated in the recycling activity for 90 minutes each day of the camp under the supervision and instruction of professors and graduate students who specialize in various aspects of the STEM-related activity. The professors and graduate students who helped teach during the recycling activity were assigned to teach on specific days in which the content of the activity aligned to their area of STEM expertise (see [Appendix B](#) for a design of the instruction).

On Day 1, campers were introduced to the real-world project of solving the recycling problem and the effects of lack of recycling on our planet. In addition, they learned about the chemical building blocks that make plastics components that harm people and the environment. The following provides an overview of several key statistics and facts the campers learned. Each year, over 150,000,000 tons of plastics produced around world end up in landfills, the oceans, and elsewhere. Unfortunately, less than 9% of plastics in the world are recycled. Chemicals added to plastics are absorbed by human bodies, and plastic buried deep in landfills can leach harmful chemicals that spread into groundwater. Some of these compounds have been found to alter hormones or have other potentially negative effects on human health. Furthermore, plastic debris, laced with chemicals and often ingested by marine animals, can injure or poison wildlife. Floating plastic waste, which can survive for thousands of years in water, serves as mini transportation devices for invasive species, disrupting habitats. After being introduced to the problem and implications of plastic waste, campers were then tasked with developing an innovative product for recycling waste and were informed that the activities they would be engaging in each day of camp would build their understanding of the various sciences involved in plastics recycling. They then began their research storyboards, examining both the problem of throwing plastics into our landfills and the potential damage the various forms of waste disposal can have on the environment, including people and animals.

On Day 2, campers learned about the science behind plastics and recycling and took a tour of a laboratory on campus where plastics are recycled. During the information session, campers were also introduced to materials processing technology for thermoplastic manufacturing and recycling. Campers were familiarized with the basics of polymer science and processing/recycling information, such as what polymers can be recycled and how new and recycled polymers are molded into useful forms. During a hands-on activity, participants received polyethylene shopping bags that they cut into small, more easily melted pieces. They then visited the polymer recycling lab off campus and observed their plastic bag pieces being melted and transformed into usable polymers (see [Figure 1](#)).



Figure 2. Plastic bag before and after



Figure 3. Example of a triple torus structure

The bags they had cut up previously were placed in a convection oven and heated to the processing temperature. The instructor demonstrated how the material was soft and flowable and could be shaped. Each charge of polymer melt was placed in a manual hydraulic press and turned into thick, flat panels. The campers could observe how the printing and colors on the bags remained and moved as the polymer flowed into its new shape. Further, campers could see the thin, flexible bags become rigid and strong sheets when consolidated into thick plates (see [Figure 2](#)).

On Day 3, campers engaged in 3D geometry and mathematical topology, providing them the background knowledge needed to design 3D shapes. Topology differs from geometry in that geometrically equivalent objects often share numerically measured quantities, such as lengths or angles, while topologically equivalent objects resemble each other in a more qualitative sense. More specifically, topology is a branch of mathematics in which two objects are considered equivalent if they can be continuously deformed into one another through such motions in space as bending, twisting, stretching, and shrinking while disallowing the tearing apart or gluing together of parts. The main idea of such topological construction comes from the fact that any surface can be decomposed using vertices. During the 3D printing component of the recycling activity, the instructor introduced both geometric and topological concepts and associated terminology. Terminology introduced during the activity included terms such as face, edges, base, congruent, intersection, solid, parallel, perpendicular, vertices, and planes. The instructor demonstrated geometrical and topological concepts. Students experimented with folding and cutting paper to apply the properties of geometric and topological shapes. To engage the students in tactile learning, the instructor had the students create various large shapes using the plastic bottles and connectors while applying geometric and topological concepts (see [Figure 4](#)). Students then used the 3-D printed bottle connectors to build 3-dimensional shapes using plastic bottles. The campers then had to apply the concepts and hands-on experience acquired to develop their final model structure. The students used this final model structure to present their unique and practical use for recycled plastics.

On Day 4, campers worked on presentations of their possible unique and practical product use for recycled plastics, which they could later construct from recycled plastics that they designed and printed in their 3-D printing



**Figure 4.** Campers using connectors and bottles to design a 3D shape

class. On the fifth and last day, campers presented a mock sales presentation to a group of hypothetical investors comprised of their peers and instructors. These investors could choose to fund or invest in the campers' product, which the campers could make in the future from recycled plastic filament.

A rubric was used to assess the campers' design, presentation, and marketing of their recycled product. This summative presentation rubric contained five criteria: demonstrated in-depth content knowledge in at least two STEM areas, integrated STEM knowledge, originality, engineering design process, and recycling knowledge. The "recycling knowledge" criterion measured each camper's sense of social environmental awareness and responsibility, which was assessed as both a cognitive and an action factor. As a cognitive factor, campers were assessed on their demonstrated capabilities to recognize the social and environmental issues of plastic use (Lauwrens, 2019; Sullivan, 2019; Watts, 2001). As an action factor, campers were assessed on their demonstrated capabilities to actively seek solutions to a problem or modify their own behaviors in response to the newly acquired knowledge (Gupta and Sinha, 2001). The other two criteria relevant to the current paper were "demonstrated in-depth content knowledge in at least two STEM areas" and "integrated STEM knowledge." These criteria were used to determine if campers were adequate in their application of the *integration* of STEM disciplinary knowledge and their ability to articulate the integration of in-depth knowledge in at least two STEM subjects during the presentation of their unique product. The first of these will be discussed later in the paper.

The criterion "integrated STEM knowledge" had a rating scale of 4 along with the concrete indicators or descriptors. After engaging in the camp's informal learning activities while developing their product and preparing their presentation, we expected students to at least talk about the **S**cience of recycling, the **T**echnology of using the 3D printer; the **E**ngineering design process involved in their product development, and the **M**athematical geometry of measuring. To receive a 4, the indicator required that a student needed to demonstrate how they integrated their knowledge of the STEM topics in developing their recycled product and their argument was fully developed and supported; a 3 indicated they adequately developed their recycled product using their knowledge of integrating STEM topics and their argument was adequately supported and occasionally repetitive; a 2 was given when students partially developed a limited understanding of integrating STEM topics as they described their recycled product and their presentation was repetitive; a 1 indicated a very limited and basic understanding of how they integrated the STEM topics with a minimally developed and supported recycled product and presentation.

## Participants

This pilot study was conducted with middle school students during a one-week residential STEM summer camp that took place in south-central Texas during the summer of 2018. A total of 315 campers participated in the camp; however, only 9 middle school campers (2 females and 7 males) enrolled in the summer camp that included the plastic recycling PBL activity that was the focus of the present study. These campers were entering grades 7 through 9 during the upcoming academic year and were primarily from Texas cities, although several participants were from other states across the U.S. The ethnic demographics for all the campers ( $n = 315$ ) were the following: White (55%), Hispanic (23%), Asian (7%), Black (6%), Indian (2%), or N/A (8%), indicating no specific ethnicity.

## RESULTS

The purpose of this study was to answer the following: How does instruction designed to expand both in-depth content knowledge in mathematics and science and integrated STEM knowledge facilitate middle school campers' development of STEM content knowledge and their sense of social environmental awareness and responsibility while working on a recycling plastics project? All week, campers worked on a proposal to hypothetical investors. Campers were tasked to create a proposal for a recycling product that would help to address the issue of plastic waste and pollution resulting from everyday plastic use. In order to emphasize the STEM aspects in learning, one constraint was that the campers could not make an art project.<sup>1</sup> Campers were provided the design challenge on the first day of camp to allow them to intentionally seek STEM knowledge and to think about the practical application of that knowledge while going through content-specific activities in each of the topics described above. Additionally, campers were expected to design a product (engineering) in conjunction with the 3-D printing class (technology) they were dual enrolled in. The engineering design process was included in another class they took during the week. In our recycling class, the science of recycling and the mathematics necessary to effectively design a product from recycled plastics (social environmental awareness and responsibility) were the focus. Thus, all four STEM topics were included in the learning process.

The nine participating campers were allowed to work individually or in self-selected groups to produce a final recycling product and presentation. Two of the campers worked individually on their own projects and seven campers chose to work in two separate groups. This process resulted in four total presentations, three of which were interactive PowerPoint presentations and one of which was a 24 by 36-inch presentation storyboard. Each of the campers appeared enthusiastic about the project. They started their presentations by articulating the environmental damages that non-recycled plastics cause. Their voices and body language suggested an intense level of involvement in the project. However, the actual design of the projects they created did not demonstrate an in-depth level of STEM knowledge reflective of the activities they were engaged in during the camp.

The research team independently rated the summative presentations on a 5-point scale as to whether the, "student demonstrated in-depth content knowledge in at least two STEM areas." To achieve a score of "5," students would have had to demonstrate an in-depth level of knowledge in two or more STEM disciplines. This required evidence during a student's presentation that they engaged with and understood the complexities of the subjects they studied during camp. An example of this would be a discussion of the chemical structure of common plastics (science) and how the student utilized the engineering design process to make design decisions in the presence of constraints (engineering) for their unique product based on this knowledge. Unfortunately, none of the students demonstrated an in-depth level of content knowledge in two or more STEM disciplines during their presentations. Seven of the students received a "2" on this indicator, while two received a "1" on this indicator. Scores below a "3" indicated that students did not incorporate the concepts and terminology taught during the activities into their culminating presentation. Interrater reliability was not calculated due to the small sample size.

In one project, called *Nasco Plastic Reduction*, the participants proposed a rudimentary business idea with three steps: 1) investing in existing plastic reduction activities, such as individuals, programs, and volunteers; 2) investing in toys and arts that are made through the use of plastic recycling; and 3) setting up a network for interested helpers. At the beginning of step 1, the camper listed "setting up trust", although it should have been an independent step. The proposal did not involve the design of a physical product but instead the design of a marketing strategy, which indicated the campers realized the connection between STEM-based ideas and the outreach to the society through economic means.

In a second project, entitled *Recycled Garden*, the camper proposed designing gardening devices that use common plastic objects such as pots to hold plants. The camper downloaded images from the internet as a proof of the concept but did not have time to come up with an original design (see [Figure 5](#)). There was no detailed explanation about materials needed, water saturation, temperature, or irrigation. The participant attempted to emphasize the fun factor of the project, which may be how he or she thought the project could be successful (see [Figure 6](#)). Although the participant did not articulate in detail what aspects of this product and its creation are fun, the fun factor appears to be critical in young participants' value system. It is worth an in-depth investigation in our future research.

The project *AquaPure* stood out as it was the most detailed example among all of the proposals in terms of the participants examining and designing the mechanism of a device (see [Figure 7](#)). Two participants collaborated on this project. They proposed a water filtration system that used plastic water bottles as a container of filtration agents including sand, rocks, and cotton. The campers used the plastic bottles upside down and utilized the narrowing area of the original bottle opening as a funnel. One may argue that the campers' selection of images of layered filtration agents and their use of the upside down positioned plastic bottle demonstrated their intuitive

---

<sup>1</sup> Although STEM and art intersect, the complexity of art can easily direct the participating campers to focus on expressing feelings instead of identifying problems and finding solutions.





Figure 5. Campers recycled garden design concept presentation



Figure 6. The fun factor of the recycled garden design concept presentation

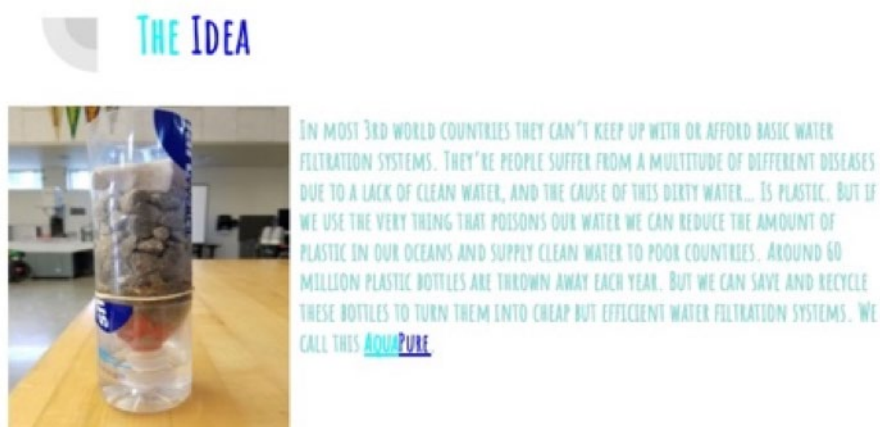

Figure 7. AquaPure project presentation

grasp of the engineering of filtration. However, the campers did not truly engineer their own filtration system. Further, this project revealed the campers' lack of knowledge about plastic bottles' toxicity. Chemicals in plastics can be unstable under the sunlight and after a period of use. Reusing these bottles to filtrate drinking water may pose a question of water and food safety.

The final project, a *Museum Information Storyboard*, was created as a museum display to inform visitors about the recycling process, including the ramifications of the damage lack of recycling causes. The storyboard incorporated an introduction of the rationale of plastic recycling, which demonstrated the camper's strong sense of social environmental awareness and responsibility. The camper also incorporated a copy of an image found online from

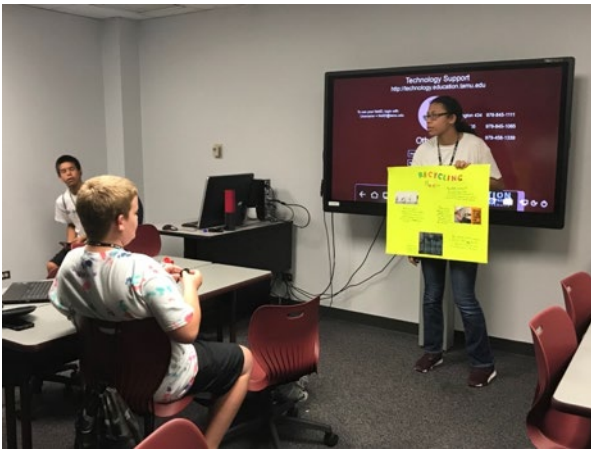

Figure 8. Camper presenting museum information storyboard

a plastic recycling DIY website ([www.preciousplastic.com](http://www.preciousplastic.com)) on his storyboard. The image presents an outline of how a recycling system can be fabricated with off-the-shelf components. In fact, this recycling system has been used by Dave Hakkens, the founder of *Precious Plastic* in collaboration with people who live in under-developed areas. The camper's storyboard also included a design of how museum visitors could bring their plastic bottles to the museum, place the bottles in a machine, and get tokens made from the plastic bottles to use for access to museum activities in exchange for recycling their plastics. The design idea was promising in terms of engaging museum visitors although its representation in the camper's presentation was limited (see Figure 8); the camper provided a single image from the internet and no more than one sentence of description regarding the design of the machine.

## DISCUSSION

The results observed in the participants' final presentations indicated mixed learning outcomes. While some of the group projects seemed to indicate that the students might have marginally increased their content knowledge, most of the projects lacked a clear application of in-depth STEM content knowledge. For instance, the camper who created the museum information storyboard provided an outline of how off-the-shelf components could be used to fabricate a recycling system. We could perhaps assume that the camper required some degree of knowledge about the process detailed in the outline in order to present the outline to his peers; however, the camper had found the outline on the internet and merely made a copy to include on his museum storyboard. Therefore, when examining this particular camper's presentation, it is difficult to determine the extent of in-depth STEM knowledge the camper acquired.

The nature of the results from the other group projects posed a similar problem. For instance, the *Nasco Plastics Reduction* group did not design a product, the camper who created the *Recycled Garden* product did not provide detailed explanation about materials needed, water saturation, temperature, or irrigation, and the *AquaPure* group lacked knowledge about plastic bottles' toxicity. Several factors may have attributed to the lack of demonstrated in-depth and integrated STEM knowledge in these projects. Time constraints and the nature of the project guidelines could have significantly influenced the campers' final products and presentations. Further development of the guidelines for the final presentations and products could better ensure that students apply the knowledge and concepts they were taught during the recycling class when designing their final products and presentations. In addition, engaging students in the plastics recycling project for a longer period may provide them with a more sufficient timeframe in which to acquire and solidify their in-depth and integrated STEM knowledge. Furthermore, increasing the duration of the plastics recycling project would provide students with additional time to design their final product and presentation as well. Further research is required to determine clearly how engaging in a plastic recycling activity influences both students' in-depth content knowledge and integrative STEM knowledge.

Although campers did not demonstrate clear improvement in their integrated and in-depth STEM content knowledge, they did display a sense of social environmental awareness and responsibility while presenting their product or strategy for reducing plastic waste. In fact, most of the student groups introduced their projects in the context of plastic pollution and presented their STEM projects as a solution to the recycling problem. Most students also discussed their future intended behavior, including a willingness to continue and/or modify their current practices in order to reduce plastic pollution. Through these actions, students clearly demonstrated their social and environmental awareness. This awareness was most evident in the *Nasco Plastic Reduction* groups' marketing strategy, which demonstrated that the campers understood the connection between STEM-based ideas



and outreach to the society. All participants stressed and understood the importance of recycling in mitigating the amount of waste produced and in ensuring a sustainable future.

When reflecting on the conclusions of the present study it is important to recognize the unique opportunity informal learning offers educators and administrators. At the time of this publication, K-12 public school systems have no uniformly or commonly recognized model of STEM integration (e.g., Bybee, 2013; Ring-Whalen, Dare, Roehrig, Titu, and Crotty, 2018). Informal settings are able to function in tandem with or outside the structure of high-stakes assessments and can therefore be a suitable test bed for STEM integration strategies prior to their implementation in a highly structured formal learning context. The present study can be used in such a way.

Through this pilot program, the researchers identified effective instructional components within the intervention as well as several limitations and challenges, all of which will be used to guide and refine the recycling plastics intervention in future studies. One particular challenge highlighted in the present study is the difficulty in isolating and emphasizing engineering principles and design within the time frame and grade level of the campers. Engineering is the design, or creation, of objects and systems that do not occur naturally to enhance the current state of the world. However, this does not happen by blind trial and error. Design decisions are to be thoughtfully made using engineering principles and tested using multiple models, from mathematical to physical prototypes, so that the end product responds in a predictable and desirable fashion under a range of conditions. Engineering principles include the ideas, rules, or concepts that must be considered during the design process. These are problem and context specific, so no single list applies. Therefore, an engineer must learn to develop models that capture the critical behaviors needed to make design decisions and predict system response. Guiding students through this process is critical to help them understand the various principles of engineering and engineering design. Although the basic components of an engineering design cycle were present in the campers' learning processes in the recycling activity, the time in which to teach students about this information was limited, as was the time available for students to apply the engineering principles in designing their final recycling product.

Therefore, we aim to evaluate the strengths and limitations of the recycling activity to determine how best to modify the activity and thereby optimize students' learning experience. Our current project was limited in results due to the length of the one-week camp even though we were able to work cooperatively with the engineering design activity and the 3D printing instructors. The informal setting provides some affordances that might not be present in a formal setting, though there are also serious constraints. The informal setting removes stress on students and faculty to master specific learning objectives within a certain timeframe and it provides the opportunity for learning in a more relaxed environment. However, the lack of pressure may also contribute to a lack of motivation to fully commit to the learning tasks. In a formal school setting, teachers of science, technology, engineering, and mathematics can work cooperatively to plan and enact the project together over a two-week period to allow the interdisciplinary nature of the project to be fully implemented. This would minimize the stress to compress time for mastering specific objectives while providing some authentic learning experiences. However, being situated within a formal setting, students who are extrinsically motivated would be more sufficiently focused on ensuring they are learning the content and working conscientiously to complete the task.

A key component for our future research will be how to introduce the rigor of system modeling and design choices into the process without stifling student creativity and enthusiasm. Every system has key behaviors; for example, a long and slender beam is governed by how it bends, and a column is governed by axial compressions. However, a column also has bending, and a beam has axial compressions. They both may have shear (cutting forces) and torsion (twisting forces). A key part of the engineer design process is identifying what those key behaviors are in order to continue into the process of how to build a model that captures them and how to analyze and design. The identification of the key behaviors for the campers' system must be part of that process. Enhancing the campers' understanding of these key components of the engineering design cycle will be of critical importance in the continuation of this research.

Nonetheless, there are a number of insights that can be gleaned from the present study. It is inherently challenging to formally assess students who are voluntarily participating in an informal STEM Camp. In fact, formal assessments may run counter to a student's agenda for participating and may mitigate motivation at some level. Even performance-based assessments are complicated by the fact that students may leave out crucial elements of their STEM learning process when presenting their ideas, making students' extent of in-depth STEM knowledge difficult to determine. This would include discussion of and rationale for the planning and redesign phases and drawn designs and how these may have evolved and changed. Future studies should investigate how to balance assessments and motivation in STEM learning. Additionally, participation in the informal STEM camp is limited to a single week; measuring long-term learning benefits may also be a limitation of this present study.

Learning to discuss and present one's own learning process and being able to explain how it occurs are important skills and part of the progression of learning to be meta-cognitive and to reflect meta-cognitively. Finally, teachers should build the skills necessary to teach students to present their learning, while schools should invest in

helping teachers become adept at PBL instructional methods and set aside funding to support student attendance of informal summer programs, where leaning can be more focused on big ideas.

## REFERENCES

- Becker, K. and Park, K. (2011). Effects of integrative approaches among science, technology, engineering, and mathematics (STEM) subjects on students' learning: A preliminary meta-analysis. *Journal of STEM Education: Innovations & Research*, 12, 23-37.
- Brenni, P., Giatti, A. and Barbacci, S. (2010). Case study 2: Steam, work, energy. Available at: <http://hipstwiki.wikifoundry.com/page/Case+Study+2>
- Burrows, A., Lockwood, M., Borowczak, M., Janak, E. and Barber, B. (2018). Integrated STEM: Focus on informal education and community collaboration through engineering. *Education Sciences*, 8, 1-15. <https://doi.org/10.3390/educsci8010004>
- Bybee, R. W. (2013). *The case for STEM education: Challenges and opportunities*. Arlington, VA: NSTA Press.
- Capraro, R. M., Capraro, M. M. and Morgan, J. (Eds.). (2013). *STEM Project-based learning: An integrated science, technology, engineering, and mathematics (STEM) approach* (2nd Ed.). Rotterdam, The Netherlands: Sense.
- Chandra, P. and Dong, A. (2015). Knowledge accumulation and the value of inventions. *Proceedings of the 2015 Portland International Conference on Management of Engineering and Technology (PICMET)*, 2187-2194. <https://doi.org/10.1109/PICMET.2015.7273056>
- Cook, N. D. and Weaver, G. G. (2015). Teachers' implementation of project-based learning: Lessons from the research goes to school programs. *Electronic Journal of Science Education*, 19(6), 1-45.
- Craft, A. and Capraro, R. M. (2017). Science, technology, engineering, and mathematics project-based learning: Merging rigor and relevance to increase student engagement. *Electronic International Journal of Education, Arts, and Science*, 3, 140-158.
- Dewey, J. (1916). *Democracy and education*. New York, NY: Macmillan.
- English, L. D. (2016). STEM education K-12: Perspectives on integration. *International Journal of STEM Education*, 3, 1-8. <https://doi.org/10.1186/s40594-016-0036-1>
- Executive Office of the President, National Science and Technology Council, Committee on STEM Education. (2013). *Federal Science, Technology, Engineering, and Mathematics (STEM) Education: 5-Year Strategic Plan*. Available at: <http://ezproxy.library.tamu.edu/login?url=http://search.ebscohost.com/login.aspx?direct=true&db=eric&AN=ED570924&site=eds-live>
- Faria, F., Klima, K., Posen, I. D. and Azevedo, I. M. L. (2015). A new approach of science, technology, engineering, and mathematics outreach in climate change, energy, and environmental decision making. *Sustainability: The Journal of Record*, 8, 261-271. <https://doi.org/10.1089/SUS.2015.29023>
- Galvan, M. E. and Coronado, J. M. (2014). Problem-based and project-based learning: Promoting differentiated instruction. *Nation Teacher Education Journal*, 7(4), 39-42.
- Gupta, A. K. and Sinha, R. (2001). Environmental conservation: Ethical concerns. In N. J. Smelser & P.B. Baltes (Eds.), *International encyclopedia of the social & behavioral sciences* (pp. 4602-4607). London, UK: Elsevier. <https://doi.org/10.1016/B0-08-043076-7/04178-4>
- Guzey, S. S., Harwell, M. and Moore, T. (2014). Development of an instrument to assess attitudes toward science, technology, engineering, and mathematics (STEM). *School Science and Mathematics*, 114, 271-279. <https://doi.org/10.1111/ssm.12077>
- Hoang, T. T. P. and Kato, T. (2016). Measuring the effect of environmental education for sustainable development at elementary schools: A case study in Da Nang city, Vietnam. *Sustainable Environment Research*, 26, 274-286. <https://doi.org/10.1016/j.serj.2016.08.005>
- Honey, M., Pearson, G. and Schweingruber, H. A. (2014). *STEM integration in K-12 education: Status, prospects, and an agenda for research*. Washington, DC: The National Academies Press.
- Hulse, D. K. (1999). *The early development of the steam engine*. Leamington Spa, UK: TEE Publishing.
- Ihrig, L. M., Lane, E., Mahatmya, D. and Assouline, S. G. (2018). STEM excellence and leadership program: Increasing the level of STEM challenge and engagement for high-achieving students in economically disadvantaged rural communities. *Journal for the Education of the Gifted*, 41, 24-42. <https://doi.org/10.1177/0162353217745158>
- Kelley, T. R. and Knowles, J. G. (2016). A conceptual framework for integrated STEM education. *International Journal of STEM Education*, 3, 1-11. <https://doi.org/10.1186/s40594-016-0046-z>
- Kerker, M. (1961). Science and the steam engine. *Technology and Culture*, 2, 381-390. <https://doi.org/10.2307/3100893>

- Khanaposhtani, M. G., Liu, C. J., Gottesman, B. L., Shepardson, D. and Pijanowski, B. (2018). Evidence that an informal environmental summer camp can contribute to the construction of the conceptual understanding and situational interest of STEM in middle-school youth. *International Journal of Science Education, Part B: Communication and Public Engagement*, 8, 227-249. <https://doi.org/10.1080/21548455.2018.1451665>
- Kilpatrick, W. H. (1918). The project method. *Teachers College Record*, 19, 319-335.
- Lauwrens, M. (2019). *How to cultivate environmental awareness in schools*. Available at: <https://www.gviusa.com/blog/how-to-cultivate-environmental-awareness-in-schools/>
- Marsden, B. (2002). *Watt's perfect engine*. New York, NY: Columbia University Press.
- Miller, D. P. (2008). Seeing the chemical steam through the historical fog: Watt's steam engine as chemistry. *Annals of Science*, 65, 47-72. <https://doi.org/10.1080/00033790701503127>
- Mosse, J. and Bottrell, C. (2016). The importance of place in evaluation of STEM partnerships between Universities and Schools in rural, remote and regional Australia. *Australasian Journal of University-Community Engagement*, 10(2), 19-43.
- National Academy of Engineering and National Research Council. (2014). *STEM integration in K-12 education: Status, prospects, and an agenda for research*. Washington, DC: The National Academies Press.
- Ntemngwa, C. and Oliver, J. S. (2018). The implementation of integrated science, technology, engineering, and mathematics (STEM) instruction using robotics in the middle school science classroom. *International Journal of Education in Mathematics, Science, and Technology*, 6, 12-40. <https://doi.org/10.18404/ijemst.380617>
- OECD (2016). *PISA 2015 results (Volume I): Excellence and equity in education*. Paris, France: OECD Publishing.
- Pearson, G. (2017). National academies piece on integrated STEM. *The Journal of Educational Research*, 110, 224-226. <https://doi.org/10.1080/00220671.2017.1289781>
- Phamduy, P., Milne, C., Leou, M. and Porfiri, M. (2015). Interactive robotic fish: A tool for informal science learning and environmental awareness. *IEEE Robotics & Automation Magazine*, 22(4), 90-95. <https://doi.org/10.1109/MRA.2015.2443991>
- Ring-Whalen, E., Dare, E., Roehrig, G., Titu, P. and Crotty, E. (2018). From conception to curricula: The role of science, technology, engineering, and mathematics in integrated STEM units. *International Journal of Education in Mathematics, Science, and Technology*, 6, 343-362. <https://doi.org/10.18404/ijemst.440338>
- Sanders, M. (2009). STEM, STEM education, STEMmania. *Technology Teacher*, 68(4), 20-26.
- Scientific advances can make it easier to recycle plastics. (2018, March). *DEM: Engineering & Manufacturing*, p. 36.
- Srikoom, W., Faikhamta, C. and Hanuscin, D. L. (2018). Dimensions of effective STEM integrated teaching practice. *K-12 STEM Education*, 4, 313-330.
- Stohlmann, M., Moore, T. J. and Roehrig, G. H. (2012). Considerations for teaching integrated STEM education. *Journal of Pre-College Engineering Education Research*, 2(1), 28-34. <https://doi.org/10.5703/1288284314653>
- Sullivan, N. (2019). *Environmental awareness: Definition, history & importance video*. Available at: <https://study.com/academy/lesson/environmental-awareness-definition-history-importance.html>
- Watts, D. G. (2001). *Environmental studies*. New York, NY: Routeledge.
- Yeboah, R., Asante, E. A. and Opoku-Asare, N. (2016). Teaching interactive art lessons with recycled waste materials as instructional resources. *Journal of Education and Practice*, 7(14), 38-59.

**APPENDIX A**

	<b>Anticipated Prior Knowledge</b>	<b>Disciplinary Experience/ Context</b>	<b>Targeted Learning Outcomes</b>		<b>Evidence of Learning in Product</b>
			<b>Cognitive Outcomes</b>	<b>Affective Outcomes</b>	
Day 1	Recognize everyday uses of plastics. Recognize that certain types of paper, plastic, metal, and glass are recyclable.	Overview of the plastics problem. Discuss the chemistry of plastic and dangers of plastic waste. Discuss the Engineering Design Process.	Describe the main points of the plastics problem, including the nature of plastic, the role of humans, and the importance of recycling. Identify the steps of the Engineering Design Process.	Recognize and value the urgency and relevance of the plastics problem. Identify one’s role and responsibility to be a part of the solution to the plastics problem.	As students begin brainstorming solutions, there should be evidence of the impact of plastic waste on landfills and living organisms in their research storyboard.
Day 2	Describe, measure, and test common physical and chemical properties of matter. Although the word polymer may not be familiar, students should be able to recognize shared traits of objects made with polymers.	Explore the field of polymer science and its relation to plastics and recycling. Explore polymers and thermoplastics during a plastics recycling lab tour.	Observe and describe which physical properties changed and which remained unchanged during the plastic recycling process. Describe what a polymer is and identify examples of common polymers.	Recognize and value the time, energy, and resources it takes to transform plastic waste into a new product.	As students continue to develop and refine their proposed solution to the plastics problem, there should be evidence of opportunities to repurpose polymers from plastic bags into new plastic molds in their research storyboard.
Day 3	Name and describe features of common 3D shapes. Be familiar with filament-based 3D printing tools.	Explore geometry & topology through hands-on model building. Fold and transform paper and construct geometric shapes with plastic bottles and connectors.	Make connections between recycled plastic polymers and the filament used in 3D printing. Build and describe 3D shapes by their shared features.	Recognize and value the complexity of topology as it relates to product design. Identify alternative uses for repurposing materials.	As students continue to refine their proposed solution, their design should include evidence of the use of more complex shapes and topologies to mirror their experiences with compounding structures.
Day 4	Be familiar with the Engineering Design Process. Be familiar with making a persuasive argument to a target audience.	Use the Engineering Design Process to develop a prototype solution to the plastics problem. Create a proposal presentation for a mock investor panel.	Apply the Engineering Design Process to develop a solution. Work collaboratively with peers. Use scientifically and mathematically correct terminology.	Recognize and value the challenge of integrating ideas from different disciplines (STEM) into comprehensive solutions to real- world problems.	As students finalize their proposed solution, there should be evidence of specific science, technology, engineering, or mathematics concepts and their layered application in their research storyboard.
Day 5	Know the protocols associated with presenting to an audience.	Present proposed solution to a panel of mock investors. Provide constructive feedback to peers.	Demonstrate specific disciplinary knowledge in at least two areas of STEM. Demonstrate ability to integrate STEM ideas into a novel solution.	Demonstrate social environmental awareness and responsibility. Demonstrate originality in proposed plastics recycling solution.	Students should demonstrate in-depth content knowledge in at least two STEM areas, integrated STEM knowledge, originality, use of the engineering design process, and application of their disposition towards recycling.

APPENDIX B

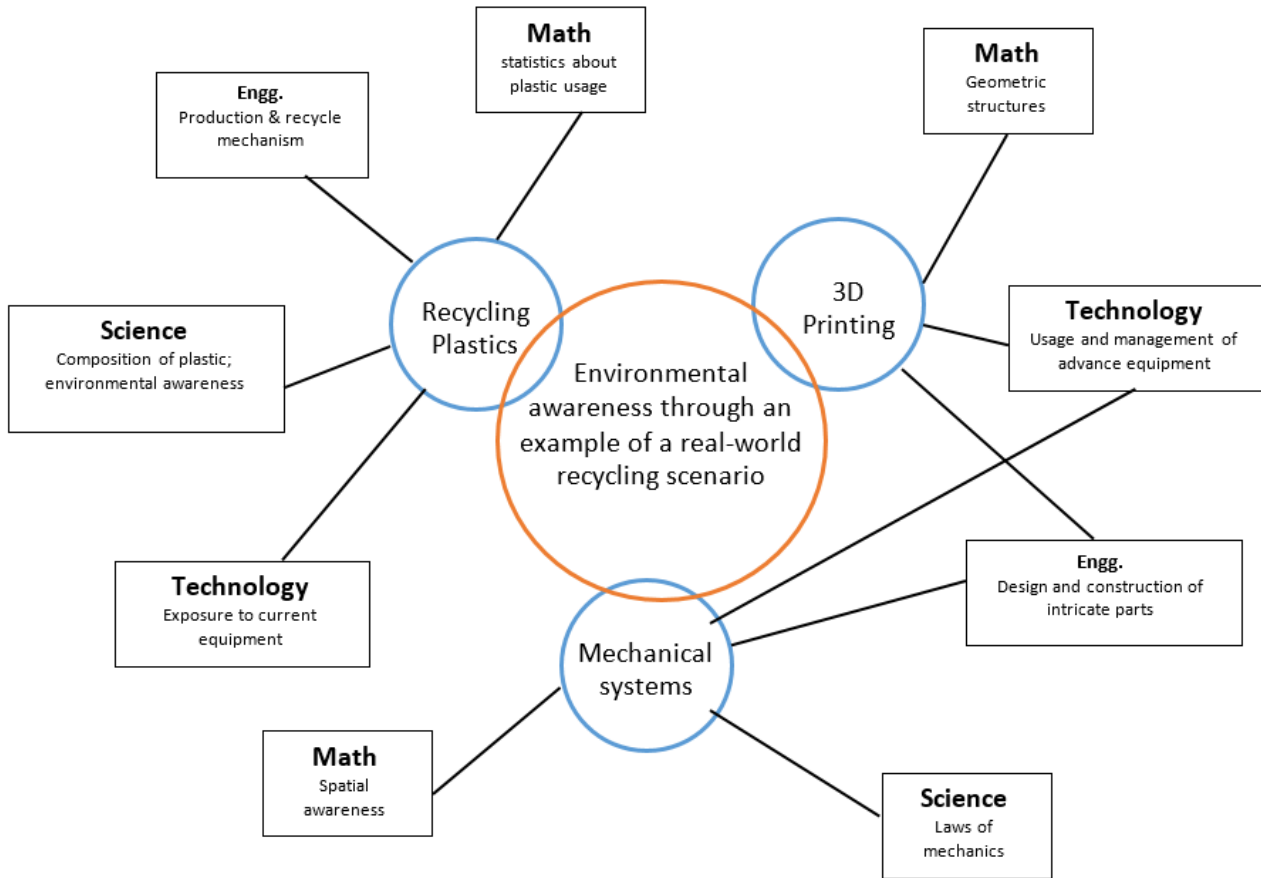



<http://www.lectitopublishing.nl>



<https://www.facebook.com/LectitoJournals/>



<https://twitter.com/lectito1>



<https://www.linkedin.com/in/lectito-journals-9a675010b/>



*This page intentionally left blank.*

<https://www.lectitopublishing.nl>